



**STRONG PARTNERS.
TOUGH TRUCKS.™**



PLATFORM PALLET TRUCK

AP2.0MS

2 000 KG



AP2.0MS - MECHANICAL SPECIFICATIONS

CHARACTERISTICS	MANUFACTURER	HYSTER								
	Model designation	AP2.0MS								
	Wheelbase type	Single Load Wheels			Tandem Load Wheels					
	Fork length mm	1125			1173			1171		
Outside fork width mm	520	560	570	520	560	670	520	560	670	

DIMENSIONS	1.3	Power: battery, diesel, LPG, electric mains	Battery	Battery	Battery
	1.4	Operation: manual, pedestrian, stand, seat, orderpicker	Pedestrian/Stand	Pedestrian/Stand	Pedestrian/Stand
	1.5	Load capacity Q (kg)	2000	2000	2000
	1.6	Load centre c (mm)	600	600	600
	1.7	Load distance, centre of drive axle to fork x (mm)	893	942	896
	1.8	Wheelbase y (mm)	1303	1352	1304

WEIGHTS	2.1	Unladen weight (with battery) kg	728	730	730
---------	-----	----------------------------------	-----	-----	-----

WHEELS & TYRES	3.1	Tyres: rubber, polyurethane, Vulkollan front/rear	Poly/Poly	Poly/Poly	Poly/Poly		
	3.2	Tyre size, front	Ø 230x75	Ø 230x75	Ø 230x75		
	3.3	Tyre size, rear	Ø 85x110	Ø 85x110	Ø 85x110		
	3.4	Additional wheels (dimensions)	Ø 125x50	Ø 125x50	Ø 125x50		
	3.5	Wheels, number front/rear (x = driven)	1X + 2/2	1X + 2/2	1X + 2/4		
	3.6	Track width, front b ₁₀ (mm)	473	473	473		
	3.7	Track width, rear b ₁₁ (mm)	350	390	500	350	390

DIMENSIONS	4.15	Lowered height h ₁₃ (mm)	83	83	83
	4.19	Overall length (Pedestrian/Stand) l ₁ (mm)	1796/2241	1844/2289	1842/2287
	4.2	Length to face of forks (Pedestrian/Stand) l ₂ (mm)	671/1116	671/1116	671/1116
	4.21	Overall width b ₁ /b ₂ (mm)	712	712	712
	4.22	Fork dimensions s/e/l (mm)	64 170 1125	64 170 1173	64 170 1171
	4.25	Outside fork width b ^s (mm)	520 560 670	520 560 670	520 560 670
	4.32	Ground clearance centre of wheelbase m ₂ (mm)	21	21	21
	4.33	Aisle width with pallets 1000mm x 1200mm wide (Pedestrian/Stand) Ast (mm)	1879/2317	N/A	N/A
	4.34	Aisle width with pallets 800mm x 1200mm long (Pedestrian/Stand) Ast (mm)	N/A	2077/2515	2079/2517
	4.35	Turning radius (Pedestrian/Stand) W ₃ (mm)	1572/2010	1619/2057	1572/2010
	4.4	Lift height h ₃ (mm)	130	130	130
4.9	Height of tiller arm in drive position min/max h ₁₄ (mm)	1219 1459	1219 1459	1219 1459	

PERFORMANCE	5.1	Travel speed with/without load (Pedestrian/Stand) km/h	6/6	8/8	6/6	8/8	6/6	8/8
	5.2	Lift speed with/without load m/s	0.04	0.05	0.04	0.05	0.04	0.05
	5.3	Lowering speed with/without load m/s	0.09	0.04	0.09	0.04	0.09	0.04
	5.8	Max gradeability with/without load %	14.5	20	14.5	20	14.5	20
	5.10	Service brake	Electric		Electric		Electric	

MOTOR	6.1	Drive motor, S2 60 minute rating kW	1.4	1.4	1.4
	6.2	Lifting motor, S3 15% rating kW	1.2	1.2	1.2
	6.3	Battery DIN 43531/35/36 A, B, C, no	B	B	B
	6.4	Battery voltage/capacity at 5 hour rate V/Ah	24/230 24/330	24/230 24/330	24/230 24/330
	6.5	Battery weight +/-5% kg	212/288	212/288	212/288
	6.6	Energy consumption according to VDI cycle kWh/h	0.43	0.43	0.43

OTHER	8.1	Drive control	AC	AC	AC
	8.4	Sound level at the driver's ear according to DIN 12 053 dB(A)	<70	<70	<70

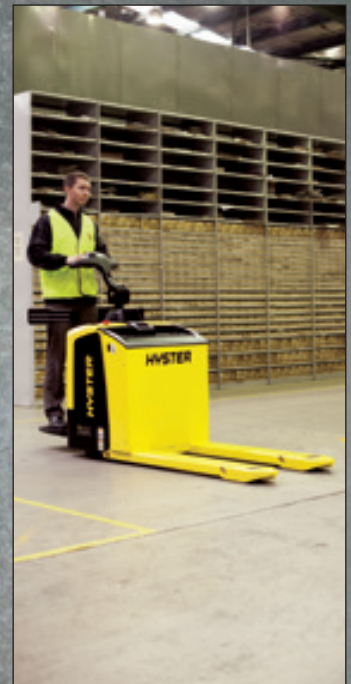
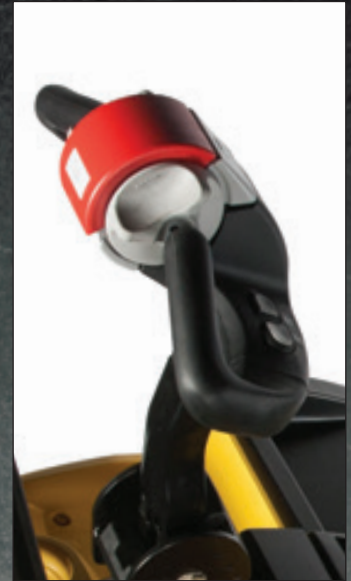

AP2.OMS - STANDARD FEATURES & OPTIONS

STANDARD FEATURES

- Battery Compartment 218mm
- Battery Size LxWxH (212x624x627)
- 24 Volt
- AC Traction Control
- Single Load Wheels
- 1125mm Long Forks (Australia only)
- 1173mm Long Forks
- 670mm Fork Spread
- Lift Motor Time-Out at Full Height
- Operating Temperatures: 0 to 49°C
- Flush Pallet Stop
- Electromagnetic Park Brake with Service Override
- Regenerative Braking
- Mold-On Polyurethane Drive Tyre (Ø 230x75)
- Adjustable Casters (Ø 125x40)
- Impact-Resistant, Ergonomically Designed, Mid-Mount Control Handle with Cushioned Return Spring
- Direction Reversing Switch
- Creep Speed "Turtle" Button
- Three User Selectable Performance Modes
- Hour Meter and Battery Discharge Indicator with Lift Interrupt

OPTIONAL FEATURES

- Tandem Load Wheels with 1171mm Fork Lengths
- Fork Spread
- 520mm Fork Spread
- 560mm Fork Spread
- Vulkollan Load Wheel
- Load Backrest
- 1219mm H
- 1524mm H
- Battery Compartment 290mm

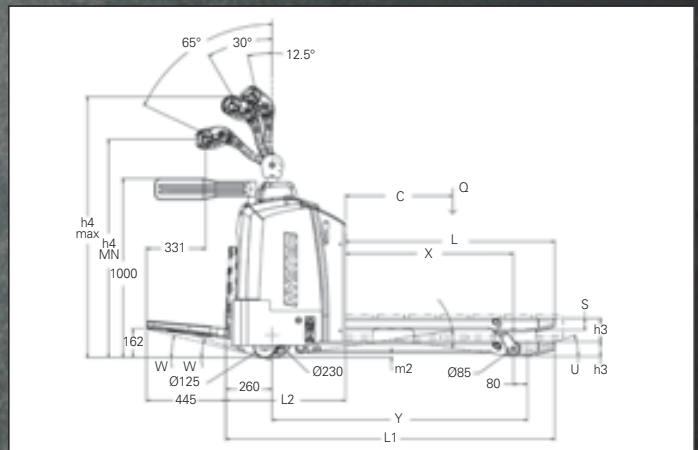
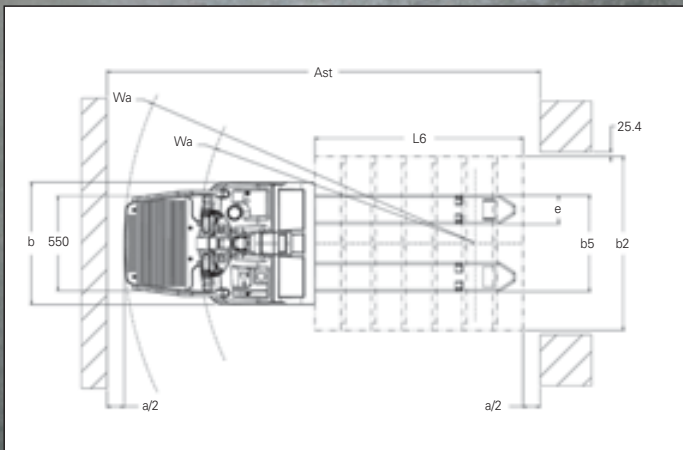



HYSTER® DEALERS

Contact your nearest Hyster Dealership
by visiting www.hyster.com



Contact your local Hyster Dealer



Safety. This truck conforms to the current EU requirements. Specification is subject to change without notice.



HYSTER ASIA PACIFIC

1 Bullecourt Avenue, Milperra NSW, Australia 2214

Tel: +61 (2) 9795 3800 Fax: +61 (2) 9792 8484



/Hysterasiapacific



@Hyster_AP

is a Registered Trademark.

HYSTER is a Registered Trademark. STRONG PARTNERS. TOUGH TRUCKS. is a trademark in the United States and certain other jurisdictions.
© Hyster Asia Pacific 2013. All rights reserved. Printed in Australia. Specifications and details in this brochure are subject to change without prior notification. Please consult with your Hyster dealer for the most up to date information and to confirm exact capacities. BR000020/V1.0

HYSTER.COM