

adaptalift

forklift hire ■ sales ■ service ■ parts



H40-50XM-16CH

40 000 - 50 000 KG

**LADEN CONTAINER
HANDLING TRUCKS**



**THE SOLUTION TO YOUR
APPLICATION NEEDS**

13 22 54

aalhysterforklifts.com.au

BUILT ON EXPERIENCE

The H40-50XM-16CH range of dedicated container handlers is the 6th generation of a proven machine.

These trucks build on more than 40 years of Hyster experience in providing solutions to the container handling industry.



- Container handlers equipped with a mast are receiving renewed interest from terminal operators, because these 'first row container stackers' perform container shunting operations faster than most reachstackers.
- The 'masted' Hyster H40-50XM-16CH trucks represent a refreshing concept, purposely developed to deliver these high 'box-rates' in first row stacking operations, at the lowest possible operational costs.
- The location of the operator compartment – towards the rear of the machine - is unique and unconventional.
- Although well accepted on empty container handlers, Hyster was the first manufacturer to apply the rear-mounted cab concept for laden container handlers, as it provides truly excellent all-round visibility.
- The key benefit of this layout is that any obstruction to the operator's forward visibility is greatly reduced. Forward visibility is comparable to most reachstackers. Rearward visibility is outstanding.
- The H40-50XM-16CH series of 'first row container stackers' have been developed using the experiences gained through the manufacture to-date of over 1000 Hyster 'masted' container handlers.
- Constructed using proven components, these trucks feature the chassis and the complete drivetrain of the Hyster ReachStacker.



- The Hyster designed 'Vista' mast, the supremely simple dedicated carriage and the container spreader are proven components, as featured on hundreds of Hyster container handlers, which have been in operation for many years.
- The machine features the Hyster 'Vista' operator compartment, as offered on other Hyster products. It has industry-leading ergonomics, and provides superior driver comfort and excellent all-round visibility.



H40-50XM-16CH

40 000 - 50 000 KG

LADEN CONTAINER HANDLING TRUCKS

VISIBILITY

- The rear-mounted cab position offers an optimum level of all-round visibility that is unique in this product segment.
- The driver is able to maintain a complete 40ft container in his line of sight, during the entire handling operation with minimal head movement.
- The driver has an excellent view of the job at hand, not only thanks to the cab position itself, but also the extensive glass area and the position of the dash display (mounted on the right hand side). Upward visibility is also virtually free from obstruction, thanks to a clever overhead guard design.
- The 'Vista' mast has extremely wide-spaced channels that allow for greater visibility.



PERFORMANCE

Fast, economic handling is the prime benefit of the Hyster 'first row stacker' container handler.

- Due to the simplicity of the 'straight lift' mast movement and high lifting speeds, these container handling machines perform 'container-shunting' operations faster than most reachstacker type machines.
- The fastest spreader (dis)engagement to/from containers is enhanced by the spreader's floating twistlocks, free mechanical articulation and sideshift movement. Automatic twistlock locking, the lift and overlowering inhibitor and spreader rotation and reach are all important standard features that help boost productivity.
- Automotive style driver layout and logical joystick type combi-control help the operator to sustain a high performance level.
- Endurance is also provided through the truck's cooling system that is suitable for operation in ambient temperatures up to 50°C. The hydraulically driven cooling fan only operates on-demand, consuming less energy, improving fuel economy and reducing average noise.



POWER AND PERFORMANCE

STAGE IIIB ENGINE:

For use mainly within EU (European Union) countries, trucks with Stage IIIB diesel engines have significantly reduced exhaust gas emissions. Also by applying Hyster Intelligent Design criteria, these trucks are not only cleaner running but also more economical, achieving up to a 20% fuel saving.

NOTE: A Stage IIIB engine must run on Ultra Low Sulphur Diesel (ULSD) fuel, with a maximum of 15 ppm sulphur content. Diesel fuel with a higher sulphur content than 15 ppm will compromise the emissions performance of the Stage IIIB engine and may result in damage to components.

- The new Stage IIIB compliant Cummins QSL9 9-litre engine has a maximum performance of 276 kW (370 Hp) at 1900 rpm and maximum torque of 1491 Nm at 1500 rpm.
- The transmission available as standard with the engine is the TE-27 series, with the TE-32 available as an option, featuring 4-speeds with APC216 automatic gear shifting, protective forward-reverse shifting lock-out and transmission protection system.



POWER AND PERFORMANCE

STAGE IIIA ENGINE:

This existing diesel engine conforms to Stage IIIA emission standards and will be supplied into markets where the NRMM (Non Road Mobile Machinery) Stage IIIB legislation does not apply.

- The Stage IIIA Cummins QSM 11 6-cylinder diesel engine features a turbo-intercooler engine delivering 224 kW (300 Hp) at 1800 - 2100 rpm.
- Very smooth torque characteristic, with max. 1424 Nm between 1000-1400 rpm, resulting in excellent lifting and acceleration power, combined with low fuel consumption.
- Engine protection system, with derate function on high coolant temperature and/or low oil pressure.
- Heavy-duty air cleaner, with two-stage filter plus a cyclonic pre-cleaner, suitable for dusty operating environments.
- Cooling system suitable up to 50°C. The hydraulically driven cooling fan only operates on-demand, consuming less energy, improving fuel economy and reducing average noise.
- Fuel Tank: 890 litres.

TRANSMISSION

- The S.O.H. model TE-27 powershift transmission has fully automatic 'APC216' soft-shift 4-speed gear change and an electronic 'inching' function, plus a protective lock-out, to help prevent forward to reverse shifting while on the move.
- Back-up alarm sounds when in reverse gear.

AXLES

- Drive axle with double reduction and one-piece drive shafts, with multiple wet disc brakes with cooling system.

BRAKES

- Service brakes: Oil cooled, multiple wet disc brakes on the front wheels, hydraulically charged by accumulator, with cooling system.
- Parking brake: Spring actuated and hydraulically released, acting on the drive shaft. Parking brake is automatically applied when hydraulic pressure falls below 100 bar.
- Steer axle with single steering cylinder and nonadjustable tie-rods. Wheel nut protection.
- 18.00 x 25 wheels fitted all-round.



HYDRAULIC SYSTEM

- E-hydraulics, proportional controls and optional soft start / stop improve controllability and durability.
- Pumps: Two variable-displacement piston pumps, with a total performance of maximum 585 l/min.
- Hyster two-speed system with regenerative function results in high lift speeds.
- Leak-free ORFS (O-ring) type fittings are used throughout the whole machine.
- When hydraulic temperature is too low for operating conditions, the engine will derate. To prevent overheating of the hydraulic oil, an option is available which will reduce truck speed, giving time for the oil to cool down to the correct operating temperature.
- Filtration: Extremely efficient filtration, with new breathers. Full-flow return line filter with 5 micron cartridge on the main system, plus in-line pressure filter with 5 micron on power assist and support systems.
- Large oil cooler for the hydraulic system, suitable for working in ambient temperatures of up to 50°C.
- 6000 hrs oil service interval means lower service cost.
- Hydraulic oil tank: 600 litre useable volume, with level and temperature gauge and magnetic drain plugs, providing additional cooling and reserve capacity.
- Hydraulic control program for easy status and diagnostics and custom settings. Hydraulic temperature protection means lower service costs and improved uptime.

SPREADER SPECIFICATIONS

Hyster 20'-40' Telescopic top lift spreader for handling ISO containers with a height of 8' to 9'6", features:

- Pendular floating ISO twistlocks.
- Automatic twistlock locking (manual locking also possible). Unlocking is done manually.
- 434 mm total sideshift - 217 mm each side.
- 5° Free mechanical sideways articulation (horizontal self-levelling).
- 9° Hydraulic powered slew (4.5° each side) or 210 mm of forward / backwards reach movement.
- Twistlock indicator flags on the spreader corners.
- Twistlock indicator lights in the cab, and on the spreader.
- Twistlock lock-out device, built into the spreader, to help prevent: - engaging a container by less than 4 corners, - unlocking when carrying a container.
- Lift interrupt system, to prevent lifting a container with partially turned twistlocks.
- Anti-slack function to help prevent the mast over-lowering / the lift chains slackening.
- 'Gather guides' near the two rear twistlocks, for easier spreader engagement.
- 4 Lifting eyes, on the 4 corners of the end-beams of the telescopic container spreader, for lifting general cargo.
- 2 Wide-beam work lights on the spreader, pointed to the rear twistlocks.



OPERATOR COMPARTMENT

HYSTER 'VISTA' CAB WITH INDUSTRY LEADING COMFORT AND VISIBILITY.

COMFORT:

- Optional air-conditioning with manual temperature control or climate control.
- Filtered fresh air inlet.
- Heater with 3-stage blower.
- Spacious rubber floored, easy to clean operator compartment is mounted on anti-vibration isolators and features a low noise level of only 73 dB(A) at drivers ear.
- Fully adjustable suspension seat with armrests, high backrest and safety belt. (Optional: air-suspension seat).
- Sliding windows in cab doors.
- Door locking device while driving with the doors open.

CONTROLS:

- Seat mounted console with joystick.
- Joystick control for lift, tilt and spreader functions - sideshift, rotation / slewing and reach / retract. (twistlock locking is automatic). Proportional control for spreader rotation function. Functions operated by separate toggle switches are spreader telescoping and twistlock unlocking.
- Directional lever with forward / reverse shifting protection.
- Auto-shift function (manual shifting possible).
- Finger light steering. Steering column adjustable in height and angle. Small steering wheel with spinner knob.
- Responsive hydraulic brakes and automotive style pedal layout.
- Automatic 'throttle-up' function when lifting: When operating the lifting function, either when not in gear or when the inching pedal is pushed, the engine automatically revs up to 1800 rpm. When in gear, the 'auto-throttle-up' function is deactivated. This gives additional fuel savings as the optimum engine rpm is 'auto-matched' to the hydraulics performance requested by the operator.
- Optional drive speed on load limits vehicle speed between 7 km/h and maximum speed, depending on load weight and height. It can be set to user preferences.
- Improved controllability of functions:
 - Optional pre-defined user modes (smooth, medium, or direct).
 - Optional soft start/stop of hydraulic functions.



VISIBILITY

- Extensive glass area. Lightly tinted glass.
- Clever overhead guard design.
- Effective hot air demister system with various outlets.
- Wipers and washers on front, top and rear window.
- Large front window with effective H-shape twin wipers.
- Two panorama type rear view mirrors.
- Spreader indicator lights positioned at the front cab roof.

INSTRUMENTS AND CONTROLS

- Conveniently side-positioned dash display with central warning device on steering column.
- Analogue display for: Hour meter, Fuel level, Battery charge, Engine oil pressure and coolant temperature, Transmission pressure and temperature.
- Warning lights for: Lights on, Wiper and washer functions, Battery charge, Low brake pressure.
- Audible warning for: Low brake pressure, Back up alarm when in reverse gear.

LIGHTS

Extensive Light kit, consisting of:

- 4 front working lights on the cab, halogen, for 20' and 40' positions.
- 2 rear facing working lights, halogen, on the cab.
- 2 drive lights and 2 front marker lights.
- 2 tail and stop lights.
- 4 direction indicator lights.
- Orange flashing beacon on the cab.
- Two wide beam working lights, halogen, on the container spreader.

ELECTRICS

- 24 V system, 70 A alternator, battery 200 Ah (20 hr.).
- All sealed connectors.
- Battery master switch.



H40-50XM-16CH

40 000 - 50 000 KG

LADEN CONTAINER
HANDLING TRUCKS

OPTIONAL EQUIPMENT

- 2-High stacking configuration: Equipped with min. 4270 mm BOF lift height mast (lowered height 5106 mm). Fitted with a 650 mm lower cab position (to enable clear through mast visibility underneath a 2-high raised 9'6" high container). Includes tilting cab for service access.
- Special paint (RAL) colour(s).
- Radial type tyres.
- Central greasing system, on truck and spreader.

OPERATOR CONVENIENCE / CAB OPTIONS

- Mast tilt indicator (mechanical).
- Deluxe air suspended seat, instead of mechanically suspended seat. Also available with seat heating.
- Air-conditioning system integrated into the heating and ventilation system. It is available with either manual temperature control or climate control. Sunshade screens are fitted on the top and rear windows.

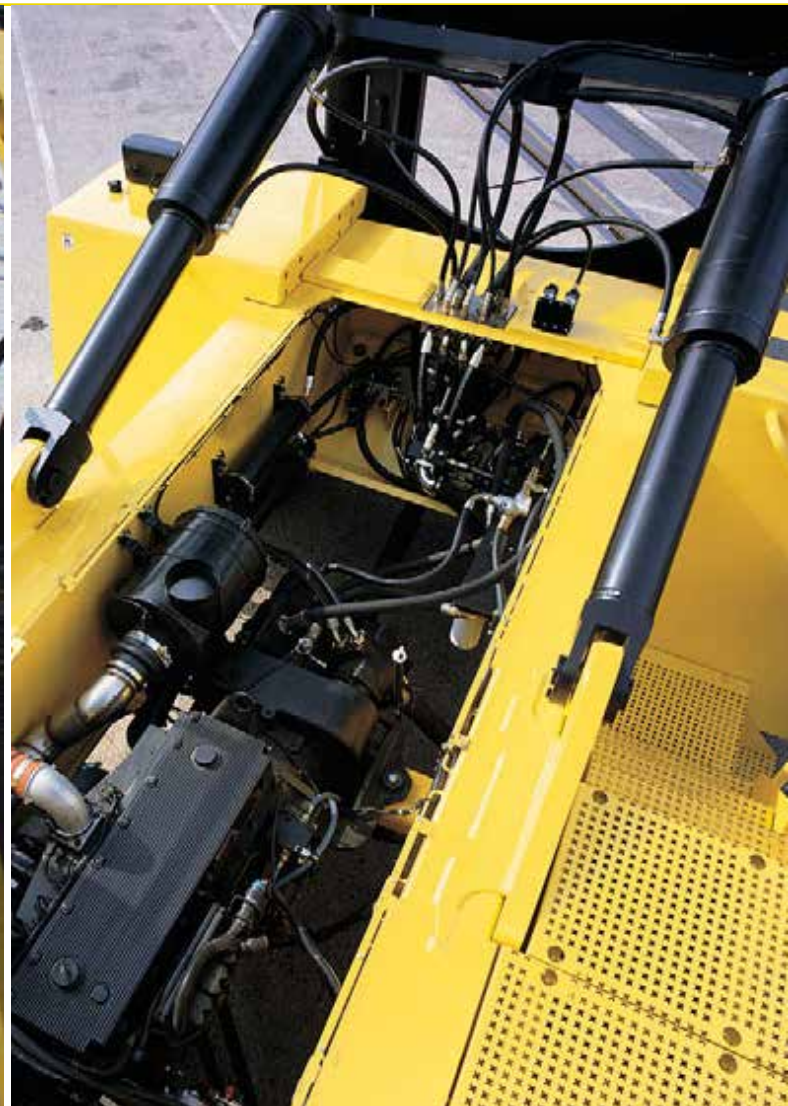

SPREADER OPTIONS

- Half-high mounted dedicated carriage & spreader, to also handle 4' and 4'3" half-height containers. A mast with min. 1.22 m more lift height is selected to keep the same total maximum container stacking height.
- Extra load distance of 127mm on a high-mounted dedicated carriage & spreader. The extra distance may facilitate easier handling from/on wide railway wagons.
- 30' Automatic stop, required for handling (a) 30' container(s).
- 4 Extra lifting eyes underneath the centre of the spreader.

(Note: 4 corner lifting eyes are standard)

SERVICE ACCESS

- Engine and transmission check points are directly accessible via two top covers.
- Engine, transmission and hydraulic components are easily accessible by lifting off the aluminium top covers.
- Large compartments doors and openings are situated on both sides of the machine.



H40XM-16CH, H44XM-16CH, H48XM-16CH , H50XM-16CH

CHARACTERISTICS	1.1 Manufacturer		HYSTER		HYSTER		HYSTER		HYSTER	
	1.2 Model designation		H40XM-16CH		H44XM-16CH		H48XM-16CH		H50XM-16CH	
	1.3 Power: Battery, Diesel, LPG, Electric mains		Diesel		Diesel		Diesel		Diesel	
	1.4 Operation: manual, pedestrian, stand, seat, orderpicker		Seat		Seat		Seat		Seat	
	1.5 Load capacity	Q (kg)	34,700	31,900	39,600	35,600	40,000	39,400	40,000	40,000
	1.6 Load centre	c (mm)	1,400	1,610	1,400	1,610	1,400	1,610	1,510	1,720
	1.8 Load distance	x (mm)	870		870		870		900	
	1.9 Wheelbase	y (mm)	5,900		5,900		5,900		5,900	
WEIGHTS	2.1 Unladen weight	kg	60,963		63,560		67,685		73,400	
	2.2 Axle loading with load, front / rear	kg	90,065	5,598	94,940	8,220	101,202	6,483	104,091	9,302
	2.3 Axle loading without load, front / rear	kg	40,843	20,120	40,100	23,460	44,462	23,223	47,249	26,143
WHEELS & TYRES	3.1 L = pneumatics, V = solids, SE = pneumatic-shaped solids		L		L		L		L	
	3.2 Tyres size, front		18.00 x 25		18.00 x 25		18.00 x 25		18.00 x 25	
	3.3 Tyres size, rear		18.00 x 25		18.00 x 25		18.00 x 25		18.00 x 25	
	3.5 Number of wheels, front / rear (X driven)		x 4	2	x 4	2	x 4	2	x 4	2
3.6 Track width, front	b10 (mm)	3,030		3,030		3,030		3,030		
3.7 Track width, rear	b11 (mm)	3,075		3,075		3,075		3,075		
DIMENSIONS	4.1 Mast tilt: forward / backwards	degree	6°	10°	6°	10°	6°	10°	6°	10°
	4.2 Height of mast lowered	h1 (mm)	6,584		6,584		7,956		7,993	
	4.3 Minimum height of twistlocks (mast lowered)	h13 (mm)	2280		2280		2280		2280	
	4.4 Lift height	h3 (mm)	7,010	3 high	7,010	3 high	9,755	4 high	9,755	4 high
	4.5 Height of mast, extended	h4 (mm)	10,576		10,576		13,321		13,321	
	4.7 Cab height	h6 (mm)	4,660		4,660		4,660		4,660	
	4.8 Seat height	h7 (mm)	3,525		3,525		3,525		3,525	
	4.19 Overall length	l 1 (mm)	10,330		10,330		10,330		10,485	
	4.20 Length without spreader	l 2 (mm)	7,710		7,710		7,710		7,740	
	4.21 Overall width	b2 (mm)	4,200		4,200		4,200		4,200	
	4.23 Spreader type		ISO 20' - 40'		ISO 20' - 40'		ISO 20' - 40'		ISO 20' - 40'	
	4.24 Pile slope	degree	+/-2,5°	mechanically	+/-2,5°	mechanically	+/-2,5°	mechanically	+/-2,5°	mechanically
	4.24 Overall width, 20' spreader	b3 (mm)	6,100		6,100		6,100		6,100	
	4.28 Spreader slew and reach	l 4 (mm)	+/- 4.5° / 210 mm		+/- 4.5° / 210 mm		+/- 4.5° / 210 mm		+/- 4.5° / 210 mm	
	4.30 Side shift movement	b8 (mm)	432 (+/- 216)		432 (+/- 216)		432 (+/- 216)		432 (+/- 216)	
	4.31 Ground clearance, under mast with load	m1 (mm)	458		458		458		357	
	4.32 Ground clearance, centre of wheelbase	m2 (mm)	335		335		335		240	
4.33 Stacking aisle, 20' / 40', without operating clearance	Ast (mm)	11,430	14,045	11,430	14,045	11,430	14,045	11,595	14,045	
4.33 Stacking aisle, 20' / 40', with 200 mm operating clearance	Ast (mm)	11,630	14,245	11,630	14,245	11,630	14,245	11,795	14,245	
4.33 Stacking aisle, 20' / 40', with 10% operating clearance	Ast (mm)	12,575	15,450	12,575	15,450	12,575	15,450	12,755	15,450	
4.35 Turning radius	Wa (mm)	7,875		7,875		7,875		7,875		
4.36 Distance from centre of truck to centre of inner turning circle	b13 (mm)	2,690		2,690		2,690		2,690		
PERFORMANCE	5.1 Travel speed with / without load	km/h	20	22	20	22	20	22	20	22
	5.2 Lifting speed with / without load with Stage IIIA QSM engine @ 2100 rpm ●	m/s	0.24	0.26	0.24	0.26	0.24	0.26	0.24	0.26
	5.2 Lifting speed with / without load with Stage IIIB QSL engine @ 2000 rpm ●	m/s	0.25	0.27	0.25	0.27	0.25	0.27	0.25	0.27
	5.3 Lowering speed with / without load	m/s	0.50	0.50	0.50	0.50	0.50	0.50	0.50	0.50
	5.5 Drawbar pull with / without load †	kN	312	228	310	241	310	241	309	254
	5.8 Gradeability with / without load ♦	%	29	40	26	40	25	38	24	39
	5.10 Service brake		Oil-immersed brakes		Oil-immersed brakes		Oil-immersed brakes		Oil-immersed brakes	
POWER UNIT	7.1 Engine manufacturer / type		Cummins QSM11 (Stage IIIA) / Cummins QSL9 (Stage IIIB)							
	7.2 Engine power, in accordance with ISO1585, Stage IIIA: max @ 1800 rpm / nominal @ max 2100 rpm	kW (hp)	Stage IIIA: 224 (300) / 216 (290); optional Stage IIIA: 272 (365) / 261 (350)							
	7.2 Engine power, in accordance with ISO1585, Stage IIIB: max @ 1900 rpm / nominal @ max 2100 rpm	kW (hp)	"Stage IIIB: 276 (370) / 261 (350)							
	7.3 Governed speed	min ⁻¹	2,100							
7.4 Number of cylinders / displacement	/ cm ³	QSM11: 6 / 10800 QSL9: 6 / 8900								
OTHER	8.1 Drive control		4-speed autoshift SOH TE27 optional SOH TE32							
	8.2 Working pressure for attachments	bar	235							
	8.3 Oil flow for attachments	l/min	90							
	8.4 Noise level L _{PAZ} , inside cab, per EN12053 ☉	dB (A)	QSM11: 78 QSL9: 73							
	8.5 Towing coubling model / type		no							

Equipment and weight:

Weights (line 2.1) are based on the following specifications: Complete truck with cab, pneumatic tyres, mast as specified, dedicated carriage and 20' – 40' spreader.

Truck Dimensions

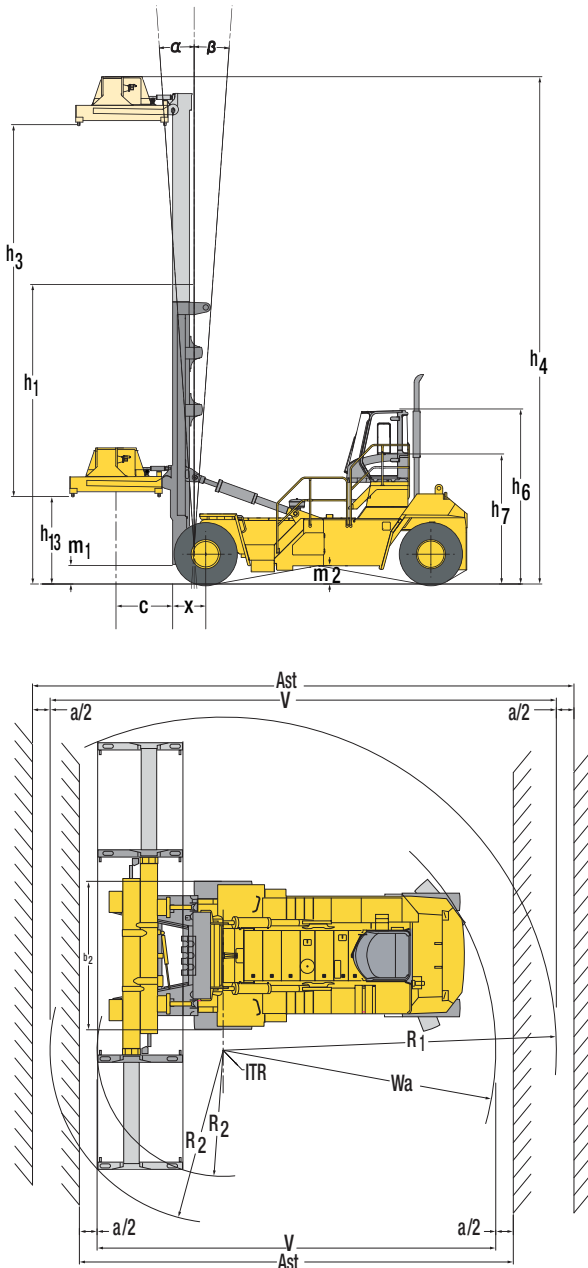

- r1 = radius of swing of container rear corner
- r2 = radius of swing of container front corner
- Wa = outside turning radius of the truck
- a = total operating clearance, a/2 is operating clearance at each side
- a = 10% of V
- V = (theoretical) 90° stacking aisle width, no intrusive stacking
= r2 + the larger of r1 or Wa
- Ast = (practical) 90° stacking aisle, no intrusive stacking and with clearance
= V + a = V + 10%

NOTE:

Specifications are affected by the conditions of the vehicle and how it is equipped, as well as the nature and condition of the operating area. If these specifications are critical, the proposed application should be discussed with your dealer.

- ◆ Gradeability figures (line 5.8) are provided for comparison of tractive performance, but are not intended to endorse the operation of the vehicle on the stated inclines. Follow instructions in the operating manual regarding operation on inclines.
- † Drawbar pull performance figures are only indicative for comparison purpose. These performances are only possible for a short period of time.
- Lift speeds with 365kW engine
- ⊛ LPAZ, measured according to the test cycles and based on the weighting values contained in EN12053

All specifications and capacities quoted in the mast and capacity information tables are valid for trucks equipped with a Hyster container handling attachment and for handling ISO containers, which are 8' wide and 8'6" - 9'6" high.

Hyster products are subject to change without notice. Lift trucks illustrated may feature optional equipment. The capacities quoted are in conformance with standards ISO 1074 and 10525.

CE Safety: This truck conforms to the current EU requirements.

H40-50XM-16CH

40 000-50 000 KG

LADEN CONTAINER
HANDLING TRUCKS

MAST AND CAPACITY INFORMATION

	Stacking height & container height	Recomm. Mast lift height BOF (mm)	Mast lowered height (mm)	Maximum under twistlocks (mm)	H40XM-16CH	H44XM-16CH	H48XM-16CH	H50XM-16CH
					spreader reach retracted/extended	spreader reach retracted/extended	spreader reach retracted/extended	spreader reach retracted/extended
3 HIGH	8'6"	7010	6476	9290	37100 / 33400	39900 / 35950	40000 / 40000	N/A
	9'6"							
4 HIGH	8'6"	9755	7847	12035	35300 / 31750	39300 / 35400	40000 / 39590	40000 / 40000*
	9'6"							
5 HIGH	8'6"	12650	9332	14930	N/A	N/A	38340 / 35310*	40000 / 40000*
	9'6"							

*5-High mast and the H50.00XM-16CH are with: Heavy Duty mast and 30 mm extra load distance on dedicated carriage

- Stacking heights up to 5-high 9'6" containers.
- Ability to stack up to 40 tonne containers.
- Hyster 2-stage 'Vista' mast has large channel overlaps to ensure excellent strength and durability and to minimize flexing during stacking.
- Wide mast and front axle gives immensely improved forwards visibility and added sideways stability for stacking heights up to 5-high 9'6" containers.
- Uniquely simple routing of the hydraulic functions over the mast to the spreader, by only two hoses and two cables.





Branches

VICTORIA

Melbourne - Springvale (Head Office)

📍 1574 Centre Rd
Springvale, VIC, 3171
☎ [03] 9547 8000

Melbourne - Truganina

📍 42-44 Jessica Way
Truganina, VIC, 3029
☎ [03] 9394 4000

TASMANIA

Tasmania

📍 87a Devonport Road
Spreyton, TAS, 7310
☎ [03] 6427 3966

NEW SOUTH WALES

Sydney (State Office)

📍 219 Newton Rd
Wetherill Park, NSW, 2164
☎ [02] 8788 1777

Riverina

📍 5 Favell Street
Griffith, NSW, 2680
☎ [02] 6962 7343

Newcastle

📍 3/46 Munibung Rd
Cardiff, 2285
☎ [02] 4954 7724

WESTERN AUSTRALIA

Perth (State Office)

Unit 1, 1-9 Kurnall Road
Welshpool, WA, 6106
☎ [08] 9352 9200

QUEENSLAND

Brisbane (State Office)

📍 11 Lombank Street
Acacia Ridge, QLD, 4110
☎ [07] 3373 5111

Rockhampton

📍 62 Glenmore Road
Park Avenue, Rockhampton
QLD 4700
☎ [07] 4922 8874

Townsville

📍 39 Duckworth Street
Garbutt, QLD, 4814
☎ [07] 4778 2000

SOUTH AUSTRALIA

Adelaide (State Office)

📍 18-22 Churchill Rd. Nth.
Dry Creek, SA, 5094
☎ [08] 8360 3444

Mt. Gambier

📍 1 Avey Road
Mt. Gambier, SA, 5290
☎ [08] 8725 7809

Service Centres

VICTORIA

Bendigo
Warrnambool
Ballarat
Shepparton
Wodonga
Mildura

TASMANIA

Hobart
Launceston
Burnie

NEW SOUTH WALES

Dubbo
Griffith
Tamworth
Newcastle
Wollongong
Canberra
Tumut
Bathurst
Wagga Wagga
Albury
Gosford
Coffs Harbour

SOUTH AUSTRALIA / NT

Riverland
Darwin

QUEENSLAND

Rockhampton
Mackay
Cairns
Gladstone
Townsville
Mt Isa
Toowoomba
Gold Coast
Sunshine Coast

WESTERN AUSTRALIA

Margaret River
Karratha



13 22 54

aalhysterforklifts.com.au