



Sit-Down, Counterbalanced IC, Cushion Tire **FORTIS**® Line

S80-120FT Series



STRONG PARTNERS. TOUGH TRUCKS.™



S80-120FT SERIES

The S80-120FT is more than a new lift truck series. It represents a transformation in how lift trucks are designed, built and acquired. Drawing on Hyster Company's legacy of strength, durability and toughness, the Fortis® concept simplifies lift truck purchases with a three-tiered system of preconfigured engine-transmission bundles. Fortis means you maximize your purchasing power by buying only the features you need for your application. Using a truck from the S80-120FT series means low cost of operations, dependability and owning a unit that's still going strong long after the day's work is done.

THE HYSTER® S80-120FT SERIES ADVANTAGE

The S80-120FT series is configured to provide the right lift truck for your application. Our three truck packages with multiple powertrain combinations to choose from assure your cost of operations will be lowered. Each configuration offers improved efficiency, advanced dependability and simple serviceability.

	FORTIS®	FORTIS® ADVANCE	FORTIS® ADVANCE+
DESIGN INTENT			
Investment	Lowest Upfront Investment	Minimized Operating Costs	Maximum Performance
POWERTRAIN CONFIGURATION			
Engine	GM 4.3L, LP, V6, 98 HP	GM 4.3L, LP, V6, 98 HP	GM 4.3L, LP, V6, 98 HP
Transmission	Standard electronic powershift	DuraMatch™	DuraMatch™ Plus
Brakes	Premium drum brakes	Premium drum brakes	Oil-cooled wet disc brakes
Cooling System	Heavy-duty anti-clog radiator	Combi-cooler radiator	Combi-cooler radiator
Hydraulics	Cowl mounted levers	Cowl mounted levers	TouchPoint™ E-hydraulics



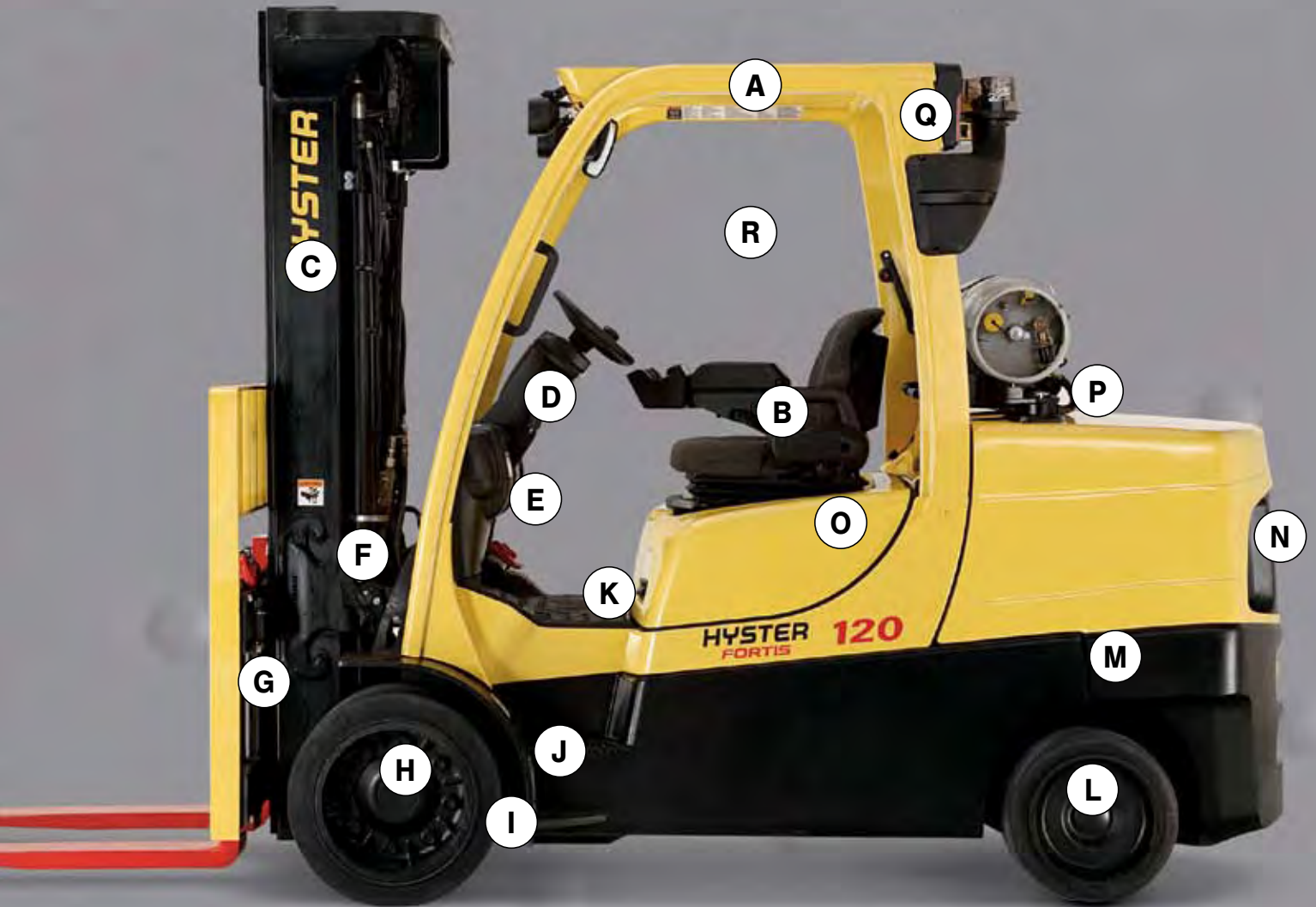

Trucks shown with optional equipment.

S80-120FT

A. Overhead Guard (OHG)

The unique grid-style pattern improves visibility while protecting operators and strengthening the truck's structure. The front, curved OHG leg design affords greater shoulder clearance for easier operator entry and exit.

B. Hydraulic Controls

The Hyster® Fortis® line of lift trucks offers three configurations that employ cowl mounted levers, TouchPoint™ mini-levers or a TouchControl™ joystick to provide you unsurpassed, low effort, tactile control of all hydraulic functions.

C. Exclusive VISTA® Mast

High strength hot-rolled steel mast channels and flush-faced design improve capacity retention at high lifts. Compact cast steel cross members optimize visibility and rigidity. Six canted 3-inch full-face load rollers roll on the web and the flange simultaneously, eliminating the need for side thrust rollers or wear plugs.

D. Tilt Steer Column

The infinitely adjustable tilt steer column accommodates operators easily. Assisted by a gas-spring and an easy-to-reach lever, obtaining your preferred position is simple. The standard 12-inch steering wheel with integrated spinner knob reduces fatigue while providing more knee room. And it goes lock-to-lock in just 4 turns for superior efficiency, maneuverability and control.

E. Pacesetter VSM™

The computer "brain" of the Fortis® line of lift trucks manages all vehicle systems to optimize performance and significantly increase overall reliability and enhance diagnostic capabilities for maximum uptime.

F. Hassle-Free Hydraulics

Use of leak-free O-ring face seals helps maximize uptime. In-tank filter increases hydraulic fluid filtration by 60% for particles down to 10 microns, significantly extending component life and creating a cleaner overall operation.

G. Integral Sideshift

The optional integral sideshift provides excellent visibility and affords greater capacities than carriage-mounted sideshifts.

H. Heavy-duty Planetary Drive Axle

The full floating design of the drive axle lets the axle housing, not the shafts, carry the weight of the load, enhancing dependability and reliability for a longer service life. Hyster premium self-adjusting brakes provide excellent inching or stopping power.

I. Oil-Cooled Wet Disc Brakes

Provide excellent stopping power and extremely long service life. Brakes are completely sealed from water and dirt making them ready for your harshest environments. (Standard with Fortis® Advance+).

J. Drivetrain Mounting

The Hyster Fortis line of lift trucks has a fully isolated drivetrain through the use of elastomeric mounts for the engine and transmission. The result is a new standard in smooth riding comfort.

K. Removable Floor Plate

One piece, steel floor plate is easily removed to provide incredible service access. A molded rubber floor mat seals the floor area to reduce noise and vibration for a more comfortable ride.

L. Hydrostatic Steer Axle

The elastomeric-mounted Hyster designed cast ductile iron steer axle with transverse, double-acting hydraulic cylinder, tapered roller spindle- support bearings and non-adjustable tie rods provide maximum durability and superior steering control for easy maneuvering and low maintenance.

M. Hyster Stability System

The new stability system reduces truck lean in turns, improving lateral stability. Even with the reduced lean, the innovative steer axle mounting design allows for superior travel over uneven surfaces.

N. Counterweight

The superior design permits a significant increase in airflow to assist the Fortis line of lift trucks to run cooler, even in extreme temperatures and environments.

O. Engine Cover

The tough engine cover is made of a durable, crack-resistant, thermoset polyester resin reinforced with glass. Hinged at the rear, it offers superior service access to the engine compartment with an opening angle of 85 degrees.

P. EZXchange™ Bracket

This optional bracket swings out from over the top of the counterweight and the gas-spring assisted fuel cylinder lowers into a reclined and locked position, providing a stable platform for quick, easy LP tank replacement.

Q. Brake/Backup Lights

For superior functionality, the optional Hyster LED brake/backup lights resist vibration and offer extremely long life.

R. Fatigue-Reducing Operator Compartment

Ergonomically designed compartment plays a big role to enhance overall productivity. Entry and exit are made easy by the optimized step height with non-slip step tread, soft touch contoured hand grip and rounded hood. Repositioned foot pedals provide improved floor space, while better engine cooling keeps operators more comfortable. Infinitely adjustable tilt steer column accommodates any size operator. A formed fiberglass liner provides increased noise suppression for a more comfortable ride.

Decrease Downtime By Up To 30%

Approximately 70% of industrial lift truck downtime results from problems with the powertrain, electrical system, cooling system or hydraulic system. With the S80-120FT, many of these mechanical issues become a thing of the past as design advances have reduced downtime by up to 30%.

Toughest Powertrain

- Pacesetter VSM™ industrial onboard computer monitors and protects the engine powertrain to maximize the S80-120FT series uptime.
- Transmission gears and shafts are up to 15% stronger to handle even the most demanding duty cycle.
- Electronic controlled powershift transmission has state-of-the-art clutch packs that are stronger and larger and provide up to 3 times the life.
- Hyster® drum brakes are self-adjusting and self-energizing with heavy-duty backing plate to provide optimal performance and lengthened service life.
- Optional oil-cooled wet disk brakes provide extremely long service life and are completely sealed from water and dirt making them ready for your harshest environments (standard with Fortis Advance+).

Industrial Strength Electronics

- CANbus communications network reduces wiring complexity, providing superior dependability.
- Non-mechanical, Hall-Effect sensors and switches are designed to outlast the life of the truck.
- Proven tough, Pacesetter VSM industrial onboard computer manages truck operation to maintain world-class dependability to maximize uptime.
- IP66 sealed electrical connectors keep out water and debris, so you can powerwash our trucks.

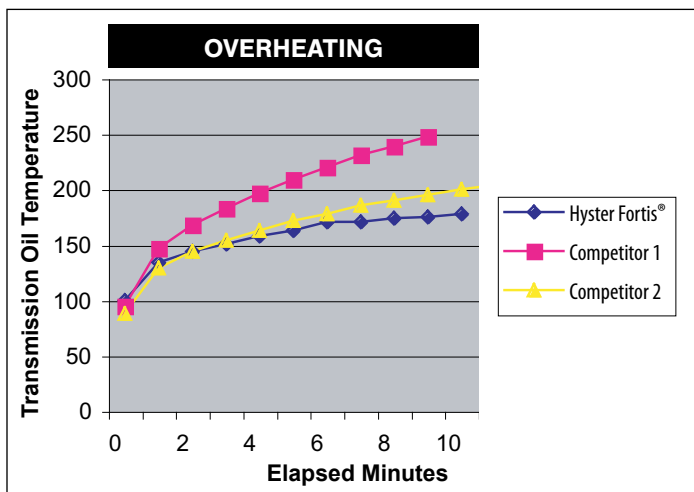

In intensive applications, the S80-120FT Series runs significantly cooler due to the superior cooling system and counterweight design.



- Smart, one-way routing path for wire harnesses ensures consistent high-quality assembly while increasing durability and simplifying maintenance when needed.

Exceptional Cooling

- A choice of 2 aluminum core radiators, each with significant design and component improvements, provides exceptional cooling capacity – a key factor to increasing uptime and the economic life of your trucks.
- Soft rubber isolator mounted radiators increase reliability and durability to significantly extend service life.
- A superior counterweight tunnel design coupled with a “pusher” type fan and enhanced shroud design improves airflow and significantly reduces the recirculation of hot air to maximize cooling capabilities.
- Combi-cooler radiator provides 4-row aluminum core for additional transmission oil cooling capacity for the most demanding and intensive applications. (Standard with Fortis® Advance and Fortis® Advance+)

Hassle-Free Hydraulics

- Leak-free O-ring face seal fittings reduce leaks for enhanced reliability.
- A 10-micron high-performance in-tank filtration system captures 99.5% of hydraulic system debris, significantly extending component life.
- Smart placement of the control valve and hydraulic lines away from heat sources reduces operating temperature, extending the life of seals and hoses for unbeatable reliability.

Save over \$2,400 In Operating Costs Per Lift Truck – Each Year

Lowering operating costs in all types of applications is what the Hyster® S80-120FT Fortis® series does best. In head-to-head comparisons with the leading competitors' comparable trucks, the S80-120FT series was shown to save you over \$2,400 per year in operating consumable costs. This, combined with up to a 30% decrease in downtime, makes the Hyster S80-120FT Fortis series an exceptionally smart choice. The S80-120FT series features 3 truck packages with multiple powertrain configurations that provide improved efficiency, while enhancing reliability and superior serviceability to reduce your operating costs.

World-Class Efficiency

- Auto Deceleration System extends brake life by up to 60% by automatically slowing the truck when the accelerator pedal is released. (Fortis® Advance, Fortis® Advance+)
- Controlled power reversal feature virtually eliminates tire spin, increasing tire life by up to 50%. This feature is programmable to match the needs from delicate to more aggressive settings for maximum productivity. (Fortis Advance, Fortis Advance+)
- Electronic hydraulic control valve precisely manages hydraulic pressure and flow to supply exactly the right amount of power for each function, reducing fuel consumption.
- Hydraulic oil change interval extended from 2,000 to 4,000 hours.
- Improved engine options provide excellent performance with advanced combustion technology that enhances fuel economy.

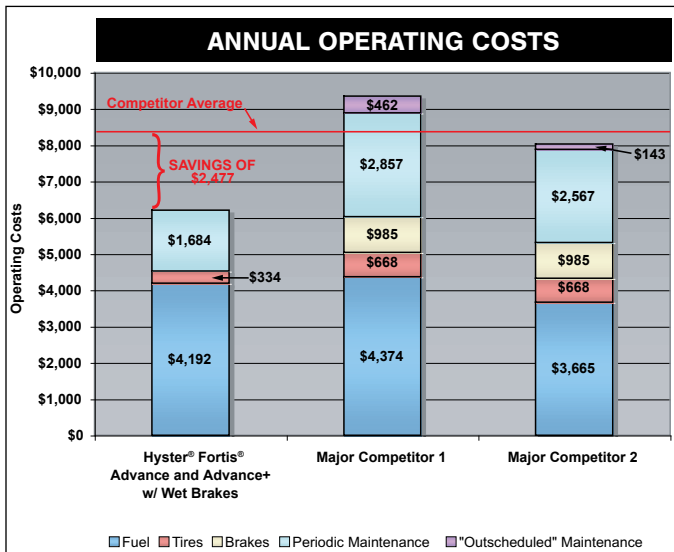

In intensive applications, the Hyster® Fortis Advance and Advance+ truck can save \$2,477 per year. This includes fuel, brakes, tires, and regular periodic maintenance.

Advanced Dependability

- **Toughest Powertrain:** Electronic controlled transmissions reduce shock loading; clutch packs with 3 times the life; 15% stronger gears and shafts; and Hyster premium brakes all work to provide unmatched reliability.
- **Industrial Strength Electronics:** CANbus communications, non-mechanical sensors and switches and IP66 rated sealed connections mean electrical problems are a thing of the past.
- **Industry's Best Cooling:** The S80-120FT series' superior airflow and choice of heavy-duty cooling systems keep heat in check, while providing world-class dependability in even the harshest of environments.
- **Hassle-free Hydraulics:** Leak-free O-ring face seal fittings at all high pressure connection points, superior filtration (10 micron) system and smart placement of valve and lines take the worry out of hydraulics.

Superior Serviceability

- Pacesetter VSM™ continuously monitors fluid levels and powertrain, reducing daily service checks and preventing major repairs.
- Unmatched service access: Rear-opening one-piece hood (opens up 85 degrees) and easy-to-remove one-piece floor plate (no tools required) provide industry's best cowl to counterweight service access.
- Daily checks are easily accessed and performed.
- State-of-the-art onboard diagnostics reduce repair time and minimize expensive parts swapping.
- Optional oil-cooled wet disc brakes virtually eliminate brake maintenance.

DOWNTIME IS COSTLY

Estimated Costs per Downtime Event:	
Repair Costs (parts & labor)	\$ 500
Idle Operator Costs	+ \$ 60
Truck Rental Costs	+ \$ 120
Administrative Costs	+ \$ 50
TOTAL COST (per Downtime Event)	\$ 730
Additional Costs:	+ \$
Lost Productivity and Sales	\$???

Assumptions:
 1. Operator Cost = \$15.00/hr.
 2. Average Length of Downtime Event = 4 hrs.

Superior Operator Comfort

- Low noise level at operator ear lessens driver fatigue, improving driver satisfaction for an overall increase in productivity.
- Isolated drivetrain minimizes the effect of powertrain vibration and road-born shocks to increase operator comfort all shift long.
- Rear drive handle mounted on overhead guard leg (optional) provides an excellent hand hold for reverse driving while giving ready access to the auxiliary horn button for use when approaching cross-aisles and pedestrian traffic areas.
- An infinitely adjustable steer column and optional full suspension seat assures the right fit for any operator.
- Easy-to-use 3-point entry design of operator compartment uses a large molded hand grip and open non-slip step with a low step height to minimize muscle/joint strain during entry/exit.
- Adjustable armrest that accompanies the TouchPoint™ or TouchControl™ E-hydraulic optional configurations moves with the seat and telescopes forward/vertical in one simple movement to provide greater flexibility in achieving a more custom position.
- Swingout bracket frees the LP tank from over the counterweight to simplify changeout.
- Optional EZXchange™ bracket also lowers the tank on its stable platform to minimize arm and back strain for even easier changeouts.
- A choice of 6 different seats enables a more customizable level of operator comfort by its enhanced design and adjustable features.
- Increased shoulder clearance – a result of the redesigned overhead guard and more floor space – gives operators greater foot room.

Precise, Effortless Operation

- Improved brake pedal layout and the minimal braking requirements of the Auto Deceleration System significantly reduce operator fatigue. (Fortis® Advance and Fortis® Advance+)
- 12-inch steering wheel with spinner knob improves steering response, increasing control and efficiency while minimizing shoulder strain with only 4 turns lock-to-lock.



- Controlled rollback on ramps contributes to lower driver fatigue and significantly enhances truck and load control on ramps. (Fortis Advance and Fortis Advance+)
- Optional auto-speed hydraulics with automatic inching control eliminate operator inching requirement while automatically increasing throttle when hydraulic function is actuated, making the S80-120FT series easier and more productive to operate. (Fortis® Advance+)

Performance At-A-Glance

- Advanced dash display uses a non-reflective, backlit LCD screen and 21 indicator lights provide performance at-a-glance in all lighting conditions.
- Easy-to-use onboard diagnostics through the advanced dash display provide fast and accurate troubleshooting for first-time fixes.
- Optional electronic monitoring package reports air and hydraulic oil filter restrictions and low engine coolant levels.

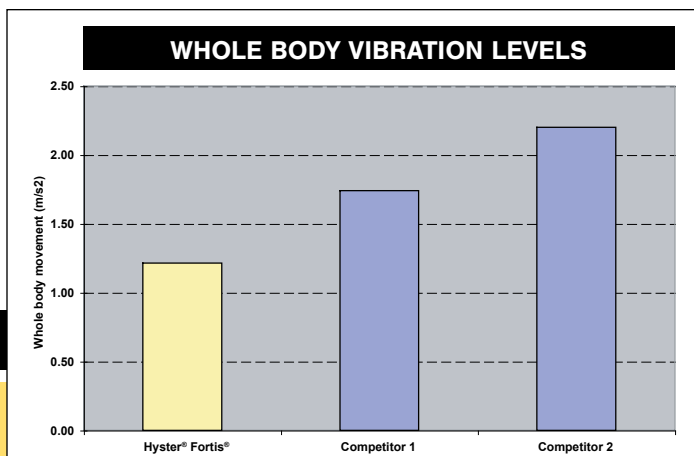

The comprehensive ergonomic design of the S80-120FT Series can help save you money by minimizing the productivity robbing effects of fatigue.

ESTIMATED ANNUAL LIFT TRUCK OPERATOR COSTS	
Costs Related To Fatigue	Average Annual Cost Per Lift Truck Operator
Absenteeism ¹ Turnover ² Lift Truck and Property Damage ³ Workers Compensation ⁴ Productivity/Lost Sales	\$6,862
Potential Savings Level	Average Annual SAVINGS Per Lift Truck Operator
Savings at 10% - 20%	\$686 - \$1,372

- 1 Absentee cost based on national average as published in Facility Management safety study, 2003.
- 2 Average turnover cost according to U.S. Dept. of Labor 2002, 30% of income at \$15/hour for 2,000 hours per year.
- 3 Lift Truck and Property Damage based on data from NMHG Fleet Services.
- 4 Workers Compensation costs are average costs for high and low fatigue environments according to 2004 Shiftwork Practices Survey.

Increase Throughput and Sales Volume While Reducing Operating Costs

Productivity means moving more loads in less time with less cost. The Hyster® S80-120FT Fortis® series increases productivity through performance, ergonomics (operator comfort and control), service time and dependability.

Performance Customized For Your Application

- GM 4.3L, LP, V6 engine
- S80-120FT series choice of performance transmissions, hydraulic controls and cooling system options allows you to customize your truck to optimize the productivity in your application.
- Pacesetter VSM™ industrial onboard computer enables you to adjust and optimize the performance of your S80-120FT trucks.
- Patented DuraMatch™ transmissions provide breakthrough features that include the Auto Deceleration System, controlled rollback on ramps, controlled power reversals and auto-speed hydraulics with automatic inching control to move loads more efficiently with less operator fatigue and product damage.

Superior Operator Control

- Superior ergonomic features like more foot and leg room, 3 choices of hydraulic controls, infinitely adjustable steer column, integrated dashboard display, 12-inch steering wheel with spinner knob, Auto Deceleration System, EZXchange™ tank bracket (optional), 6 choices of seats and the reverse drive handle (optional) enable your operator to maximize productivity.



Superior Serviceability

- Complete cowl-to-counterweight access; convenient daily service checks, the integral dashboard display's onboard diagnostic capabilities and reduced service requirements significantly reduce service times to maximize uptime.

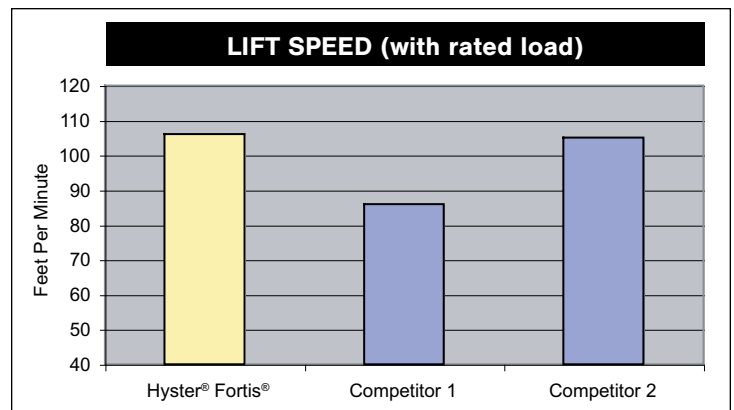
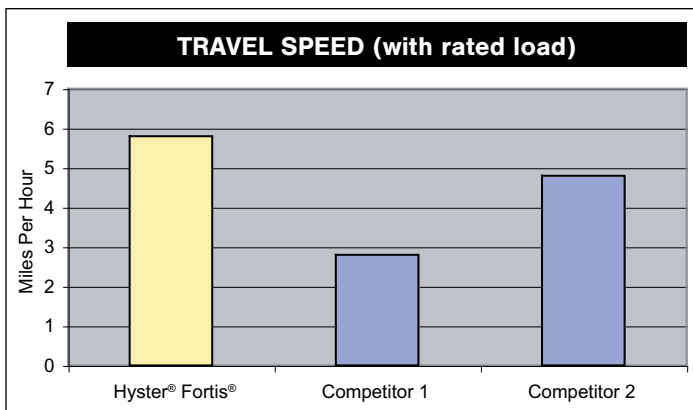

The S80-120FT series boasts faster travel speeds and lift speeds than the competition resulting in enhanced productivity.

Performance Plus+

The Fortis® line of lift trucks represents a breakthrough in how Hyster® lift trucks are being designed, built and acquired. But even the toughest, most durable machine with moving parts will need service at some point. As your strong partners, we are committed to delivering extraordinary aftermarket support to the S80-120FT series that includes a parts availability program which is the fastest and most comprehensive in the industry today – to keep your materials moving at the speed of business today and tomorrow.

Objective:

- To provide world-class product support unparalleled in the industry.

Performance Plus™ Parts Guarantee:

- Off-the-shelf availability guarantee on the parts commonly required in the first two years of use.
- Simply stated, if “Performance Parts” are not available from your local Authorized Hyster Dealer within 1 business day from the date of order – they are free.*
- Please contact your local Hyster Dealer for the details.

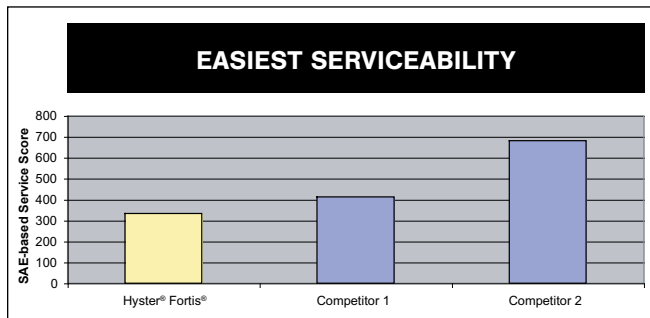

Society of Automotive Engineers (SAE)-based rating evaluating speed and difficulty of over 30 service routines. Lower score indicates easier serviceability.



Industry's Best Warranty:

- One year/2,000 hours on full truck.
- Two years/4,000 hours on powertrain.

Best In Class Serviceability:

- Fastest and easiest lift truck to service based on Society of Automotive Engineers assessment.
- State-of-the-art onboard and PC-based diagnostics available.
- Significantly reduced regular service requirements.

Most Experienced Dealer Network:

- Over 230 dealer locations in North America.
- Dealers average over 30 years of materials handling experience.
- Over 2,500 trained service technicians.
- Rental fleet of over 14,000 lift trucks.

*Contiguous 48 states of the U.S.A. only





S80FT DIMENSIONS

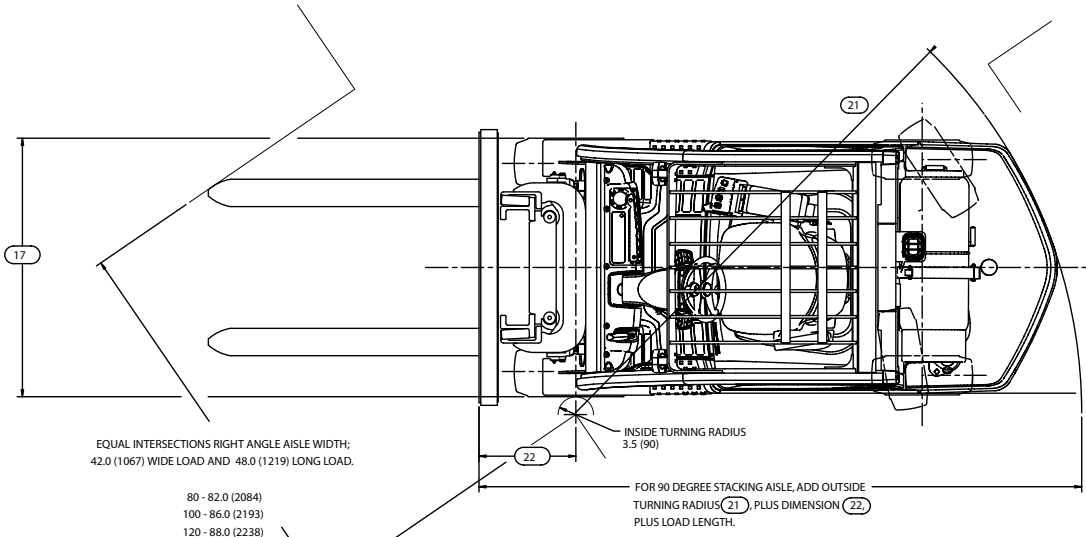

80 - 82.0 (2084)
100 - 86.0 (2193)
120 - 88.0 (2238)

Seat Type	Standard OHG	Optional OHG
Non-Suspension	42.0 (1068)	39.4 (1001)
Semi-Suspension	42.5 (1080)	39.9 (1013)
Full-Suspension	41.8 (1062)	N/A
Swivel Full-Suspension	42.0 (1068)	N/A

TRUCK MODEL	C	D	E	T	X
	in. (mm)	percent	degrees	in. (mm)	in. (mm)
S80FT	24.1 (613)	40%	22.7	4.4 (112)	28.1 (714)

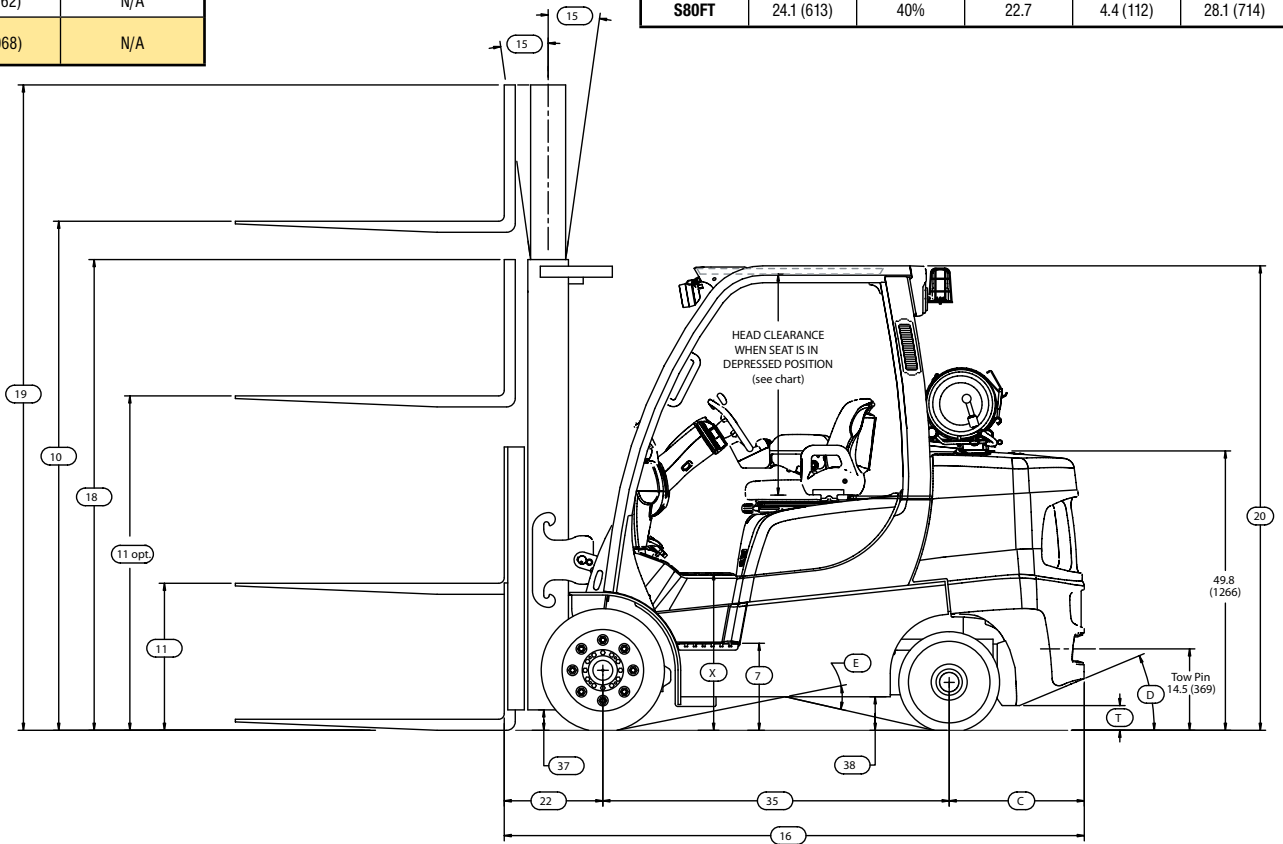

Circled dimensions correspond to the line numbers on the tabulated chart inside the Technical Guide. Dimensions are in inches (millimeters).

CERTIFICATION: These Hyster lift trucks meet design specifications of Part II ANSI B56.1-1969, as required by OSHA Section 1910.178(a)(2) and also comply with Part III ANSI B56.1-revision in effect at time of manufacture. Certification of compliance with the applicable ANSI standards appears on the lift truck.

† NOTE: Performance specifications / ratings are for truck equipped as described under Standard Equipment in this Technical Guide. Performance specifications are affected by the condition of the vehicle and how it is equipped, as well as by the nature and condition of the operating area. Specifications are subject to change and the proposed application should be discussed with your authorized Hyster Company Dealer.

†† Limited by traction. For further information on this dimension, please contact your local Hyster dealer.

S80FT SPECIFICATIONS

13

GENERAL	GENERAL			
	1	2	Hyster Company	Hyster Company
	Manufacturer Name		Hyster Company	Hyster Company
	Model		S80FT	S80FT
	Manufacturer Designation		Fortis®	Fortis® Advance
	Transmission		Electronic Powershift	DuraMatch™ / DuraMatch™ 2
	Rated Capacity	lb. (kg)	8,000 (3636)	8,000 (3636)
	Load Center, Distance	in. (mm)	24 (610)	24 (610)
	Engine / Power Type - Gasoline, LPG, Diesel		GM 4.3L / LP	GM 4.3L / LP
	Operator Type		Sit-Down Rider	Sit-Down Rider
	Step Height	in. (mm)	15.6 (396)	15.6 (396)
	Tire Type - Cushion, Solid, Pneumatic		Cushion	Cushion
	Wheels, Number - Front / Rear		2x / 2	2x / 2
	Lift Height, Top of Fork (TOF)	in. (mm)	120 (3 050)	120 (3 050)
	Lift Heights, Std. Limited Free Lift (LFL) with LBR (TOF)	in. (mm)	5 (150)	5 (150)
	Lift Heights, Optional Full Free Lift (FFL) with LBR (TOF)	in. (mm)	35 (900)	35 (900)
	Standard Carriage Width	in. (mm)	42.0 (1 067)	42.0 (1 067)
	Forks, Thickness x Width x Length	in.	2.5 X 5.0 X 48.0	2.5 X 5.0 X 48.0
	Forks, Thickness x Width x Length	(mm)	(50 X 125 X 1 219)	(50 X 125 X 1 219)
	Fork Spread, Outside Dimensions	in. (mm)	38.3 (972)	38.3 (972)
	Mast Tilt Angles, Forward / Backward	Degrees °	5F / 6B	5F / 6B
	Length To Face of Forks	in. (mm)	103.5 (2 630)	103.5 (2 630)
	Overall Width, Standard Tread	in. (mm)	46.1 (1 170)	46.1 (1 170)
	Overall Width, Wide Tread	in. (mm)	50.0 (1 270)	50.0 (1 270)
	Height, Standard Mast - Lowered	in. (mm)	85 (2 134)	85 (2 134)
	Height, Standard Mast - Extended with LBR	in. (mm)	169 (4 284)	169 (4 284)
	Height, Standard Mast - Extended without LBR	in. (mm)	149 (3 783)	149 (3 783)
	Height, Standard Overhead Guard	in. (mm)	86 (2 175)	86 (2 175)
	Height, Optional Overhead Guard	in. (mm)	83 (2 108)	83 (2 108)
	Turning Radius, Minimum Outside (OTR)	in. (mm)	90.5 (2 298)	90.5 (2 298)
	Length, Center of Wheel to Face of Forks	in. (mm)	17.6 (447)	17.6 (447)
	Aisle Width, Right Angle Stack (Add Length of Load)	in. (mm)	156.1 (3 964)	156.1 (3 964)
	Equal Aisle, 90-Degree Intersecting Aisle	in. (mm)	82.0 (2 084)	82.0 (2 084)
	Travel Speed, Standard Transmission RL/NL	mph (km / h)	10.7 (17.2) / 10.4 (16.7)	10.7 (17.2) / 10.4 (16.7)
	Travel Speed, 2-Speed, Std. Trans. RL/NL	mph (km / h)	—	12.5 (20.1) / 12.1 (19.5)
	Lift Speed, Standard 2-Stage LFL RL/NL	ft. / min (m / s)	120.1 (.61) / 122.0 (.62)	120.1 (.61) / 122.0 (.62)
	Lift Speed, Optional 2-Stage FFL RL/NL	ft. / min (m / s)	106.3 (.54) / 108.3 (.55)	106.3 (.54) / 108.3 (.55)
	Lift Speed, Optional 3-Stage FFL RL/NL	ft. / min (m / s)	112.2 (.57) / 114.2 (.58)	112.2 (.57) / 114.2 (.58)
	Lowering Speed, Standard 2-Stage LFL RL/NL	ft. / min (m / s)	108.3 (.55) / 92.5 (.47)	108.3 (.55) / 92.5 (.47)
	Lowering Speed, Optional 2-Stage FFL RL/NL	ft. / min (m / s)	98.4 (.50) / 70.9 (.36)	98.4 (.50) / 70.9 (.36)
	Lowering Speed, Optional 3-Stage FFL RL/NL	ft. / min (m / s)	104.3 (.53) / 106.3 (.54)	104.3 (.53) / 106.3 (.54)
	Drawbar Pull, Maximum RL/NL†	lb. (kg)	6,923 (3 140) / 3,001 (1 361)	6,923 (3 140) / 3,001 (1 361)
	Drawbar Pull, 2-Speed, Maximum RL/NL†	lb. (kg)	—	7,000 (3 175) / 3,001 (1 361)
	Drawbar Pull @ 1 mph RL/NL†	lb. (kg)	6,175 (2 801) / 3,001 (1 361)	6,175 (2 801) / 3,001 (1 361)
	Drawbar Pull, 2-Speed, @ 1 mph RL/NL†	lb. (kg)	—	6,920 (3 139) / 3,001 (1 361)
	Drawbar Pull @ 3 mph RL/NL†	lb. (kg)	4,800 (2 177) / 3,001 (1 361)	4,800 (2 177) / 3,001 (1 361)
	Drawbar Pull, 2-Speed, @ 3 mph RL/NL†	lb. (kg)	—	5,200 (2 359) / 3,001 (1 361)
	Gradeability @ 1 mph RL/NL†	Percent %	29.8 / 22.6	29.8 / 22.6
	Gradeability, 2-Speed, @ 1 mph RL/NL†	Percent %	—	33.8 / 22.6
	Gradeability @ 3 mph RL/NL†	Percent %	23.0 / 22.6	23.0 / 22.6
	Gradeability, 2-Speed, @ 3 mph RL/NL†	Percent %	—	25.0 / 22.6
	Weight, Standard Truck (2-Stage LFL) NL	lb. (kg.)	13,078 (5 932)	13,078 (5 932)
	Weight, Standard Truck (2-Stage LFL) RL	lb. (kg.)	21,078 (9 932)	21,078 (9 932)
	Axle Loading, Static Front / Rear NL	lb. (kg.)	5,165 (2 343) / 7,912 (3 589)	5,165 (2 343) / 7,912 (3 589)
	Axle Loading, Static Front / Rear RL	lb. (kg.)	19,471 (8 832) / 2,156 (978)	19,471 (8 832) / 2,156 (978)
	Tire Size, Front		22 X 9 X 16	22 X 9 X 16
	Tire Size, Rear		18 X 7 X 12.2	18 X 7 X 12.2
	Wheelbase	in. (mm)	61.8 (1 570)	61.8 (1 570)
	Ground Clearance, Lowest Point NL (with RL less 6mm)	in. (mm)	4.5 (114)	4.5 (114)
	Ground Clearance, Center of Wheelbase NL	in. (mm)	6.0 (152)	6.0 (152)
	Brakes Service - Method of Control / Operation		Foot / Hydraulic	Foot / Hydraulic
	Brakes Park - Method of Control / Operation		Hand / Mechanical	Hand / Mechanical
	Battery Type		Maintenance Free	Maintenance Free
	Volts / Cold Cranking Amps	v / cca	12 / 475	12 / 475
	Engine, Manufacturer		GM	GM
	Permanent Output @ 2400 rpm	hp	98	98
	Torque @ rated RPM	ft Lbs. (kg / m)	210 (285) @ 2400 RPM	210 (285) @ 2400 RPM
	Number of Cylinders / Displacement	No. cc (ci)	6 / 4302 (262)	6 / 4302 (262)
	Transmission Type, Standard		Electronic Powershift	DuraMatch™ / DuraMatch™ 2
	Standard Speeds Forward / Reverse		1-1	1-1 / 2-1
	Auxiliary Hydraulic Pressure Relief for Attachments	PSI (bar)	2250 (155)	2250 (155)

DIMENSIONS

PERFORMANCE †

WT.

TIRES & WHEELS

POWERTRAIN

S100-120FT DIMENSIONS

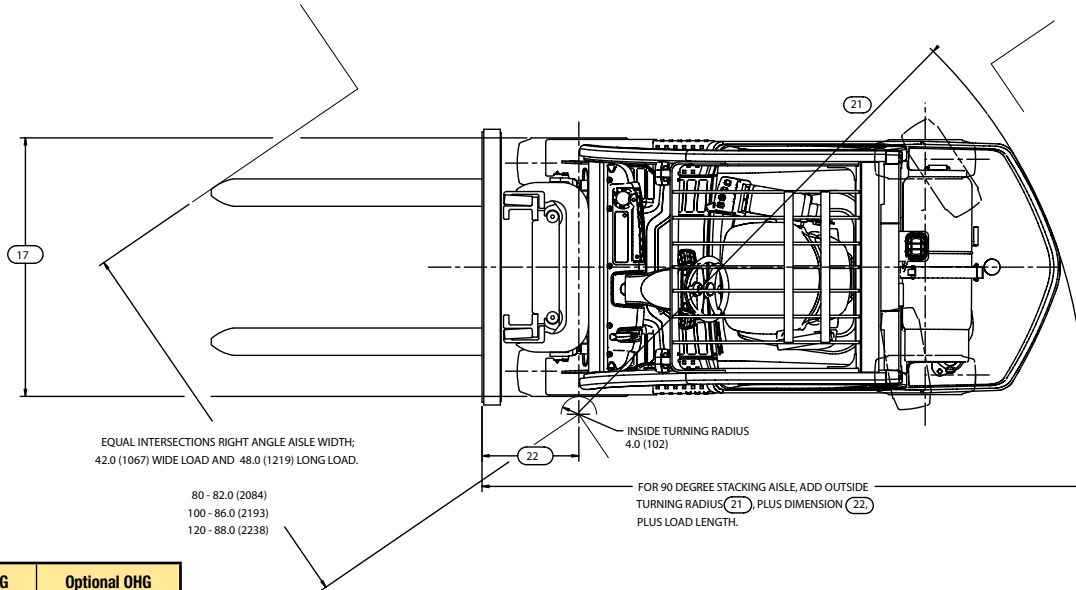

Seat Type	Standard OHG	Optional OHG
Non-Suspension	42.0 (1068)	39.4 (1001)
Semi-Suspension	42.5 (1080)	39.9 (1013)
Full-Suspension	41.8 (1062)	N/A
Swivel Full-Suspension	42.0 (1068)	N/A

TRUCK MODEL	C	D	E	T	X
	in. (mm)	percent	degrees	in. (mm)	in. (mm)
S100FT	20.3 (517)	32%	20	4.6 (116)	28.3 (718)
S120FT	24.0 (609)	32%	21	4.6 (116)	28.3 (718)
S120FTS	17.6 (447)	37%	21	5.9 (151)	28.3 (718)

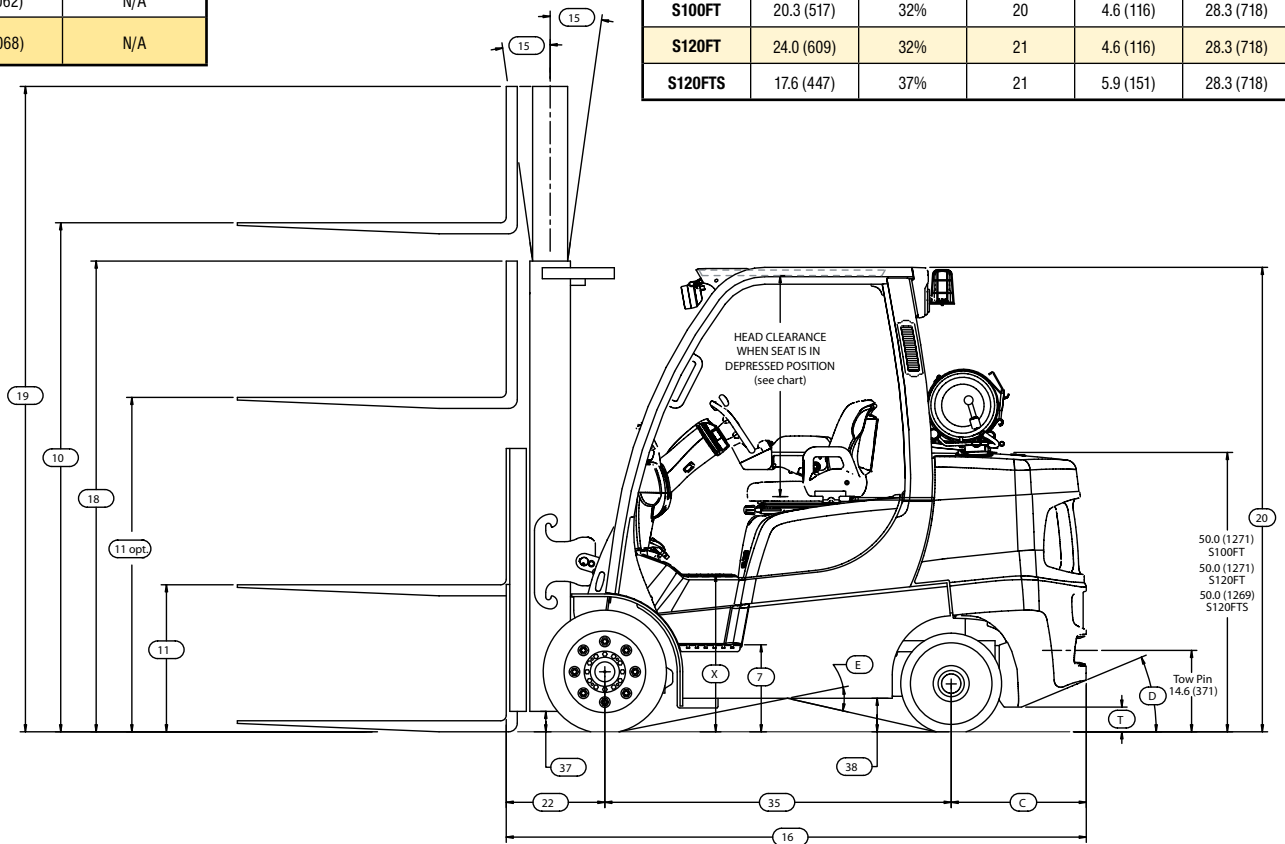

Circled dimensions correspond to the line numbers on the tabulated chart inside the Technical Guide. Dimensions are in inches (millimeters).

CERTIFICATION: These Hyster lift trucks meet design specifications of Part II ANSI B56.1-1969, as required by OSHA Section 1910.178(a)(2) and also comply with Part III ANSI B56.1-revision in effect at time of manufacture. Certification of compliance with the applicable ANSI standards appears on the lift truck.

† NOTE: Performance specifications / ratings are for truck equipped as described under Standard Equipment in this Technical Guide. Performance specifications are affected by the condition of the vehicle and how it is equipped, as well as by the nature and condition of the operating area. Specifications are subject to change and the proposed application should be discussed with your authorized Hyster Company Dealer.

†† Limited by traction. For further information on this dimension, please contact your local Hyster dealer.

S100FT SPECIFICATIONS

GENERAL	1	Manufacturer Name		Hyster Company	Hyster Company	Hyster Company	
	2	Model		S100FT	S100FT	S100FT	
		Manufacturer Designation		Fortis®	Fortis® Advance	Fortis® Advance+	
		Transmission		Electronic Powershift	DuraMatch™ / DuraMatch™ 2	DuraMatch™ Plus 2	
	3	Rated Capacity	lb. (kg)	10,000 (4545)	10,000 (4545)	10,000 (4545)	
	4	Load Center, Distance	in. (mm)	24 (610)	24 (610)	24 (610)	
	5	Engine / Power Type - Gasoline, LPG, Diesel		GM 4.3L / LP	GM 4.3L / LP	GM 4.3L / LP	
	6	Operator Type		Sit-Down Rider	Sit-Down Rider	Sit-Down Rider	
	7	Step Height	in. (mm)	15.6 (396)	15.6 (396)	15.6 (396)	
	8	Tire Type - Cushion, Solid, Pneumatic		Cushion	Cushion	Cushion	
DIMENSIONS	9	Wheels, Number - Front / Rear		2x / 2	2x / 2	2x / 2	
	10	Lift Height, Top of Fork (TOF)	in. (mm)	110 (2 800)	110 (2 800)	110 (2 800)	
	11	Lift Heights, Std. Limited Free Lift (LFL) with LBR (TOF)	in. (mm)	6 (160)	6 (160)	6 (160)	
		Lift Heights, Optional Full Free Lift (FFL) with LBR (TOF)	in. (mm)	35 (907)	35 (907)	35 (907)	
	12	Standard Carriage Width	in. (mm)	42.0 (1 067)	42.0 (1 067)	42.0 (1 067)	
	13	Forks, Thickness x Width x Length	in.	2.0 X 6.0 X 48.0	2.0 X 6.0 X 48.0	2.0 X 6.0 X 48.0	
		Forks, Thickness x Width x Length	(mm)	(50 X 150 X 1 219)	(50 X 150 X 1 219)	(50 X 150 X 1 219)	
	14	Fork Spread, Outside Dimensions	in. (mm)	38.3 (972)	38.3 (972)	38.3 (972)	
	15	Mast Tilt Angles, Forward / Backward	Degrees °	5F / 6B	5F / 6B	5F / 6B	
	16	Length To Face of Forks	in. (mm)	109.0 (2 769)	109.0 (2 769)	109.0 (2 769)	
	17	Overall Width, Standard Tread	in. (mm)	52.0 (1 320)	52.0 (1 320)	52.0 (1 320)	
		Overall Width, Wide Tread	in. (mm)	55.9 (1 420)	55.9 (1 420)	55.9 (1 420)	
	18	Height, Standard Mast - Lowered	in. (mm)	85 (2 138)	85 (2 138)	85 (2 138)	
	19	Height, Standard Mast - Extended with LBR	in. (mm)	159 (4 031)	159 (4 031)	159 (4 031)	
		Height, Standard Mast - Extended without LBR	in. (mm)	144 (3 657)	144 (3 657)	144 (3 657)	
	20	Height, Standard Overhead Guard	in. (mm)	86 (2 175)	86 (2 175)	86 (2 175)	
		Height, Optional Overhead Guard	in. (mm)	83 (2 108)	83 (2 108)	83 (2 108)	
	21	Turning Radius, Minimum Outside (OTR)	in. (mm)	96.3 (2 447)	96.3 (2 447)	96.3 (2 447)	
	22	Length, Center of Wheel to Face of Forks	in. (mm)	18.2 (462)	18.2 (462)	18.2 (462)	
	23	Aisle Width, Right Angle Stack (Add Length of Load)	in. (mm)	114.5 (2 909)	114.5 (2 909)	114.5 (2 909)	
	24	Equal Aisle, 90-Degree Intersecting Aisle	in. (mm)	86.3 (2 193)	86.3 (2 193)	86.3 (2 193)	
	PERFORMANCE 1	25	Travel Speed, Standard Transmission RL/NL	mph (km / h)	10.7 (17.2) / 10.4 (16.7)	10.7 (17.2) / 10.4 (16.7)	—
			Travel Speed, 2-Speed, Std. Trans. RL/NL	mph (km / h)	—	12.5 (20.1) / 12.1 (19.5)	12.5 (20.1) / 12.1 (19.5)
		26	Lift Speed, Standard 2-Stage LFL RL/NL	ft. / min (m / s)	110.2 (.56) / 112.2 (.57)	110.2 (.56) / 112.2 (.57)	110.2 (.56) / 112.2 (.57)
		Lift Speed, Optional 2-Stage FFL RL/NL	ft. / min (m / s)	102.4 (.52) / 106.3 (.54)	102.4 (.52) / 106.3 (.54)	102.4 (.52) / 106.3 (.54)	
		Lift Speed, Optional 3-Stage FFL RL/NL	ft. / min (m / s)	106.3 (.54) / 108.3 (.55)	106.3 (.54) / 108.3 (.55)	106.3 (.54) / 108.3 (.55)	
27		Lowering Speed, Standard 2-Stage LFL RL/NL	ft. / min (m / s)	100.4 (.51) / 82.7 (.42)	100.4 (.51) / 82.7 (.42)	100.4 (.51) / 82.7 (.42)	
		Lowering Speed, Optional 2-Stage FFL RL/NL	ft. / min (m / s)	88.6 (.45) / 63.0 (.32)	88.6 (.45) / 63.0 (.32)	88.6 (.45) / 63.0 (.32)	
		Lowering Speed, Optional 3-Stage FFL RL/NL	ft. / min (m / s)	92.5 (.47) / 76.8 (.39)	92.5 (.47) / 76.8 (.39)	92.5 (.47) / 76.8 (.39)	
28		Drawbar Pull, Maximum RL/NL††	lb. (kg)	6,751 (3 062) / 3,997 (1 813)	6,751 (3 062) / 3,997 (1 813)	—	
		Drawbar Pull, 2-Speed, Maximum RL/NL††	lb. (kg)	—	7,000 (3 175) / 3,997 (1 813)	7,000 (3 175) / 3,997 (1 813)	
		Drawbar Pull @ 1 mph RL/NL††	lb. (kg)	6,010 (2 726) / 3,997 (1 813)	6,010 (2 726) / 3,997 (1 813)	—	
		Drawbar Pull, 2-Speed, @ 1 mph RL/NL††	lb. (kg)	—	6,876 (3 119) / 3,997 (1 813)	7,000 (3 175) / 3,997 (1 813)	
		Drawbar Pull @ 3 mph RL/NL††	lb. (kg)	4,500 (2 041) / 3,997 (1 813)	4,500 (2 041) / 3,997 (1 813)	—	
		Drawbar Pull, 2-Speed, @ 3 mph RL/NL††	lb. (kg)	—	5,025 (2 279) / 3,997 (1 813)	5,600 (2 540) / 3,997 (1 813)	
29		Gradeability @ 1 mph RL/NL††	Percent %	23.7 / 25.7	23.7 / 25.7	—	
		Gradeability, 2-Speed, @ 1 mph RL/NL††	Percent %	—	27.4 / 25.7	27.9 / 25.7	
		Gradeability @ 3 mph RL/NL††	Percent %	17.3 / 24.9	17.3 / 24.9	—	
		Gradeability, 2-Speed, @ 3 mph RL/NL††	Percent %	—	19.3 / 24.9	21.5 / 24.9	
WT.	31	Weight, Standard Truck (2-Stage LFL) NL	lb. (kg.)	16,023 (7 268)	16,023 (7 268)	16,023 (7 268)	
		Weight, Standard Truck (2-Stage LFL) RL	lb. (kg.)	26,023 (12 268)	21,078 (9 932)	21,078 (9 932)	
	32	Axle Loading, Static Front / Rear NL	lb. (kg.)	7,116 (3 228) / 8,904 (4 039)	7,116 (3 228) / 8,904 (4 039)	7,116 (3 228) / 8,904 (4 039)	
		Axle Loading, Static Front / Rear RL	lb. (kg.)	23,349 (10 591) / 2,531 (1 148)	23,349 (10 591) / 2,531 (1 148)	23,349 (10 591) / 2,531 (1 148)	
TIRES & WHEELS	33	Tire Size, Front		22 X 12 X 16	22 X 12 X 16	22 X 12 X 16	
	34	Tire Size, Rear		18 X 8 X 12.2	18 X 8 X 12.2	18 X 8 X 12.2	
	35	Wheelbase	in. (mm)	70.5 (1 790)	70.5 (1 790)	70.5 (1 790)	
	37	Ground Clearance, Lowest Point NL (with RL less 6mm)	in. (mm)	4.6 (118)	4.6 (118)	4.6 (118)	
	38	Ground Clearance, Center of Wheelbase NL	in. (mm)	6.1 (156)	6.1 (156)	6.1 (156)	
	39	Brakes Service - Method of Control / Operation		Foot / Hydraulic	Foot / Hydraulic	Foot / Hydraulic	
	40	Brakes Park - Method of Control / Operation		Hand / Mechanical	Hand / Mechanical	Hand / Mechanical	
	POWERTRAIN	41	Battery Type		Maintenance Free	Maintenance Free	Maintenance Free
42		Volts / Cold Cranking Amps	v / cca	12 / 475	12 / 475	12 / 475	
43		Engine, Manufacturer		GM	GM	GM	
44		Permanent Output @ 2400 rpm	hp	98	98	98	
45		Torque @ rated RPM	ft Lbs. (kg / m)	210 (285)@ 2400 RPM	210 (285)@ 2400 RPM	210 (285)@ 2400 RPM	
46		Number of Cylinders / Displacement	No. cc (ci)	6 / 4302 (262)	6 / 4302 (262)	6 / 4302 (262)	
47		Transmission Type, Standard		Electronic Powershift	DuraMatch™ / DuraMatch™ 2	DuraMatch™ Plus2	
		Standard Speeds Forward / Reverse		1-1	1-1 / 2-1	2-1	
51		Auxiliary Hydraulic Pressure Relief for Attachments	PSI (bar)	2250 (155)	2250 (155)	2250 (155)	

S120FT SPECIFICATIONS

			Hyster Company	Hyster Company	Hyster Company	
GENERAL	1	Manufacturer Name	Hyster Company	Hyster Company	Hyster Company	
	2	Model	S120FT	S120FT	S120FT	
		Manufacturer Designation	Fortis®	Fortis® Advance	Fortis® Advance+	
		Transmission	Electronic Powershift	DuraMatch™ / DuraMatch™ 2	DuraMatch™ Plus 2	
	3	Rated Capacity	lb. (kg)	12,000 (5454)	12,000 (5454)	12,000 (5454)
	4	Load Center, Distance	in. (mm)	24 (610)	24 (610)	24 (610)
	5	Engine / Power Type - Gasoline, LPG, Diesel		GM 4.3L / LP	GM 4.3L / LP	GM 4.3L / LP
	6	Operator Type		Sit-Down Rider	Sit-Down Rider	Sit-Down Rider
	7	Step Height	in. (mm)	15.6 (396)	15.6 (396)	15.6 (396)
	8	Tire Type - Cushion, Solid, Pneumatic		Cushion	Cushion	Cushion
DIMENSIONS	9	Wheels, Number - Front / Rear		2x / 2	2x / 2	
	10	Lift Height, Top of Fork (TOF)	in. (mm)	110 (2 800)	110 (2 800)	110 (2 800)
	11	Lift Heights, Std. Limited Free Lift (LFL) with LBR (TOF)	in. (mm)	6 (160)	6 (160)	6 (160)
		Lift Heights, Optional Full Free Lift (FFL) with LBR (TOF)	in. (mm)	35 (907)	35 (907)	35 (907)
	12	Standard Carriage Width	in. (mm)	42.0 (1 067)	42.0 (1 067)	42.0 (1 067)
	13	Forks, Thickness x Width x Length	in.	2.5 X 6.0 X 48.0	2.5 X 6.0 X 48.0	2.5 X 6.0 X 48.0
		Forks, Thickness x Width x Length	(mm)	(60 X 150 X 1 219)	(60 X 150 X 1 219)	(60 X 150 X 1 219)
	14	Fork Spread, Outside Dimensions	in. (mm)	38.3 (972)	38.3 (972)	38.3 (972)
	15	Mast Tilt Angles, Forward / Backward	Degrees °	5F / 6B	5F / 6B	5F / 6B
	16	Length To Face of Forks	in. (mm)	112.7 (2 862)	112.7 (2 862)	112.7 (2 862)
	17	Overall Width, Standard Tread	in. (mm)	52.0 (1 320)	52.0 (1 320)	52.0 (1 320)
		Overall Width, Wide Tread	in. (mm)	55.9 (1 420)	55.9 (1 420)	55.9 (1 420)
	18	Height, Standard Mast - Lowered	in. (mm)	85 (2 138)	85 (2 138)	85 (2 138)
	19	Height, Standard Mast - Extended with LBR	in. (mm)	159 (4 031)	159 (4 031)	159 (4 031)
		Height, Standard Mast - Extended without LBR	in. (mm)	144 (3 657)	144 (3 657)	144 (3 657)
	20	Height, Standard Overhead Guard	in. (mm)	86 (2 175)	86 (2 175)	86 (2 175)
		Height, Optional Overhead Guard	in. (mm)	83 (2 108)	83 (2 108)	83 (2 108)
	21	Turning Radius, Minimum Outside (OTR)	in. (mm)	99.8 (2 534)	99.8 (2 534)	99.8 (2 534)
	22	Length, Center of Wheel to Face of Forks	in. (mm)	18.2 (462)	18.2 (462)	18.2 (462)
	23	Aisle Width, Right Angle Stack (Add Length of Load)	in. (mm)	118.0 (2 996)	118.0 (2 996)	118.0 (2 996)
	24	Equal Aisle, 90-Degree Intersecting Aisle	in. (mm)	88.1 (2 238)	88.1 (2 238)	88.1 (2 238)
	25	Travel Speed, Standard Transmission RL/NL	mph (km / h)	10.7 (17.2) / 10.4 (16.7)	10.7 (17.2) / 10.4 (16.7)	—
		Travel Speed, 2-Speed, Std. Trans. RL/NL	mph (km / h)	—	12.5 (20.1) / 12.1 (19.5)	12.5 (20.1) / 12.1 (19.5)
	26	Lift Speed, Standard 2-Stage LFL RL/NL	ft. / min (m / s)	110.2 (.56) / 112.2 (.57)	110.2 (.56) / 112.2 (.57)	110.2 (.56) / 112.2 (.57)
		Lift Speed, Optional 2-Stage FFL RL/NL	ft. / min (m / s)	102.4 (.52) / 106.3 (.54)	102.4 (.52) / 106.3 (.54)	102.4 (.52) / 106.3 (.54)
	Lift Speed, Optional 3-Stage FFL RL/NL	ft. / min (m / s)	106.3 (.54) / 108.3 (.55)	106.3 (.54) / 108.3 (.55)	106.3 (.54) / 108.3 (.55)	
27	Lowering Speed, Standard 2-Stage LFL RL/NL	ft. / min (m / s)	100.4 (.51) / 82.7 (.42)	100.4 (.51) / 82.7 (.42)	100.4 (.51) / 82.7 (.42)	
	Lowering Speed, Optional 2-Stage FFL RL/NL	ft. / min (m / s)	92.5 (.47) / 63.0 (.32)	92.5 (.47) / 63.0 (.32)	92.5 (.47) / 63.0 (.32)	
	Lowering Speed, Optional 3-Stage FFL RL/NL	ft. / min (m / s)	92.5 (.47) / 76.8 (.39)	92.5 (.47) / 76.8 (.39)	92.5 (.47) / 76.8 (.39)	
28	Drawbar Pull, Maximum RL/NL††	lb. (kg)	6,737 (3 056) / 3,786 (1 717)	6,737 (3 056) / 3,786 (1 717)	—	
	Drawbar Pull, 2-Speed, Maximum RL/NL††	lb. (kg)	—	7,000 (3 175) / 3,786 (1 717)	7,000 (3 175) / 3,786 (1 717)	
	Drawbar Pull @ 1 mph RL/NL††	lb. (kg)	5,993 (2 718) / 3,786 (1 717)	5,993 (2 718) / 3,786 (1 717)	—	
	Drawbar Pull, 2-Speed, @ 1 mph RL/NL††	lb. (kg)	—	6,861 (3 112) / 3,786 (1 717)	7,000 (3 175) / 3,786 (1 717)	
	Drawbar Pull @ 3 mph RL/NL††	lb. (kg)	4,300 (1 950) / 3,786 (1 717)	4,300 (1 950) / 3,786 (1 717)	—	
	Drawbar Pull, 2-Speed, @ 3 mph RL/NL††	lb. (kg)	—	5,000 (2 268) / 3,786 (1 717)	5,500 (2 495) / 3,786 (1 717)	
29	Gradeability @ 1 mph RL/NL††	Percent %	20.8 / 22.2	20.8 / 22.2	—	
	Gradeability, 2-Speed, @ 1 mph RL/NL††	Percent %	—	23.9 / 22.2	24.8 / 22.2	
	Gradeability @ 3 mph RL/NL††	Percent %	14.6 / 21.7	14.6 / 21.7	—	
	Gradeability, 2-Speed, @ 3 mph RL/NL††	Percent %	—	17.0 / 21.7	18.7 / 21.7	
31	Weight, Standard Truck (2-Stage LFL) NL	lb. (kg.)	17,383 (7 885)	17,383 (7 885)	17,383 (7 885)	
	Weight, Standard Truck (2-Stage LFL) RL	lb. (kg.)	26,023 (12 268)	21,078 (9 932)	21,078 (9 932)	
32	Axle Loading, Static Front / Rear NL	lb. (kg.)	6,773 (3 072) / 10,611 (4 813)	6,773 (3 072) / 10,611 (4 813)	6,773 (3 072) / 10,611 (4 813)	
	Axle Loading, Static Front / Rear RL	lb. (kg.)	25,957 (11 774) / 3,426 (1 554)	25,957 (11 774) / 3,426 (1 554)	25,957 (11 774) / 3,426 (1 554)	
TIRES & WHEELS	33	Tire Size, Front		22 X 12 X 16	22 X 12 X 16	
	34	Tire Size, Rear		18 X 8 X 12.2	18 X 8 X 12.2	
	35	Wheelbase	in. (mm)	70.5 (1 790)	70.5 (1 790)	70.5 (1 790)
	37	Ground Clearance, Lowest Point NL (with RL less 6mm)	in. (mm)	4.6 (118)	4.6 (118)	4.6 (118)
	38	Ground Clearance, Center of Wheelbase NL	in. (mm)	6.1 (156)	6.1 (156)	6.1 (156)
	39	Brakes Service - Method of Control / Operation		Foot / Hydraulic	Foot / Hydraulic	Foot / Hydraulic
40	Brakes Park - Method of Control / Operation		Hand / Mechanical	Hand / Mechanical	Hand / Mechanical	
POWERTRAIN	41	Battery Type		Maintenance Free	Maintenance Free	
	42	Volts / Cold Cranking Amps	v / cca	12 / 475	12 / 475	12 / 475
	43	Engine, Manufacturer		GM	GM	GM
	44	Permanent Output @ 2400 rpm	hp	98	98	98
	45	Torque @ rated RPM	ft Lbs. (kg / m)	210 (285)@ 2400 RPM	210 (285)@ 2400 RPM	210 (285)@ 2400 RPM
	46	Number of Cylinders / Displacement	No. cc (ci)	6 / 4302 (262)	6 / 4302 (262)	6 / 4302 (262)
	47	Transmission Type, Standard		Electronic Powershift	DuraMatch™ / DuraMatch™ 2	DuraMatch™ Plus2
		Standard Speeds Forward / Reverse		1-1	1-1 / 2-1	2-1
51	Auxiliary Hydraulic Pressure Relief for Attachments	PSI (bar)	2250 (155)	2250 (155)	2250 (155)	

S120FTS SPECIFICATIONS

		Hyster Company	Hyster Company	Hyster Company	
GENERAL	1	Manufacturer Name	Hyster Company	Hyster Company	
	2	Model	S120FTS	S120FTS	
		Manufacturer Designation	Fortis®	Fortis® Advance	
		Transmission	Electronic Powershift	DuraMatch™ / DuraMatch™ 2	
	3	Rated Capacity	12,000 (5454)	12,000 (5454)	
	4	Load Center, Distance	24 (610)	24 (610)	
	5	Engine / Power Type - Gasoline, LPG, Diesel	GM 4.3L / LP	GM 4.3L / LP	
	6	Operator Type	Sit-Down Rider	Sit-Down Rider	
	7	Step Height	15.6 (396)	15.6 (396)	
	8	Tire Type - Cushion, Solid, Pneumatic	Cushion	Cushion	
DIMENSIONS	9	Wheels, Number - Front / Rear	2x / 2	2x / 2	
	10	Lift Height, Top of Fork (TOF)	110 (2 800)	110 (2 800)	
	11	Lift Heights, Std. Limited Free Lift (LFL) with LBR (TOF)	6 (160)	6 (160)	
		Lift Heights, Optional Full Free Lift (FFL) with LBR (TOF)	35 (907)	35 (907)	
	12	Standard Carriage Width	42.0 (1 067)	42.0 (1 067)	
	13	Forks, Thickness x Width x Length	2.5 X 6.0 X 48.0	2.5 X 6.0 X 48.0	
		Forks, Thickness x Width x Length	(60 X 150 X 1 219)	(60 X 150 X 1 219)	
	14	Fork Spread, Outside Dimensions	38.3 (972)	38.3 (972)	
	15	Mast Tilt Angles, Forward / Backward	5F / 6B	5F / 6B	
	16	Length To Face of Forks	106.3 (2 699)	106.3 (2 699)	
	17	Overall Width, Standard Tread	52.0 (1 320)	52.0 (1 320)	
		Overall Width, Wide Tread	55.9 (1 420)	55.9 (1 420)	
	18	Height, Standard Mast - Lowered	85 (2 138)	85 (2 138)	
	19	Height, Standard Mast - Extended with LBR	159 (4 031)	159 (4 031)	
		Height, Standard Mast - Extended without LBR	144 (3 657)	144 (3 657)	
	20	Height, Standard Overhead Guard	86 (2 175)	86 (2 175)	
		Height, Optional Overhead Guard	83 (2 108)	83 (2 108)	
	21	Turning Radius, Minimum Outside (OTR)	93.5 (2 375)	93.5 (2 375)	
	22	Length, Center of Wheel to Face of Forks	18.2 (462)	18.2 (462)	
	23	Aisle Width, Right Angle Stack (Add Length of Load)	115.6 (2 937)	115.6 (2 937)	
	24	Equal Aisle, 90-Degree Intersecting Aisle	86.3 (2 192)	86.3 (2 192)	
	PERFORMANCE †	25	Travel Speed, Standard Transmission RL/NL	10.7 (17.2) / 10.4 (16.7)	10.7 (17.2) / 10.4 (16.7)
			Travel Speed, 2-Speed, Std. Trans. RL/NL	—	12.5 (20.1) / 12.1 (19.5)
		26	Lift Speed, Standard 2-Stage LFL RL/NL	110.2 (.56) / 112.2 (.57)	110.2 (.56) / 112.2 (.57)
			Lift Speed, Optional 2-Stage FFL RL/NL	102.4 (.52) / 106.3 (.54)	102.4 (.52) / 106.3 (.54)
		Lift Speed, Optional 3-Stage FFL RL/NL	106.3 (.54) / 108.3 (.55)	106.3 (.54) / 108.3 (.55)	
27		Lowering Speed, Standard 2-Stage LFL RL/NL	100.4 (.51) / 82.7 (.42)	100.4 (.51) / 82.7 (.42)	
		Lowering Speed, Optional 2-Stage FFL RL/NL	92.5 (.47) / 63.0 (.32)	92.5 (.47) / 63.0 (.32)	
		Lowering Speed, Optional 3-Stage FFL RL/NL	92.5 (.47) / 76.8 (.39)	92.5 (.47) / 76.8 (.39)	
28		Drawbar Pull, Maximum RL/NL††	6,737 (3 056) / 3,786 (1 717)	6,737 (3 056) / 3,786 (1 717)	
		Drawbar Pull, 2-Speed, Maximum RL/NL††	—	7,000 (3 175) / 3,786 (1 717)	
		Drawbar Pull @ 1 mph RL/NL††	5,993 (2 718) / 3,786 (1 717)	5,993 (2 718) / 3,786 (1 717)	
		Drawbar Pull, 2-Speed, @ 1 mph RL/NL††	—	6,861 (3 112) / 3,786 (1 717)	
		Drawbar Pull @ 3 mph RL/NL††	4,300 (1 950) / 3,786 (1 717)	4,300 (1 950) / 3,786 (1 717)	
		Drawbar Pull, 2-Speed, @ 3 mph RL/NL††	—	5,000 (2 268) / 3,786 (1 717)	
29		Gradeability @ 1 mph RL/NL††	20.8 / 22.2	20.8 / 22.2	
	Gradeability, 2-Speed, @ 1 mph RL/NL††	—	23.9 / 22.2		
	Gradeability @ 3 mph RL/NL††	14.6 / 21.7	14.6 / 21.7		
	Gradeability, 2-Speed, @ 3 mph RL/NL††	N/A	17.0 / 21.7		
WT.	31	Weight, Standard Truck (2-Stage LFL) NL	17,436 (7 909)	17,436 (7 909)	
		Weight, Standard Truck (2-Stage LFL) RL	29,436 (13 409)	29,436 (13 409)	
	32	Axle Loading, Static Front / Rear NL	7,227 (3 278) / 10,210 (4 631)	7,227 (3 278) / 10,210 (4 631)	
		Axle Loading, Static Front / Rear RL	26,413 (11 981) / 3,023 (1 371)	26,413 (11 981) / 3,023 (1 371)	
TIRES & WHEELS	33	Tire Size, Front	22 X 12 X 16	22 X 12 X 16	
	34	Tire Size, Rear	18 X 8 X 12.2	18 X 8 X 12.2	
	35	Wheelbase	70.5 (1 790)	70.5 (1 790)	
	37	Ground Clearance, Lowest Point NL (with RL less 6mm)	4.6 (118)	4.6 (118)	
	38	Ground Clearance, Center of Wheelbase NL	6.1 (156)	6.1 (156)	
	39	Brakes Service - Method of Control / Operation	Foot / Hydraulic	Foot / Hydraulic	
	40	Brakes Park - Method of Control / Operation	Hand / Mechanical	Hand / Mechanical	
	41	Battery Type	Maintenance Free	Maintenance Free	
	42	Volts / Cold Cranking Amps	12 / 475	12 / 475	
	POWERTRAIN	43	Engine, Manufacturer	GM	GM
44		Permanent Output @ 2400 rpm	98	98	
45		Torque @ rated RPM	210 (285)@ 2400 RPM	210 (285)@ 2400 RPM	
46		Number of Cylinders / Displacement	6 / 4302 (262)	6 / 4302 (262)	
47		Transmission Type, Standard	Electronic Powershift	DuraMatch™ / DuraMatch™ 2	
		Standard Speeds Forward / Reverse	1-1	1-1 / 2-1	
51		Auxiliary Hydraulic Pressure Relief for Attachments	2250 (155)	2250 (155)	

S80-100FT BCS DIMENSIONS

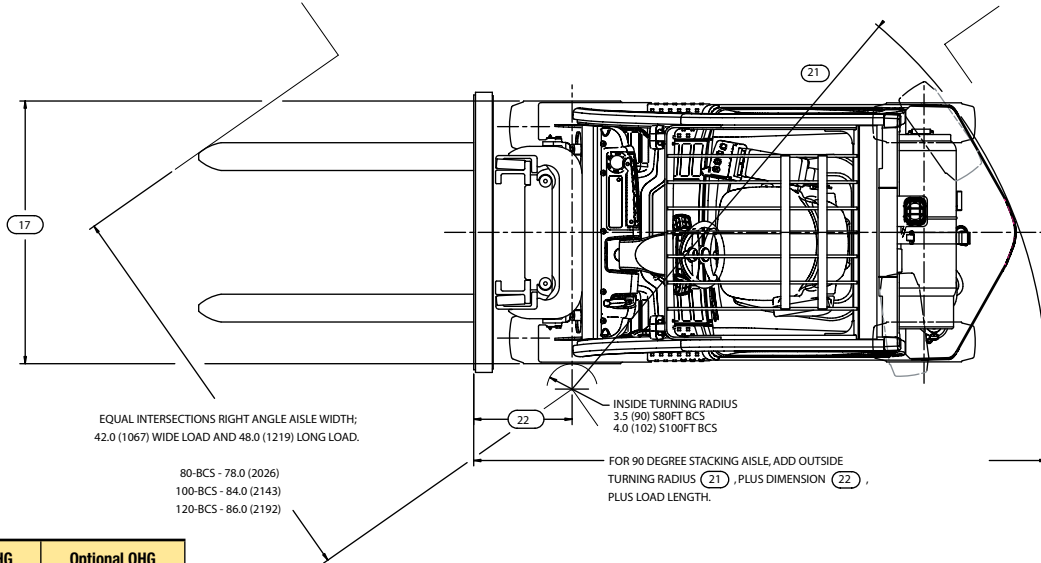

Seat Type	Standard OHG	Optional OHG
Non-Suspension	42.0 (1068)	39.4 (1001)
Semi-Suspension	42.5 (1080)	39.9 (1013)
Full-Suspension	41.8 (1062)	N/A
Swivel Full-Suspension	42.0 (1068)	N/A

TRUCK MODEL	C	D	E	T	X
	in. (mm)	percent	degrees	in. (mm)	in. (mm)
S80FT BCS	16.1 (410)	44%	25.2	4.4 (112)	28.1 (714)
S100FT BCS	21.6 (549)	42%	22.2	5.9 (151)	28.3 (718)

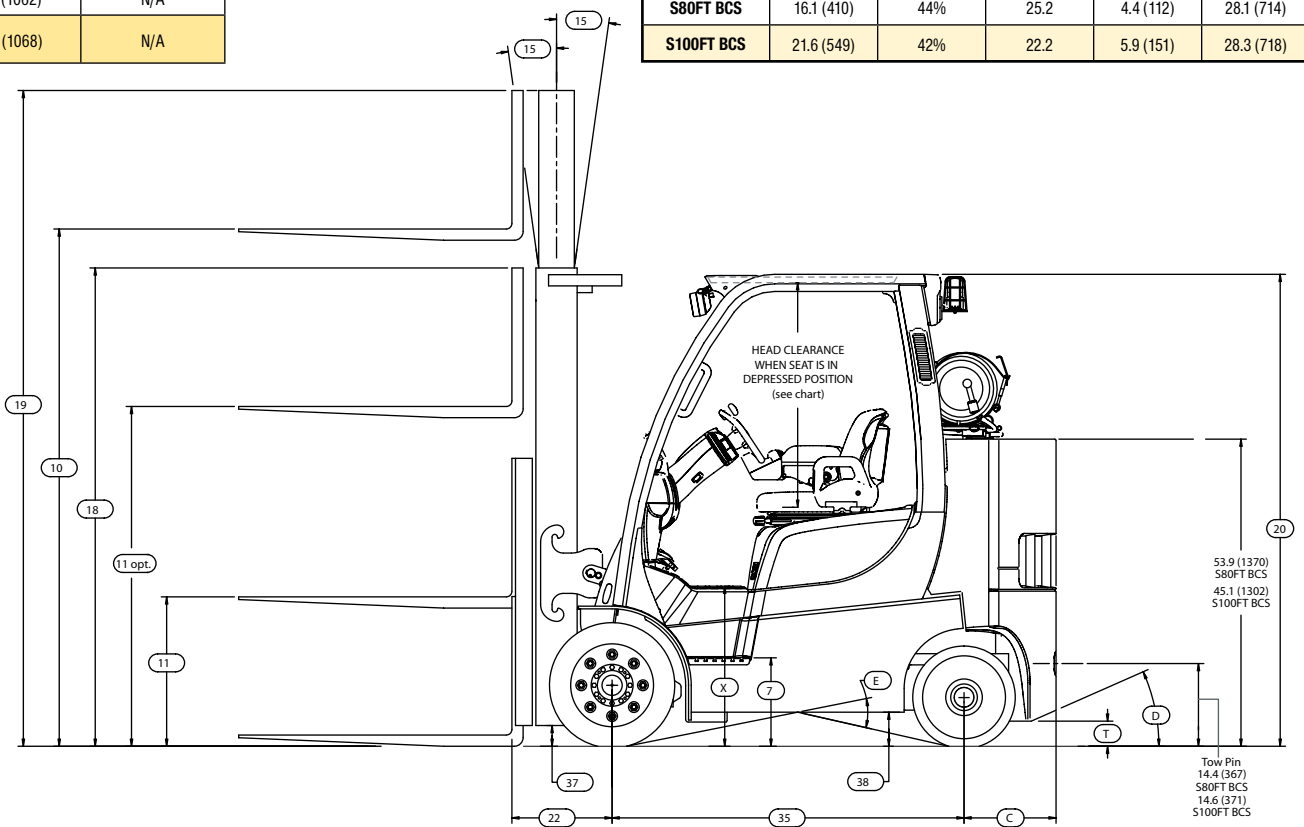

Circled dimensions correspond to the line numbers on the tabulated chart inside the Technical Guide. Dimensions are in inches (millimeters).

CERTIFICATION: These Hyster lift trucks meet design specifications of Part II ANSI B56.1-1969, as required by OSHA Section 1910.178(a)(2) and also comply with Part III ANSI B56.1-revision in effect at time of manufacture. Certification of compliance with the applicable ANSI standards appears on the lift truck.

† NOTE: Performance specifications / ratings are for truck equipped as described under Standard Equipment in this Technical Guide. Performance specifications are affected by the condition of the vehicle and how it is equipped, as well as by the nature and condition of the operating area. Specifications are subject to change and the proposed application should be discussed with your authorized Hyster Company Dealer.

†† Limited by traction. For further information on this dimension, please contact your local Hyster dealer.

S120FT PRS DIMENSIONS

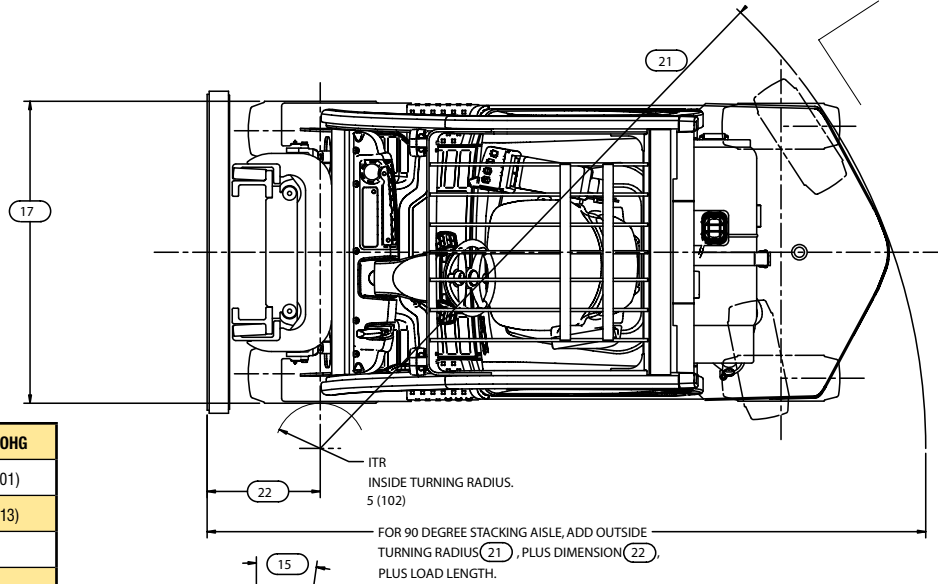

Seat Type	Standard OHG	Optional OHG
Non-Suspension	42.0 (1068)	39.4 (1001)
Semi-Suspension	42.5 (1080)	39.9 (1013)
Full-Suspension	41.8 (1062)	N/A
Swivel Full-Suspension	42.0 (1068)	N/A

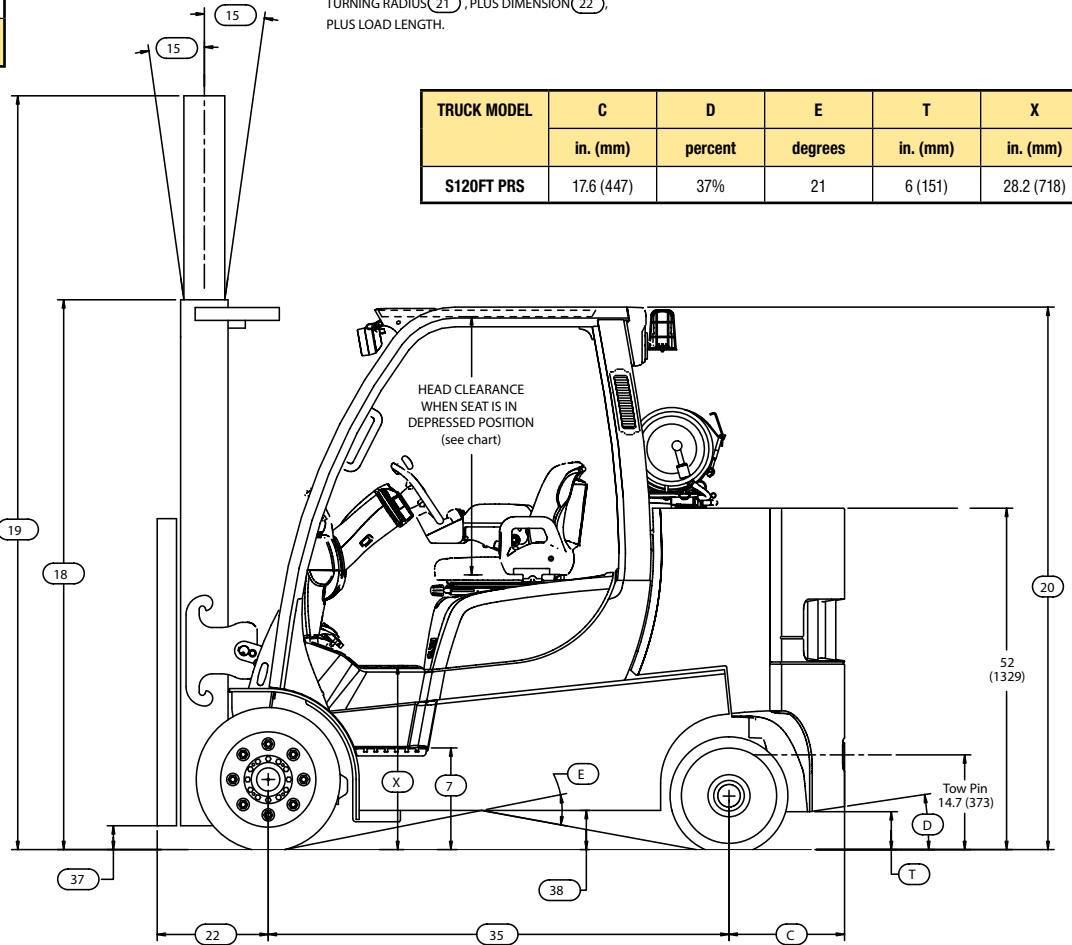

TRUCK MODEL	C	D	E	T	X
	in. (mm)	percent	degrees	in. (mm)	in. (mm)
S120FT PRS	17.6 (447)	37%	21	6 (151)	28.2 (718)

Circled dimensions correspond to the line numbers on the tabulated chart inside the Technical Guide. Dimensions are in inches (millimeters).

CERTIFICATION: These Hyster lift trucks meet design specifications of Part II ANSI B56.1-1969, as required by OSHA Section 1910.178(a)(2) and also comply with Part III ANSI B56.1-revision in effect at time of manufacture. Certification of compliance with the applicable ANSI standards appears on the lift truck.

† NOTE: Performance specifications / ratings are for truck equipped as described under Standard Equipment in this Technical Guide. Performance specifications are affected by the condition of the vehicle and how it is equipped, as well as by the nature and condition of the operating area. Specifications are subject to change and the proposed application should be discussed with your authorized Hyster Company Dealer.

†† Limited by traction. For further information on this dimension, please contact your local Hyster dealer.

S120FT PRS SPECIFICATIONS

GENERAL	1	Manufacturer Name		Hyster Company	Hyster Company	Hyster Company
		2	Model		S120FT PRS	S120FT PRS
	3	Manufacturer Designation		Fortis®	Fortis® Advance	Fortis® Advance+
		4	Transmission		Electronic Powershift	DuraMatch™ / DuraMatch™ 2
	5	Rated Capacity	lb. (kg)	Varies According To Attachment Fitted	Varies According To Attachment Fitted	Varies According To Attachment Fitted
		6	Load Center, Distance	in. (mm)	24 (610)	24 (610)
	7	Engine / Power Type - Gasoline, LPG, Diesel		GM 4.3L / LP	GM 4.3L / LP	GM 4.3L / LP
		8	Operator Type		Sit-Down Rider	Sit-Down Rider
	9	Step Height	in. (mm)	15.6 (396)	15.6 (396)	15.6 (396)
		10	Tire Type - Cushion, Solid, Pneumatic		Cushion	Cushion
	11	Wheels, Number - Front / Rear		2x / 2	2x / 2	2x / 2
		12	Lift Height, Top of Fork (TOF)	in. (mm)	N/A	N/A
	13	Lift Heights, Std. Limited Free Lift (LFL) with LBR (TOF)	in. (mm)	N/A	N/A	N/A
		14	Lift Heights, Optional Full Free Lift (FFL) with LBR (TOF)	in. (mm)	N/A	N/A
	15	Standard Carriage Width	in. (mm)	42.0 (1 067)	42.0 (1 067)	42.0 (1 067)
		16	Forks, Thickness x Width x Length	in.	No Forks	No Forks
	17	Forks, Thickness x Width x Length	(mm)	No Forks	No Forks	No Forks
		18	Fork Spread, Outside Dimensions	in. (mm)	38.3 (972)	38.3 (972)
	19	Mast Tilt Angles, Forward / Backward	Degrees °	5F / 6B	5F / 6B	5F / 6B
		20	Length To Face of Forks	in. (mm)	N/A	N/A
	21	Overall Width, Standard Tread	in. (mm)	52.0 (1 320)	52.0 (1 320)	52.0 (1 320)
		22	Overall Width, Wide Tread	in. (mm)	55.9 (1 420)	55.9 (1 420)
	23	Height, Standard Mast - Lowered	in. (mm)	85 (2 138)	85 (2 138)	85 (2 138)
		24	Height, Standard Mast - Extended with LBR	in. (mm)	159 (4 031)	159 (4 031)
	25	Height, Standard Mast - Extended without LBR	in. (mm)	144 (3 657)	144 (3 657)	144 (3 657)
		26	Height, Standard Overhead Guard	in. (mm)	86 (2 175)	86 (2 175)
	27	Height, Optional Overhead Guard	in. (mm)	83 (2 108)	83 (2 108)	83 (2 108)
		28	Turning Radius, Minimum Outside (OTR)	in. (mm)	93.5 (2 375)	93.5 (2 375)
	29	Length, Center of Wheel to Face of Forks	in. (mm)	N/A	N/A	N/A
		30	Aisle Width, Right Angle Stack (Add Length of Load)	in. (mm)	115.6 (2 937)	115.6 (2 937)
	31	Equal Aisle, 90-Degree Intersecting Aisle	in. (mm)	86.3 (2 192)	86.3 (2 192)	86.3 (2 192)
		32	Travel Speed, Standard Transmission RL/NL	mph (km / h)	10.7 (17.2) / 10.4 (16.7)	10.7 (17.2) / 10.4 (16.7)
	33	Travel Speed, 2-Speed, Std. Trans. RL/NL	mph (km / h)	-	12.5 (20.1) / 12.1 (19.5)	12.5 (20.1) / 12.1 (19.5)
		34	Lift Speed, Standard 2-Stage LFL RL/NL	ft. / min (m / s)	110.2 (.56) / 112.2 (.57)	110.2 (.56) / 112.2 (.57)
	35	Lift Speed, Optional 2-Stage FFL RL/NL	ft. / min (m / s)	102.4 (.52) / 106.3 (.54)	102.4 (.52) / 106.3 (.54)	102.4 (.52) / 106.3 (.54)
		36	Lift Speed, Optional 3-Stage FFL RL/NL	ft. / min (m / s)	106.3 (.54) / 108.3 (.55)	106.3 (.54) / 108.3 (.55)
	37	Lowering Speed, Standard 2-Stage LFL RL/NL	ft. / min (m / s)	100.4 (.51) / 82.7 (.42)	100.4 (.51) / 82.7 (.42)	100.4 (.51) / 82.7 (.42)
		38	Lowering Speed, Optional 2-Stage FFL RL/NL	ft. / min (m / s)	92.5 (.47) / 63.0 (.32)	92.5 (.47) / 63.0 (.32)
	39	Lowering Speed, Optional 3-Stage FFL RL/NL	ft. / min (m / s)	92.5 (.47) / 76.8 (.39)	92.5 (.47) / 76.8 (.39)	92.5 (.47) / 76.8 (.39)
		40	Drawbar Pull, Maximum RL/NL††	lb. (kg)	8,714 (3 953) / 4,068 (1 845)	6,714 (3 045) / 4,068 (1 845)
	41	Drawbar Pull, 2-Speed, Maximum RL/NL††	lb. (kg)	-	7,000 (3 175) / 4,068 (1 845)	7,000 (3 175) / 4,068 (1 845)
		42	Drawbar Pull @ 1 mph RL/NL††	lb. (kg)	5,970 (2 708) / 4,068 (1 845)	5,970 (2 708) / 4,068 (1 845)
	43	Drawbar Pull, 2-Speed, @ 1 mph RL/NL††	lb. (kg)	-	6,855 (3 109) / 4,068 (1 845)	7,000 (3 175) / 4,068 (1 845)
		44	Drawbar Pull @ 3 mph RL/NL††	lb. (kg)	4,300 (1 950) / 4,068 (1 845)	4,300 (1 950) / 3,786 (1 717)
	45	Drawbar Pull, 2-Speed, @ 3 mph RL/NL††	lb. (kg)	-	5,000 (2 268) / 4,068 (1 845)	5,200 (2 359) / 4,068 (1 845)
		46	Gradeability @ 1 mph RL/NL††	Percent %	19.8 / 22.2	19.8 / 22.2
	47	Gradeability, 2-Speed, @ 1 mph RL/NL††	Percent %	-	22.9 / 22.2	23.4 / 22.2
		48	Gradeability @ 3 mph RL/NL††	Percent %	14.0 / 21.7	14.0 / 21.7
	49	Gradeability, 2-Speed, @ 3 mph RL/NL††	Percent %	-	16.2 / 21.7	16.9 / 21.7
		50	Weight, Standard Truck (2-Stage LFL) NL	lb. (kg.)	18,686 (8 476)	18,686 (8 476)
	51	Weight, Standard Truck (2-Stage LFL) RL	lb. (kg.)	30,686 (13 976)	30,686 (13 976)	30,686 (13 976)
		52	Axle Loading, Static Front / Rear NL	lb. (kg.)	7,187 (3 260) / 11,499 (5 216)	7,187 (3 260) / 11,499 (5 216)
	53	Axle Loading, Static Front / Rear RL	lb. (kg.)	26,374 (11 963) / 4,312 (1 956)	26,374 (11 963) / 4,312 (1 956)	26,374 (11 963) / 4,312 (1 956)
		54	Tire Size, Front		22 X 12 X 16	22 X 12 X 16
	55	Tire Size, Rear		18 X 8 X 12.2	18 X 8 X 12.2	18 X 8 X 12.2
		56	Wheelbase	in. (mm)	70.5 (1 790)	70.5 (1 790)
	57	Ground Clearance, Lowest Point NL (with RL less 6mm)	in. (mm)	4.6 (118)	4.6 (118)	4.6 (118)
		58	Ground Clearance, Center of Wheelbase NL	in. (mm)	6.1 (156)	6.1 (156)
	59	Brakes Service - Method of Control / Operation		Foot / Hydraulic	Foot / Hydraulic	Foot / Hydraulic
		60	Brakes Park - Method of Control / Operation		Hand / Mechanical	Hand / Mechanical
	61	Battery Type		Maintenance Free	Maintenance Free	Maintenance Free
		62	Volts / Cold Cranking Amps	v / cca	12 / 475	12 / 475
	63	Engine, Manufacturer		GM	GM	GM
		64	Permanent Output @ 2400 rpm	hp	98	98
	65	Torque @ rated RPM	ft Lbs. (kg / m)	210 (285)@ 2400 RPM	210 (285)@ 2400 RPM	210 (285)@ 2400 RPM
		66	Number of Cylinders / Displacement	No. cc (ci)	6 / 4302 (262)	6 / 4302 (262)
	67	Transmission Type, Standard		Electronic Powershift	DuraMatch™ / DuraMatch™ 2	DuraMatch™ Plus2
		68	Standard Speeds Forward / Reverse		1-1	1-1 / 2-1
	69	Auxiliary Hydraulic Pressure Relief for Attachments	PSI (bar)	2250 (155)	2250 (155)	2250 (155)

MAST DIMENSIONS

S80FT/S80FT BCS MAST DIMENSIONS

Maximum Fork Height (TOF) †	Overall Lowered Ht.	Overall Extended Height		Free-Lift (TOF)		Approximate Total Wt. of Standard Equipped Truck	
		w/ Load Backrest	w/o Load Backrest	w/ Load Backrest	w/o Load Backrest	S80FT with NL	S80FT BCS with NL
in. (mm)	in. (mm)	in. (mm)	in. (mm)	in. (mm)	in. (mm)	lbs. (kg)	lbs. (kg)
2-STAGE LIMITED FREE-LIFT (LFL) VISTA® MAST							
120 (3050)	85 (2134)	169 (4284)	149 (3783)	5 (150)	5 (150)	13,078 (5932)	13,521 (6133)
143 (3650)	96 (2434)	193 (4897)	193 (4884)	5 (150)	5 (150)	13,225 (5999)	13,669 (6200)
2-STAGE FULL FREE-LIFT (FFL) VISTA® MAST							
121 (3075)	85 (2134)	170 (4309)	152 (3857)	35 (900)	53 (1352)	13,221 (5997)	13,664 (6198)
3-STAGE FULL FREE-LIFT (FFL) VISTA® MAST							
173 (4415)	85 (2134)	223 (5649)	205 (5197)	35 (900)	53 (1352)	13,759 (6241)	14,202 (6442)
185 (4715)	88 (2234)	235 (5949)	217 (5497)	39 (1000)	57 (1452)	13,834 (6275)	14,277 (6476)
194 (4950)	92 (2334)	244 (6184)	226 (5732)	43 (1100)	61 (1552)	13,909 (6309)	14,352 (6510)
218 (5550)	100 (2534)	268 (6784)	250 (6332)	51 (1300)	68 (1752)	14,061 (6378)	14,504 (6579)

† Lift heights over 171.5" (4356 mm) maximum fork height are considered highlifts and require reduced capacity and restricted back tilt.
 Total approximate weights listed include mast, standard carriage, load backrest extension and 70 lbs. LP tank and tank bracket.
 RL = Rated Load NL = No Load

S100FT/S100FT BCS MAST DIMENSIONS

Maximum Fork Height (TOF) †	Overall Lowered Ht.	Overall Extended Height		Free-Lift (TOF)		Approximate Total Wt. of Standard Equipped Truck	
		w/ Load Backrest	w/o Load Backrest	w/ Load Backrest	w/o Load Backrest	S100FT with NL	S100FT BCS with NL
in. (mm)	in. (mm)	in. (mm)	in. (mm)	in. (mm)	in. (mm)	lbs. (kg)	lbs. (kg)
2-STAGE LIMITED FREE-LIFT (LFL) VISTA® MAST							
110 (2800)	85 (2138)	159 (4031)	144 (3657)	6 (160)	6 (160)	16,023 (7268)	16,625 (7541)
133 (3400)	96 (2438)	183 (4631)	168 (4257)	6 (160)	6 (160)	16,180 (7339)	16,781 (7612)
157 (4000)	108 (2738)	206 (5231)	192 (4857)	6 (160)	6 (160)	16,338 (7411)	16,940 (7684)
2-STAGE FULL FREE-LIFT (FFL) VISTA® MAST							
111 (2825)	85 (2138)	160 (4056)	147 (3731)	35 (907)	48 (1232)	16,124 (7314)	16,726 (7587)
134 (3425)	96 (2438)	184 (4656)	171 (4331)	47 (1207)	60 (1532)	16,228 (7388)	16,889 (7661)
3-STAGE FULL FREE-LIFT (FFL) VISTA® MAST							
163 (4147)	85 (2138)	212 (5378)	200 (5058)	35 (907)	48 (1227)	16,755 (7600)	17,357 (7873)
185 (4700)	92 (2338)	234 (5931)	221 (5611)	43 (1107)	56 (1427)	16,918 (7674)	17,520 (7947)
208 (5300)	100 (2538)	258 (6531)	245 (6211)	51 (1307)	64 (1627)	17,088 (7751)	17,690 (8024)

† Lift heights over 171.5" (4356 mm) maximum fork height are considered highlifts and require reduced capacity and restricted back tilt.
 Total approximate weights listed include mast, standard carriage, load backrest extension and 70 lbs. LP tank and tank bracket.
 RL = Rated Load NL = No Load

S120FT/S120FTS MAST DIMENSIONS							
Maximum Fork Height (TOF) †	Overall Lowered Ht.	Overall Extended Height		Free-Lift (TOF)		Approximate Total Wt. of Standard Equipped Truck	
		w/ Load Backrest	w/o Load Backrest	w/ Load Backrest	w/o Load Backrest	S120FT with NL	S120FTS with NL
in. (mm)	in. (mm)	in. (mm)	in. (mm)	in. (mm)	in. (mm)	lbs. (kg)	lbs. (kg)
2-STAGE LIMITED FREE-LIFT (LFL) VISTA® MAST							
110 (2800)	85 (2138)	159 (4031)	144 (3657)	6 (160)	6 (160)	17,383 (7885)	17,436 (7909)
133 (3400)	96 (2438)	183 (4631)	168 (4257)	6 (160)	6 (160)	17,540 (7956)	17,593 (7980)
157 (4000)	108 (2738)	206 (5231)	192 (4857)	6 (160)	6 (160)	17,699 (8028)	17,751 (8052)
2-STAGE FULL FREE-LIFT (FFL) VISTA® MAST							
111 (2825)	85 (2138)	160 (4056)	147 (3731)	35 (907)	48 (1232)	17,485 (7931)	17,538 (7955)
134 (3425)	96 (2438)	184 (4656)	171 (4331)	47 (1207)	60 (1532)	17,648 (8005)	17,701 (8029)
3-STAGE FULL FREE-LIFT (FFL) VISTA® MAST							
163 (4147)	85 (2138)	212 (5378)	200 (5058)	35 (907)	48 (1227)	18,115 (8217)	18,168 (8241)
185 (4700)	92 (2338)	234 (5931)	221 (5611)	43 (1107)	56 (1427)	18,278 (8291)	18,331 (8315)
208 (5300)	100 (2538)	258 (6531)	245 (6211)	51 (1307)	64 (1627)	18,448 (8368)	18,501 (8392)

† Lift heights over 171.5" (4356 mm) maximum fork height are considered highlifts and require reduced capacity and restricted back tilt.
 Total approximate weights listed include mast, standard carriage, load backrest extension and 70 lbs. LP tank and tank bracket.
 RL = Rated Load NL = No Load

S120FT PRS MAST DIMENSIONS						
Maximum Fork Height (TOF) †	Overall Lowered Ht.	Overall Extended Height		Free-Lift (TOF)		Approximate Total Wt. of Standard Equipped Truck
		w/ Load Backrest	w/o Load Backrest	w/ Load Backrest	w/o Load Backrest	S120FT PRS with NL
in. (mm)	in. (mm)	in. (mm)	in. (mm)	in. (mm)	in. (mm)	lbs. (kg)
2-STAGE LIMITED FREE-LIFT (LFL) VISTA® MAST						
110 (2800)	85 (2138)	N/A	144 (3657)	N/A	6 (160)	18,686 (8476)
133 (3400)	96 (2438)	N/A	168 (4257)	N/A	6 (160)	18,843 (8547)
157 (4000)	108 (2738)	N/A	192 (4857)	N/A	6 (160)	19,001 (8619)
2-STAGE FULL FREE-LIFT (FFL) VISTA® MAST						
111 (2825)	85 (2138)	N/A	147 (3731)	N/A	48 (1232)	18,788 (8522)
134 (3425)	96 (2438)	N/A	171 (4331)	N/A	60 (1532)	18,951 (8596)
3-STAGE FULL FREE-LIFT (FFL) VISTA® MAST						
163 (4147)	85 (2138)	N/A	200 (5058)	N/A	48 (1227)	19,418 (8808)
185 (4700)	92 (2338)	N/A	221 (5611)	N/A	56 (1427)	19,581 (8882)
208 (5300)	100 (2538)	N/A	245 (6211)	N/A	64 (1627)	19,751 (8959)

† Lift heights over 171.5" (4356 mm) maximum fork height are considered highlifts and require reduced capacity and restricted back tilt.
 Total approximate weights listed include mast, standard carriage, load backrest extension and 70 lbs. LP tank and tank bracket.
 RL = Rated Load NL = No Load

STANDARD EQUIPMENT

Fortis®

Complete truck equipped with:

- GM 4.3L, V-6 emissions compliant engine
- Electronic powershift transmission
 - Electronic inching
 - Electronic shift control
- MONOTROL® pedal
- 2-Stage limited free-lift (LFL) VISTA® mast with maximum fork height of 120" (3050 mm) (S80FT and S80FT BCS) or 110" (2800 mm) (S100-120FT and S120FTS)
- 42.0" (1067 mm) wide hook-type carriage with 48.0" (1219) tall load backrest extension
- 42.0" (1067 mm) long forks
- 5 degrees forward and 6 degrees backward mast tilt
- 3-function hydraulic control valve
- Integrated dashboard display includes:
 - LCD Display:
 - Hour meter
 - Coolant Temp
 - Clock
 - Messages
 - Service Indicator Lights:
 - Alternator
 - Transmission oil temperature
 - Engine oil pressure
 - Brake fluid level
 - Fasten seatbelt
 - Engine malfunction
 - System malfunction
 - Park brake
 - Coolant temp
 - Forward, reverse and neutral direction indicators
- Hydrostatic power steering
- Non-suspension vinyl seat
- Electronic horn
- Adjustable steer column
- Rubber floor mat
- High air intake
- Integral tie downs
- Operator restraint system
- Heavy duty anti-clog radiator
- Single pedal inch brake
- Hyster® Stability Mechanism (HSM)
- Cowl-mounted hydraulic control levers
- Swing out LPG tank bracket
- 86" (2175 mm) Standard overhead guard
- 83" (2108 mm) Optional overhead guard
- 12 months / 2,000 hours manufacturer's warranty
- 24 months / 4,000 hours manufacturer's powertrain warranty
- Operator's manual
- UL Classification LP

Fortis® Advance

Complete truck equipped with:

- GM 4.3L, V-6 emissions compliant engine
- DuraMatch™ transmission
 - Electronic inching
 - Electronic shift control
 - Auto deceleration system
 - Controlled power reversal
 - Controlled roll back on ramps
- MONOTROL® pedal
- 2-Stage limited free-lift (LFL) VISTA® mast with maximum fork height of 120" (3050 mm) (S80FT and S80FT BCS) or 110" (2800 mm) (S100-120FT and S120FTS)
- 42.0" (1067 mm) wide hook-type carriage with 48" (1219) tall load backrest extension
- 42.0" (1067 mm) long forks
- 5 degrees forward and 6 degrees backward mast tilt
- 3-function hydraulic control valve
- Integrated dashboard display includes:
 - LCD Display:
 - Hour meter
 - Coolant Temp
 - Clock
 - Messages
 - Service Indicator Lights:
 - Alternator
 - Transmission oil temperature
 - Engine oil pressure
 - Brake fluid level
 - Fasten seatbelt
 - Engine malfunction
 - System malfunction
 - Park brake
 - Coolant temp
 - Forward, reverse and neutral direction indicators
- Hydrostatic power steering
- Non-suspension vinyl seat
- Electronic horn
- Adjustable steer column
- Rubber floor mat
- High air intake
- Integral tie downs
- Operator restraint system
- Heavy duty anti clog radiator
- Combi-cooler radiator
- Single pedal inch brake
- Hyster® Stability Mechanism (HSM)
- Cowl-mounted hydraulic control levers
- Swing out LPG tank bracket
- 86" (2175 mm) Standard overhead guard
- 83" (2108 mm) Optional overhead guard
- 12 months/2000 hours manufacturer's warranty
- 24 months/4000 hours manufacturer's powertrain warranty
- Operator's manual
- UL Classification LP

Fortis® Advance+

Complete truck equipped with:

- GM 4.3L, V-6 emissions compliant engine
- DuraMatch™ Plus2 transmission
 - Electronic inching
 - Electronic shift control
 - Auto deceleration system
 - Controlled power reversal
 - Controlled roll back on ramps
 - Auto-speed hydraulics
 - Throttle response management
 - Extended drawbar pull capability
- TouchPoint™ or TouchControl™ e-hydraulics
- MONOTROL® pedal
- 2-Stage limited free-lift (LFL) VISTA® mast with maximum fork height of 120" (3050 mm) (S80FT and S80FT BCS) or 110" (2800 mm) (S100-120FT and S120FTS)
- 42.0" (1067 mm) wide hook-type carriage with 48.0" (1219) tall load backrest extension
- 42.0" (1067 mm) long forks
- 5 degrees forward and 6 degrees backward mast tilt
- 3-function hydraulic control valve
- Integrated dashboard display includes:
 - LCD Display:
 - Hour meter
 - Coolant Temp
 - Clock
 - Messages
 - Service Indicator Lights:
 - Alternator
 - Transmission oil temperature
 - Engine oil pressure
 - Brake fluid level
 - Fasten seatbelt
 - Engine malfunction
 - System malfunction
 - Park brake
 - Coolant temp
 - 1st Gear lock-in
 - Forward, reverse and neutral direction indicators
- Hydrostatic power steering
- Full-suspension vinyl or cloth seat
- Electronic horn
- Adjustable steer column
- Rubber floor mat
- High air intake
- Integral tie downs
- Operator restraint system
- Combi-cooler radiator
- Single pedal inch brake
- Hyster® Stability Mechanism (HSM)
- Swing out LPG tank bracket
- 86" (2175 mm) Standard overhead guard
- 83" (2108 mm) Optional overhead guard
- 12 months / 2,000 hours manufacturer's warranty
- 24 months / 4,000 hours manufacturer's powertrain warranty
- Operator's manual
- UL Classification LP

OPTIONAL EQUIPMENT

- High intensity LED lights (brake/tail/back-up)
- Powertrain protection system
- Premium electronic monitoring
- High air intake with precleaner
- Accumulator
- Keyless start (with auxiliary key switch)
- Auto deceleration system (N/A with Fortis Package)
- Controlled power reversal feature (N/A with Fortis Package)
- Controlled roll back on ramps (N/A with Fortis Package)
- Oil-cooled wet disc brakes
- Traction speed limiter (included w/ Fortis® Advance+)
- Auto-speed hydraulics with throttle response management (DuraMatch Plus2)
- Powertrain protection system
- Paper Applications kit
- Vented hood
- Swing-out, drop-down EZXchange™ LPG tank bracket
- TouchPoint™ hydraulics with fully adjustable armrest (standard with Fortis® Advance+)
- TouchControl™ hydraulic control handle
- Return to set tilt
- Rear drive handle with horn button
- Semi-suspension seat - vinyl or cloth
- Full suspension seat - vinyl or cloth
- Swivel full-suspension seat - vinyl or cloth
- Impact monitor
- Load weight display
- Operator pre-shift checklist
- Dual inch brake pedals
- Password protection
- Audible Reverse activated 82-102 dB(A) self-adjusting alarm
- Visible amber strobe light - continuous activated, overhead guard mounted
- Various light packages
 - Two brake/back-up lights
 - Two front and one rear work lights
 - Two front, one rear work light and two brake/tail/back-up lights
- Parts publications - printed or CD, serial number specific
- UL Classification LPS



CAPACITY:

- Model S80FT:** 8,000 lbs. at 24.0" (3636 kg at 610 mm) load center.
Model S100FT: 10,000 lbs. at 24.0" (4545 kg at 610 mm) load center.
Model S120FT: 12,000 lbs. at 24.0" (5454 kg at 610 mm) load center.

RATED CAPACITIES ARE FOR TRUCKS EQUIPPED WITH:

- 3-Stage full free-lift (FFL) VISTA® mast to 171.5" (4,356 mm) maximum fork height
- 42.0" (1,067 mm) Hook-type carriage with 42.0" (1,067 mm) long forks
- 48.0" Tall load backrest extension (LBE)
- Standard tread

MASTS

Masts are available in 2-stage limited free (LFL) lift and 2- or 3-stage full free-lift (FFL) VISTA® masts.

Masts feature flush-faced, nested-channel design and full-radius, angled load rollers provide increased capacity at height while affording shorter overall length.

CARRIAGE

Carriages are hook-type, ITA Class III mounting (S80FT, S80FT BCS), ITA Class IV (S100-120FT, S100FT BCS, S120FT PRS). Overall width without load backrest extension (LBE) is 42.0" (1067 mm); with LBE is 43.27" (1099 mm). Minimum inside-to-inside fork spacing, center to center is 5.1" (130 mm). Maximum outside-to-outside fork spacing, center to center is 33.5" (845 mm) for S80FT and 32.0" (810 mm) for S100FT and S120FT.

FORKS

S80FT lift trucks feature: 2.0" x 5.0" x 36.0" to 60.0" (50 x 125 x 915 to 1 525 mm) long pallet forks.

S100FT lift trucks feature: 2.0" x 6.0" x 36.0" to 72.0" (50 x 150 x 915 to 1 830 mm) long pallet forks.

S120FT lift trucks feature: 2.5" x 6.0" x 36.0" to 72.0" (60 x 150 x 915 to 1 830 mm) long pallet forks.

Polished and full bottom tapered forks are also available.

ENGINE

GM 4.3L emissions compliant engine features:

- Cast iron block cylinder heads with hardened intake valve and exhaust valve seats, and hydraulic lifters
- Electronically controlled LPG fuel system
- Spin-on full flow oil filter
- Direct port injection
- Drive-by-wire throttle control
- Electronic governor
- Heavy-duty air cleaner with pre-cleaner
- Engine Control Unit (ECU)
- Three-way catalytic converter exhaust system
- 4.3L engine produces 98 horsepower

TRANSMISSION

- Standard Electronic Powershift: Single range powershift, electronic inching (requires no adjustment), electric shift control, neutral start switch, and anti-restart protection
- DuraMatch™: All of the features of the standard electronic transmission plus Auto Deceleration System, controlled power reversal, controlled roll back on ramps

- DuraMatch™ 2: All of the features of the DuraMatch with 2 speeds for low end power and improved top speed. Includes traction speed limiter option
- DuraMatch™ Plus2: All of the features of the DuraMatch™ plus auto-speed hydraulics and throttle response management

COOLING SYSTEM

- Two cooling system designs, depending on transmission configuration:
 - Heavy duty square-wave anti-clog
 - Square-wave anti-clog Combi-cooler
- All radiators utilize cross-flow aluminum cores, pusher type fans and permanently lubricated water pump
- "Knife-edge" type fan shrouds that direct air flow through the counterweight air passages
- 15 psi operating system pressure
- Combi-cooler contains an externally mounted transmission oil cooler to aid in heat dissipation

ELECTRICAL SYSTEM

- CANbus electrical system simplifies truck wiring and enhances truck dependability
- IPP 66 sealed automotive style electrical connectors
- Standardized wire routing, all wires are color coded, and marked with numbers for easy identification
- Vehicle System Manager (VSM) directly or indirectly controls all electrical functions except those controlled by the Engine Control Unit (ECU)
- 12-volt maintenance free battery provides 475 cold cranking amps (cca) for easy starts
- Onboard diagnostics monitoring and feedback

HYDRAULIC SYSTEM

Manual Hydraulic Control Valve & Electro-Hydraulic Control Valve

- Hydraulic lift system operates at 3200 psi (221 bar)
- Tilt and auxiliary systems have 2,250 psi (15.5 Mpa) relief pressure in all valve variations
- Hydraulic system is protected by a replaceable 10-micron element in-tank filter assembly
- Hydraulic breather filter includes an anti-splash baffle and is rated at three micron.
- O-Ring face seal fittings with captive O-Ring grooves are used on all high pressure connections
- Electro-hydraulic controls feature an emergency lowering valve allowing load to be lowered in the event of battery power loss.
- 100 Mesh suction line strainer

STEER AXLE / STEER SYSTEM

- Equal-area, double-ended, hydrostatic steering cylinder is mounted in cast ductile iron axle frame
- Elastomeric axle mounts absorb shock and allow lubrication free articulation
- Axle assembly utilizes synthetic boots and seals to retain lubricants and shield components against destructive grit and reduce lube points
- Wheel hubs rotate on large, tapered roller bearings.
- Top spindle bearings lubricated through easy access lube fittings
- Hydrostatic steer system provides smooth, precise steering with only 4 turns lock-to-lock
- Hyster® Stability Mechanism enhances lateral stability by limiting steer axle articulation without a compromise in uneven surface travel

BRAKES

- Asbestos free, self-energizing, automatically adjusting drum brake assemblies
- Single circuit master cylinder with sealed fluid reservoir and magnetic fluid level sensor
- Ratchet-type, hand-activated parking brake lever allows controlled application
- Oil-cooled wet disc brakes provide extremely long service life and are protected from dirt and moisture (Fortis® Advance and Fortis® Advance+)

OPERATOR COMPARTMENT

- Cowl-mounted hydraulic control levers (Standard on Fortis® and Fortis® Advance).
- TouchPoint™ electro-hydraulic seat side mini-levers (Standard on Fortis® Advance+).
- TouchControl™ hydraulic seat side joystick (optional).
- 12-Inch textured steering wheel with spinner knob.
- Automotive style foot controls with single braking/inching pedal (dual pedals are optional)
- Integrated dashboard display is backlit, allowing easy visibility under all lighting conditions
- Grid-style overhead guard offers superb visibility at extended heights
- Infinitely adjustable tilt steer column
- Optimal 15.6" entry step height on both sides of the truck
- MONOTROL® pedal controls engine speed and truck direction, freeing operator's hands to operate steering and hydraulic levers.

Special attachments, equipment or accessories not listed above may be available through Applications Engineering for specific application requirements.



FLEET SERVICES



HYSTER CAPITAL

A Division of NMHG Financial Services, Inc.

It's not just about the lift trucks.

Any company worth its weight knows success has just as much to do with the support before and after the sale as the sale itself. We pride ourselves on being more than just a lift truck manufacturer. Through our Dealer Network, we're also fleet managers, parts suppliers, capital procurement specialists and trainers. You'll find that when it comes to service, we do it all.

Hyster Fleet Services

As much as we'd like for your entire fleet to be Hyster, we know that's not always the case. But just because you also operate other brands doesn't mean we can't manage your lift truck maintenance and replacement plan. We can analyze your current fleet or provide summary of your fleet history and a cost-effective proposal for replacement and scheduled maintenance of all your vehicles. Once this initial review is complete, we'll continue to monitor your fleet to ensure it's performing optimally.

UNISOURCE™ Parts Program

In addition to providing fleet management for a variety of brands, we can also serve as your source of parts for all your lift trucks. With the Hyster UNISOURCE parts and service program, we offer approximately 2 million part number crosses for most brands of materials handling and other in-plant mobile equipment. UNISOURCE also has remanufactured parts that provide the same quality and guarantee but at a lower price. And we can deliver parts to you in less than 24 hours, any day of the week. How's that for convenience?

Rental Products

At Hyster Company, we're always looking for ways to help you keep your productivity up. Through the Hyster Dealer Network, you can access rental equipment for the times when leasing or buying isn't a practical option. Your local Hyster Dealer has access to over 14,000 units that are available for short- or long-term rental. Whether you need one truck to substitute for a vehicle that's being serviced or several lift trucks to accommodate seasonal changes in your business, we'll help you maintain output in a cost-effective manner.

Hyster Capital

We know that financing new additions to your fleet can sometimes be challenging. That's why your Hyster Dealer has a long list of ways for you to fund your purchase. We are skilled in arranging solutions for special financing requirements, taking the difficulties out of buying the equipment you need. Whether you purchase or lease a new or used lift truck, Hyster Capital offers better service and competitive rates, ensuring you receive the value you deserve.

Special Products

Engineering Department (SPED)

In a perfect world, every application could be handled with a standard lift truck. However, in the real world, different materials require different handling. That's why Hyster Company's Special Products Engineering Department works with you to customize* your lift trucks. From strobe lights to specially made forks, SPED can provide you with the tools you require to get the job done right.

** May be subject to an additional charge. Contact your local authorized Hyster Dealer for more information.*

Automated Warehouse Solutions

As society's technological capabilities advance, we strive to find practical applications. One of our most recent innovations in that pursuit is our development of automated warehouse solutions. We can help you determine if your operation would benefit from this type of system, which improves inventory accuracy, warehouse productivity and safety records, as it reduces maintenance and overtime.

Operator and Service Training

Hyster Company recognizes that proper training is a key element of a profitable company. That's why your local authorized Hyster Dealer offers a training program for your lift truck operators as well as those who maintain your vehicles. Proper education in running and servicing lift trucks cuts down on the number of repairs and risk of injuries due to accidents while increasing productivity. All of our trainers are professionals with experience in materials handling.





Hyster Company
P.O. Box 7006
Greenville, North Carolina
27835-7006
Part No. S80-120FT/BTG
1/2007 Litho in U.S.A.

**Visit us online at www.hysteramericas.com
or call us at 1-800-HYSTER-1.**

Hyster, , Fortis, and MONOTROL are registered trademarks of Hyster Company. Hyster products are subject to change without notice.

The Hyster Company products included in this document may be covered by U.S. Patent 6,684,148 and other patents pending.
Truck on cover shown with optional equipment. ©2006 Hyster Company. All rights reserved.

