



STRONG PARTNERS. TOUGH TRUCKS.™

W40Z SERIES

Walkie Motorized, Hand, Low Lift Pallet Truck





THE HYSTER® ADVANTAGE

MANEUVERABILITY:

The Hyster® W40Z is redefining navigation in small spaces. The attributes of this general-purpose Walkie greatly enhance maneuverability on crowded loading docks and inside narrow trailers.

- Standard W40Z creep speed function allows truck to run with the control handle in the full “up” position, giving operators better visibility by placing them closer to loads.
- Fingertip control of all truck functions with either hand aids steering and pallet positioning in tight spots.
- Freighter’s Special option offers shorter fork tips and a unique bumper profile, making loads easier to pin-wheel inside trailers.

PRODUCTIVITY:

It’s a simple fact of your business that you need to move your product quickly and efficiently with minimum downtime. The W40Z helps you do just that with several productivity-enhancing features.

- The Auto Deceleration System extends traction motor brush and brake life by automatically slowing the truck when the accelerator is released, translating to a longer life – and more time spent working.
- The solid state transistor controls significantly reduce the number of parts, maximizing uptime.
- Regular maintenance is simplified by a 40 percent reduction in electrical connections and easily identifiable wiring.
- The optional 48- or 60-inch load backrest extension maximizes load capabilities to increase efficiency.

EASE OF USE:

The superior ergonomic design of the W40Z makes operators noticeably more efficient.

- The control handle design allows the operator to command all truck functions at their fingertips, no matter which hand they use.
- Ergonomically angled handgrips and a contoured handle design provide comfortable operator positioning and protection for fingers and knuckles during operation.
- The handle features a direction throttle control actuator that provides 30° rotation in either direction, making it easy to actuate through the full range of motion.
- Wrap around traction reversing button provides a large area of contact.



◀ The standard creep speed feature greatly increases maneuverability by allowing the W40Z to operate with the handle in the full upright position. With the Freighter’s Special option, the steer handle is kept away from the side of the trailer during pin-wheeling.

W40Z

Volume is key in any warehousing or retailing application. Hyster Company helps you boost yours with the W40Z Walkie pallet truck. Its exceptional maneuverability stems from legendary Hyster ergonomics and performance innovations. Features such as creep speed and fingertip control put the power to be productive in your operators’ hands. The Cooler / Freezer Package makes the W40Z an excellent tool in environments with operating temperatures ranging from 0° to 120° F. And the greater maneuverability of the Freighter’s Special makes it possible to place two additional pallets in a trailer – quickly and efficiently. So, when it comes to raising your throughput, the Hyster W40Z is the clear choice.



Great Things Come in Small Packages.

Hyster engineers are always looking for ways to make your job easier. That's why they've designed the Freighter's Special, an option exclusive to the Hyster W40Z. The Freighter's Special shares the same superior ergonomic and enhanced serviceability features as the standard W40Z, but it also has a few perks all its own.

Hyster Company has shortened the fork tip length of the W40Z by two inches and redesigned the bumper to provide a tighter right angle turn for easier right angle stacking and equal aisle placement. The fully boxed fork tips improve angled pallet entry, allowing the forks to straddle the centerboard when

pin-wheeling and entering the pallet at a right angle.

Operators will appreciate the creep/turtle speed feature that allows the W40Z to be operated with the handle in the "up" position. Offering better visibility, operators are able to get closer to their loads. Placing pallets becomes more precise, minimizing the likelihood of product damage.

The combination of shorter fork tips and unique bumper profile allows operators to load two additional pallets per trailer, boosting their productivity and your throughput.

All this means that when space is at a premium, the W40Z Freighter's Special is a perfect fit.

Leave it to Hyster Company to find a solution to meet your materials handling needs.

REAR BUMPER



BOLT-ON STABILITY TABS



SHORT FORK TIPS



FEATURES

STANDARD

24 Volt

SEM Transistor Control with Integrated Hoist Control

48" Long Forks

27" Fork Spread

Low Battery Lift Interrupt

Lift Motor Time-out at Full Height

Standard Construction

Operating Temperatures:
+32° to +120° F

Flush Pallet Stop

Electromagnetic Park Brake with Service Override

Regenerative Braking

Press-on Rubber Drive Tire (9" x 5")

Impact-Resistant, Ergonomically Designed, Bottom Mount Control Handle with Gas Spring Return

Direction Reversing Switch

Creep Speed "Turtle" Button

Three User Selectable Performance Modes

OPTIONAL

Fork Lengths

36" Long Forks

42" Long Forks

Fork Spread

18" Fork Spread

22" Fork Spread

Note: Fork dimensions listed (length, spread, width) are nominal. See specifications page for actual dimensions.

Optional Construction

Cooler / Freezer Package:
0° to +120° F

Load Backrest

48" High (Bolt-on)*

60" High (Bolt-on)*

**Cowl Mount 8.1" Battery Compartment Mount 9.1", increases truck length by 2"*

Freighter's Special

45.2" "Freighter's Special" Fork Configuration

Redesigned Bumper Profile

Battery

12-85-7 Industrial Battery with 28.0" x 9.1" Battery Compartment, increases truck length by 1"



Trucks shown with optional equipment.

DIMENSIONS

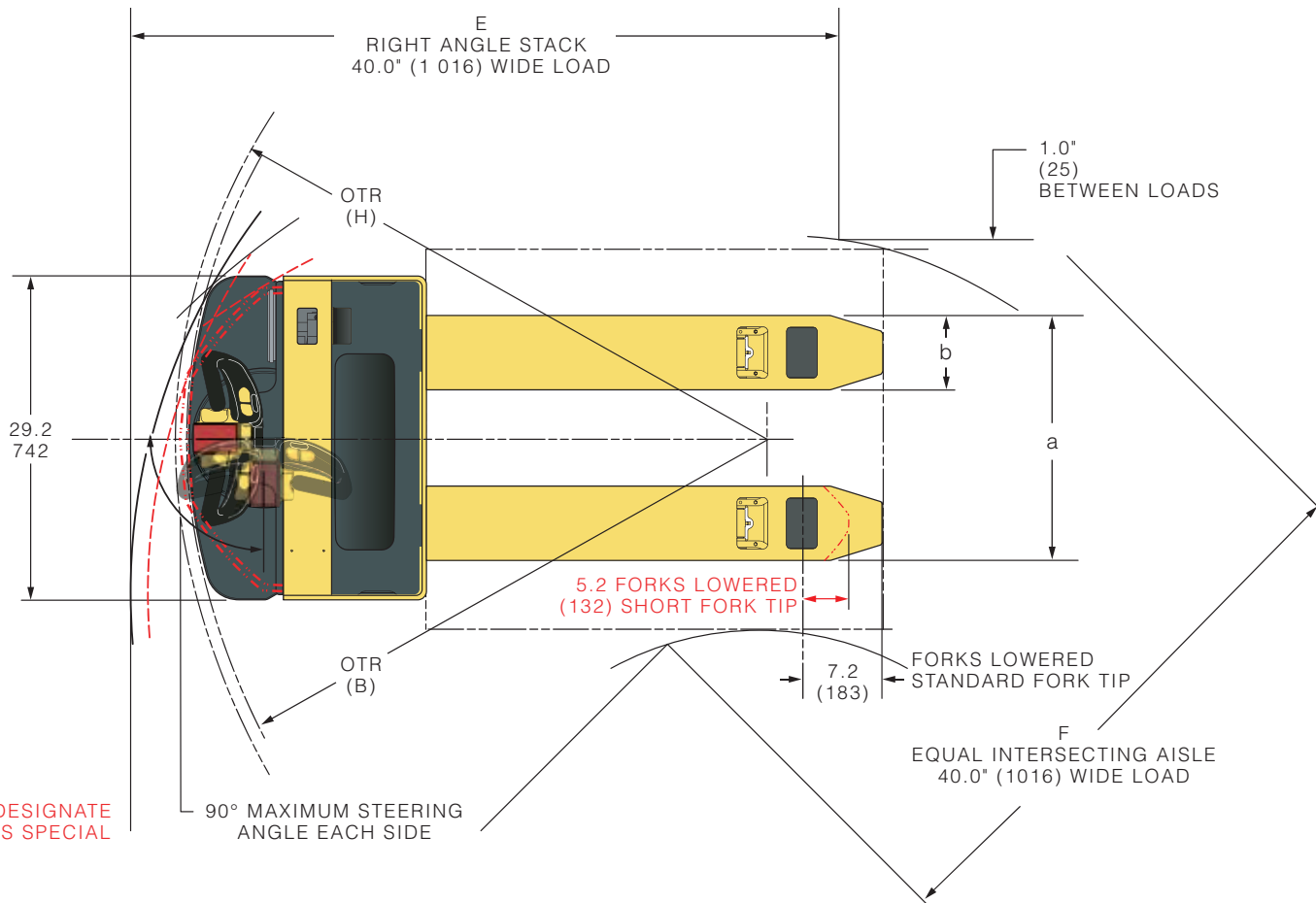
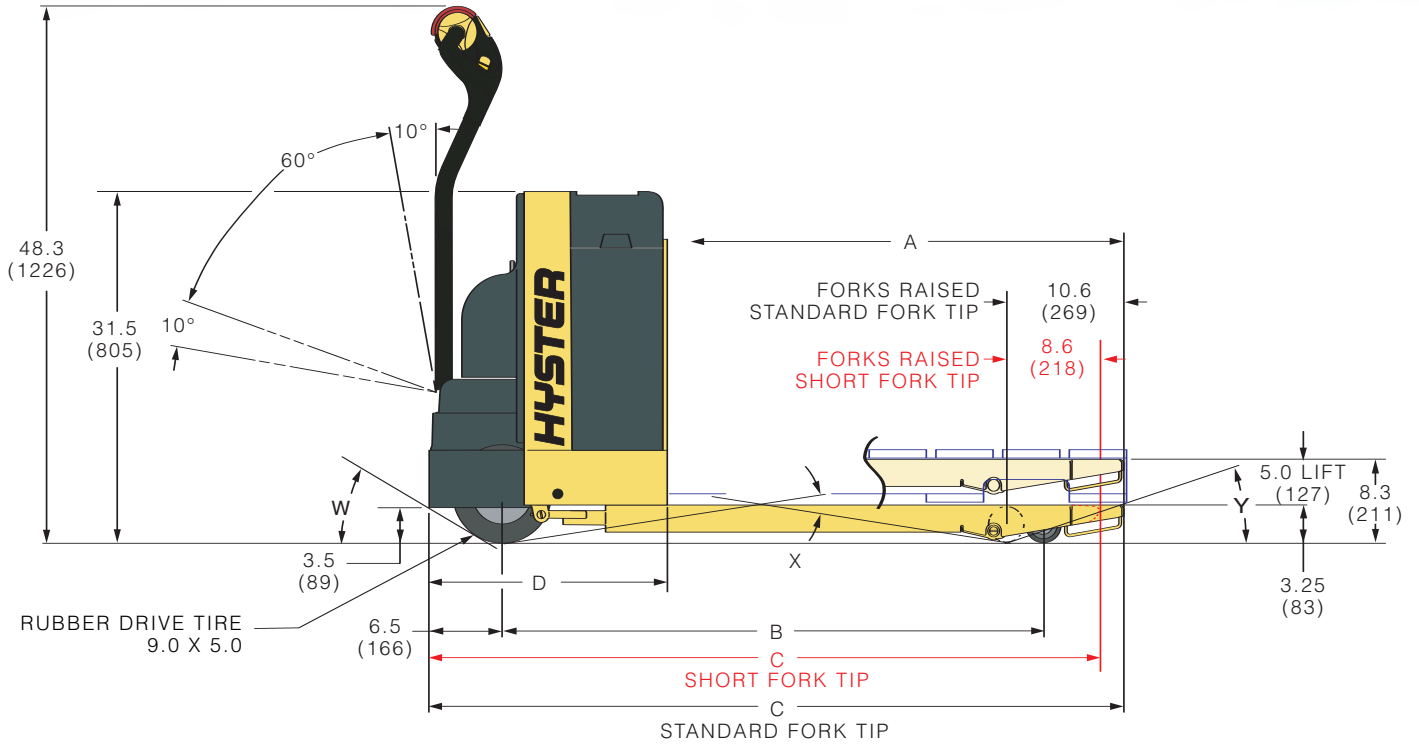

RED LINES DESIGNATE FREIGHTER'S SPECIAL

SPECIFICATIONS



TRUCK DIMENSIONS: SINGLE LOAD WHEELS, 24 VOLT, 28.5" x 8.1" BATTERY COMPARTMENT

DIMENSION	DESCRIPTION		FORK POSITION	DIMENSIONS IN INCHES (MILLIMETERS)			
				W40Z Standard Fork Tip			W40Z Freighter's Special
	Fork Type			W40Z Standard Fork Tip			W40Z Freighter's Special
A	Fork Length	Nominal	–	36 (900)	42 (1050)	48 (1200)	48 (1200)
		Actual	–	35.4 (899)	41.3 (1049)	47.2 (1199)	45.2 (1148)
B	Wheel Base		Raised	39.7 (1008)	45.6 (1158)	51.5 (1308)	51.5 (1308)
			Lowered	43.1 (1095)	49.0 (1245)	54.9 (1395)	54.9 (1395)
C	Overall Length		–	56.8 (1442)	62.7 (1592)	68.6 (1742)	66.6 (1691)
D	Chassis Length		–	21.4 (544)	21.4 (544)	21.4 (544)	21.4 (544)
OTR (b)	Outside Turning Radius (bumper)		Raised	46.2 (1174)	52.1 (1324)	58.0 (1474)	58.0 (1474)
			Lowered	49.6 (1261)	55.6 (1411)	61.5 (1561)	61.5 (1561)
OTR (h)	Outside Turning Radius (handle)		Raised	47.5 (1206)	53.4 (1356)	59.3 (1506)	59.3 (1506)
			Lowered	50.9 (1293)	56.8 (1443)	62.7 (1593)	62.7 (1593)
E	Right Angle Stack (aisle)		Raised	61.5 (1562)	66.5 (1689)	71.3 (1810)	69.0 (1753)
F	Equal Intersecting Aisle		–	52.5 (1334)	54.9 (1394)	57.5 (1460)	56.0 (1422)
W	% Grade Clearance ¹		Raised	67%	67%	67%	67%
X	% Grade Clearance ¹		Raised	40%	34%	30%	30%
Y	% Grade Clearance ¹		Raised	33%	33%	33%	33%
	Right Angle Stack* (truck)		Raised	–	–	100.4 (2550)	95.0 (2413)

¹ Measured to the bottom of a GMA approved pallet on the forks while they are in the raised position.

* Length is measured side to side of truck. Width is measured front to back on the truck.

FORK DIMENSIONS

DIMENSION	DESCRIPTION		DIMENSIONS IN INCHES (MILLIMETERS)		
a	Fork OAW (Over All Width)	Nominal	18 (460)	22 (560)	27 (670)
		Actual	18.1 (460)	22.0 (560)	26.4 (670)
b	Fork Width	Nominal	7.0 (170)	7.0 (170)	7.0 (170)
		Actual	6.9 (170)	6.9 (170)	6.9 (170)

PERFORMANCE



BATTERY SPECIFICATIONS AND WEIGHTS

BATTERY	CAPACITY AMP-HOURS	(6 HR RATE) KWH	BATTERY CONNECTOR	LENGTH	WIDTH	HEIGHT	NOMINAL WEIGHT
Standard Battery Pack with 12A Charger	158	4.0	X type-175 Amp Red	28.4" (721 mm)	7.9" (201 mm)	23.9" (607 mm)	310 lbs. (141 kg)
GNB PalletPro® Battery Pack with 25A Charger ^s	195	4.4	175 Amp Red	27.3" (693 mm)	7.5" (191 mm)	26.4" (671 mm)	375 lbs. (170 kg)
12-85-7 Industrial Battery	255	6.0	175 Amp Red	25.7" (653 mm)	8.8" (224 mm)	23.3" (592 mm)	570 lbs. (259 kg)

Battery cable length 20.0 inch (508 mm), 1/0 gauge leads, B position. Truck weight, total approx. with battery power pack - 850 lbs. (386 kg) ^s GNB PalletPro® battery pack requires a .5 in. (12 mm) thick backplate spacer for proper positioning. Standard battery well 28.5" (724 mm) x 8.1" (206 mm) x open. Optional battery well 28.0" (712 mm) x 9.1" (231 mm) x open. Please note battery size is limited by the rounded corners of battery compartment. Maximum battery width and length dimensions cannot be used in conjunction with each other. Please contact your local Hyster Dealer for more information and details.

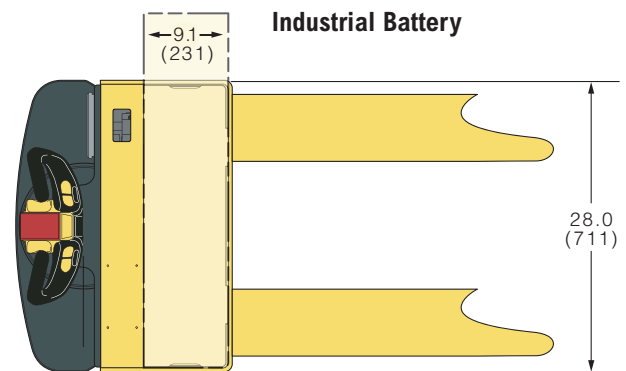
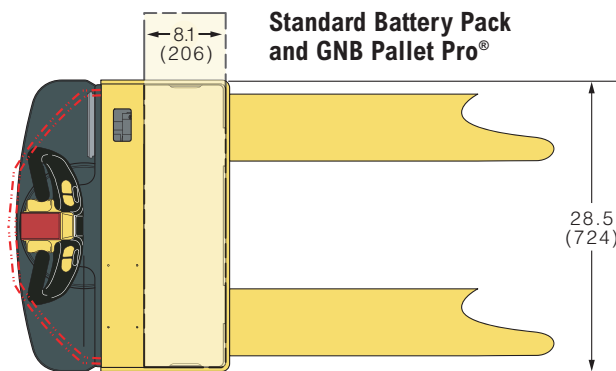

TRAVEL SPEEDS (USER SELECTABLE PERFORMANCE MODES)

MODE 1			
	No Load	4000 lbs. (1818 kg)	
	Speed	Speed	
mph	3.4	2.7	
kph	5.5	4.3	

MODE 2			
	No Load	4000 lbs. (1818 kg)	
	Speed	Speed	
mph	3.6	3.2	
kph	5.8	5.1	

MODE 3			
	No Load	4000 lbs. (1818 kg)	
	Speed	Speed	
mph	3.8	3.4	
kph	6.1	5.5	

24 Volt SEM Traction Control: 9" x 5" Rubber Drive Tire, Single Poly Load Wheels **Industrial Battery:** 600 lbs. (273 kg); 300 amp-hours

LIFT / LOWER INFORMATION

24 VOLT			
Lift Time	Sec	No Load	3.0
	Sec	4000 lbs.	4.0
Lowering Time	Sec	No Load	2.0
	Sec	4000 lbs.	1.0

GMA PALLET – STANDARD DIMENSIONS

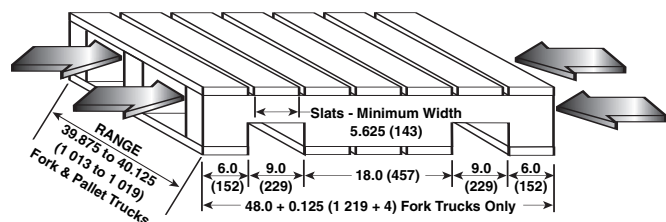



FLEET SERVICES

It's not just about the lift trucks.

Any company worth its weight knows success has just as much to do with the support before and after the sale as the sale itself. We pride ourselves on being more than just a lift truck manufacturer. Through our Dealer Network, we're also fleet managers, parts suppliers, capital procurement specialists and trainers. You'll find that when it comes to service, there's not much we don't do.

Hyster® Fleet Services

As much as we'd like for your entire fleet to be Hyster, we know that's not always the case. But just because you also operate other brands doesn't mean we can't manage your lift truck maintenance and replacement plan. We can analyze your current fleet or provide a summary of your fleet history and a cost-effective proposal for replacement and scheduled maintenance of all your vehicles. Once this initial review is complete, we'll continue to monitor your fleet to ensure it's performing optimally.

UNISOURCE™ Parts Program

In addition to providing fleet management for a variety of brands, we can also serve as your source of parts for all your lift trucks. With the Hyster UNISOURCE parts and service program, we offer approximately 2 million part number crosses for most brands of materials handling and other in-plant mobile equipment. UNISOURCE also has remanufactured parts that provide the same quality and guarantee but at a lower price. And we can deliver parts to you in less than 24 hours, any day of the week. How's that for convenience?



Rental Products

At Hyster Company, we're always looking for ways to help you keep your productivity up. Through the Hyster Dealer Network, you can access rental equipment for the times when leasing or buying isn't a practical option. Your local Hyster Dealer has access to over 14,000 units that are available for short- or long-term rental. Whether you need one truck to substitute for a vehicle that's being serviced or several lift trucks to accommodate seasonal changes in your business, we'll help you maintain output in a cost-effective manner.

Hyster® Capital

We know that financing new additions to your fleet can sometimes be challenging. That's why your Hyster Dealer has a long list of ways for you to fund your purchase. We are skilled in arranging solutions for special financing requirements, taking the difficulties out of buying the equipment you need. Whether you purchase or lease a new or used lift truck, Hyster Capital offers flexible service and competitive rates, ensuring you receive the value you deserve.

Special Products Engineering Department (SPED)

In a perfect world, every application could be handled with a standard lift truck. However, in the real world, different materials require different handling. That's why Hyster Company's Special Products Engineering Department works with you to customize* your lift trucks. From strobe lights to specially made forks, SPED can provide you with the tools you require to get the job done right.

* May be subject to an additional charge. Contact your local Authorized Hyster Dealer for more information.



HYSTER CAPITAL

A Division of NMHG Financial Services, Inc.

Automated Warehouse Solutions

As society's technological capabilities advance, we strive to find practical applications. One of our most recent innovations in that pursuit is our development of automated warehouse solutions. We can help you determine if your operation would benefit from this type of system, which improves inventory accuracy, warehouse productivity and safety records, as it reduces maintenance and overtime.

Operator and Service Training

Hyster Company recognizes that proper training is a key element of a profitable company. That's why your local Authorized Hyster Dealer offers a training program for your lift truck operators as well as those who maintain your vehicles. Proper education in running and servicing lift trucks cuts down on the number of repairs and risk of injuries due to accidents while increasing productivity. All of our trainers are professionals with experience in materials handling.



Hyster Company
P.O. Box 7006
Greenville, North Carolina
27835-7006
Part No. W40Z/BTG
1/2006 Litho in U.S.A.

Visit us online at www.hysterusa.com or call us at 1-800-HYSTER-1.

Hyster and  are registered trademarks of Hyster Company.  is a trademark of Hyster Company. Hyster products are subject to change without notice.
GNB PalletPro is a registered trademark of its respective company.
©2006 Hyster Company. All rights reserved.





STRONG PARTNERS. TOUGH TRUCKS.™

W50Z SERIES

Walkie Motorized, Hand, Low Lift Pallet Truck



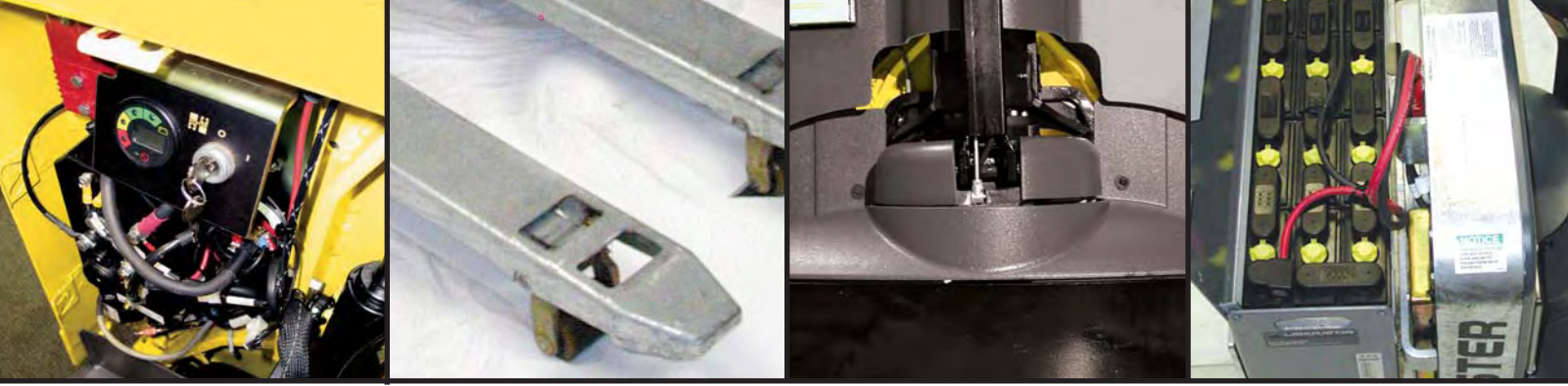

THE HYSTER® ADVANTAGE

DURABILITY:

When you've got a job to do, you need to know your equipment is tough enough to make it through. That's why Hyster Company developed the exceptionally rugged W50Z Series low lift pallet truck.

- Reduced wiring complexity and fewer service parts contribute to less required maintenance and longer truck life.
- Four application / environmental construction options allow additional component protection for your specific usage and temperature range:
 - Standard Construction: +32° to +120° F
 - Cooler/Freezer Package: 0° to +120° F
 - **SUBZERO** Freezer Package: -40° to +120°F (increases truck length by 2")
 - Extreme Corrosion/Wash Down Package: 0° to +120° F (increases truck length by 2")
 - This Hyster® exclusive package features a rust-resistant, unpainted galvanized frame designed to reduce overall surface corrosion and rust.
 - No downtime/labor costs associated with periodic repainting.
 - Ideal for applications where the truck is exposed to corrosive agents or is required to be washed down.

MANEUVERABILITY:

When designing the Hyster W50Z, our engineers kept in mind the small spaces it would be used in. They made it supremely easy to maneuver around crowded loading docks.

- Standard W50Z creep speed function allows the truck to be run with the control handle in the full "up" position, placing operators closer to loads for better visibility.
- Fingertip control of all truck functions with either hand aids steering and pallet positioning in tight spots.
- Ergonomically angled handgrips and a contoured body provide comfortable operator positioning and protection for fingers and knuckles during operation.
- Wrap around traction reversing button provides a large area of contact.
- The handle features a direction throttle control actuator that provides 30° rotation in either direction, making it easy to actuate through the full range of motion.



PRODUCTIVITY:

The Hyster W50Z is designed to boost operator productivity through ease of use and less need for maintenance. Several features contribute to the unit's ease of use and reduced service requirements.

- The Auto Deceleration System extends traction motor brush and brake life by automatically slowing the truck when the accelerator is released, translating to a longer life – and more time spent working.
- Regular maintenance is simplified by a 40 percent reduction in electrical connections and easily identifiable wiring.
- The optional 48- and 60-inch load backrest extension maximizes load capabilities to increase efficiency.
- Four application / environmental construction option packages tailor the W50Z to your specific usage needs to reduce downtime related to temperature intolerance.

◀ The standard creep speed feature greatly increases maneuverability by allowing the W50Z to operate with the handle in the full upright position.

W50Z If a pallet truck's true value is its capacity for productivity, the Hyster W50Z is worth its weight in gold. Exceptional maneuverability and industry-exclusive options give your operators the power to get more done. Four different application / environmental construction packages ensure the W50Z can stand up to even your most demanding tasks without breaking a sweat. So, when you have a job to do, rely on the Hyster® W50Z.



GALVANIZED FRAME

Hyster® Trucks Withstand Even Your Tough Jobs

The environmental standards required in applications where a unit is exposed to corrosive agents or is required to be washed down call for extra diligence in protecting against contaminants when compared to trucks running in normal operating conditions. Units operating in high corrosive environments display accelerated surface rust and corrosion more quickly, which is why Hyster Company is proud to introduce a real, long-term solution: The Extreme Corrosion/Wash Down Package includes a completely galvanized frame, lift linkage, battery well and fork weldment.

This optional configuration is unpainted and rust-resistant, eliminating the risk of airborne contaminants in the form of paint or rust flakes. This also does away with the need for periodic scraping and repainting, allowing your operators to be more productive. The W50Z galvanized frame pallet truck is the first 5,000-pound capacity truck designed for use in highly corrosive environments like the food processing, pickling, tannery, chemical, salt and brine industries.



GALVANIZED UNDERCARRIAGE



CONTROL COMPARTMENT



SPECIFICATIONS



TRUCK DIMENSIONS (SUBZERO FREEZER & EXTREME CORROSION/WASH DOWN CONSTRUCTION)

DIMENSION	DESCRIPTION	FORK POSITION	DIMENSIONS IN INCHES (MILLIMETERS)				
A	Fork Length	Nominal	–	36 (900)	42 (1050)	48 (1200)	60 (1500)
		Actual	–	35.4 (899)	41.3 (1049)	47.2 (1199)	59.0 (1499)
B	Wheel Base without Load Backrest	Raised		43.0 (1092)	48.9 (1242)	54.8 (1392)	66.6 (1692)
		Lowered		46.1 (1171)	52.0 (1321)	57.9 (1471)	69.7 (1770)
B	Wheel Base with Load Backrest	Raised		45.0 (1143)	50.9 (1293)	56.8 (1443)	68.6 (1742)
		Lowered		48.1 (1222)	54.0 (1372)	59.9 (1521)	71.7 (1821)
C	Overall Length without Load Backrest	–		59.8 (1519)	65.7 (1669)	71.6 (1819)	83.4 (2118)
C	Overall Length with Load Backrest	–		61.8 (1570)	67.7 (1720)	73.6 (1869)	85.4 (2169)
D	Chassis Length	–		24.4 (620)	24.4 (620)	24.4 (620)	24.4 (620)
OTR (b)	Outside Turning Radius (bumper) without Load Backrest	Raised		49.5 (1257)	55.4 (1407)	61.3 (1557)	73.2 (1859)
		Lowered		52.6 (1336)	58.5 (1486)	64.4 (1636)	76.2 (1935)
OTR (b)	Outside Turning Radius (bumper) with Load Backrest	Raised		51.5 (1308)	57.4 (1458)	63.3 (1608)	75.2 (1910)
		Lowered		54.6 (1387)	60.5 (1537)	66.4 (1687)	78.2 (1986)
OTR (h)	Outside Turning Radius (handle) without Load Backrest	Raised		50.9 (1293)	56.8 (1443)	62.7 (1593)	74.6 (1895)
		Lowered		54.1 (1374)	60.0 (1524)	65.9 (1674)	77.7 (1974)
OTR (h)	Outside Turning Radius (handle) with Load Backrest	Raised		52.9 (1344)	58.8 (1494)	64.7 (1643)	76.6 (1946)
		Lowered		56.1 (1425)	62.0 (1575)	67.9 (1725)	79.7 (2024)
E	Right Angle Stack (aisle) without Load Backrest	Raised		63.2 (1605)	68.0 (1727)	73.0 (1854)	83.5 (2121)
E	Right Angle Stack (aisle) with Load Backrest	Raised		64.9 (1648)	69.7 (1770)	74.6 (1895)	85.2 (2164)
F	Equal Intersecting Aisle without Load Backrest	Raised		53.2 (1351)	56.3 (1430)	59.4 (1509)	65.6 (1666)
F	Equal Intersecting Aisle with Load Backrest	Raised		54.2 (1377)	57.3 (1455)	60.4 (1534)	66.6 (1692)
W	% Grade Clearance ¹	Raised		67%	67%	67%	67%
X	% Grade Clearance ¹	Raised		35%	30%	26%	21%
Y	% Grade Clearance ¹	Raised		33%	33%	33%	33%

¹ Measured to the bottom of a GMA approved pallet on the forks while they are in the raised position.

TRAVEL SPEEDS (USER SELECTABLE PERFORMANCE MODES)

MODE 1			MODE 2			MODE 3		
	No Load	5000 lbs. (2268 kg)		No Load	5000 lbs. (2268 kg)		No Load	5000 lbs. (2268 kg)
	Speed	Speed		Speed	Speed		Speed	Speed
mph	2.6	2.4	mph	3.7	2.8	mph	4.2	2.9
kph	4.2	3.9	kph	6.0	4.5	kph	6.8	4.7

24 Volt SEM Traction Control: 9" x 5" Rubber Drive Tire, Single Poly Load Wheels **Industrial Battery:** 600 lbs. (273 kg); 300 amp-hours

FORK DIMENSIONS

DIMENSION	DESCRIPTION		DIMENSIONS IN INCHES (MILLIMETERS)		
a	Fork Spread	Nominal	18 (460)	22 (560)	27 (670)
		Actual	18.1 (460)	22.0 (560)	26.4 (670)
b	Fork Width	Nominal	7.0 (170)	7.0 (170)	7.0 (170)
		Actual	6.9 (170)	6.9 (170)	6.9 (170)

LIFT / LOWER INFORMATION

24 VOLT			
Lift Time	Sec	No Load	2.0
	Sec	5000 lbs.	3.2
Lowering Time	Sec	No Load	1.8
	Sec	5000 lbs.	1.0

SPECIFICATIONS



TRUCK DIMENSIONS (STANDARD & COOLER/FREEZER CONSTRUCTION)

DIMENSION	DESCRIPTION	FORK POSITION	DIMENSIONS IN INCHES (MILLIMETERS)				
A	Fork Length	Nominal	–	36 (900)	42 (1050)	48 (1200)	60 (1500)
		Actual	–	35.4 (899)	41.3 (1049)	47.2 (1199)	59.0 (1499)
B	Wheel Base without Load Backrest	Raised		41.0 (1040)	46.9 (1190)	52.8 (1340)	64.6 (1640)
		Lowered		44.1 (1120)	50.0 (1270)	55.9 (1420)	67.7 (1720)
B	Wheel Base with Load Backrest	Raised		43.0 (1092)	48.9 (1242)	54.8 (1392)	66.6 (1692)
		Lowered		46.1 (1171)	52.0 (1321)	57.9 (1471)	69.7 (1770)
C	Overall Length without Load Backrest	–		57.8 (1468)	63.7 (1618)	69.6 (1768)	81.4 (2068)
C	Overall Length with Load Backrest	–		59.8 (1518)	65.7 (1669)	71.6 (1819)	71.7 (1821)
D	Chassis Length	–		22.4 (570)	22.4 (570)	22.4 (570)	22.4 (570)
OTR (b)	Outside Turning Radius (bumper) without Load Backrest	Raised		47.5 (1207)	53.4 (1356)	59.3 (1506)	71.2 (1808)
		Lowered		50.6 (1285)	56.5 (1435)	62.4 (1585)	74.2 (1885)
OTR (b)	Outside Turning Radius (bumper) with Load Backrest	Raised		49.5 (1257)	55.4 (1407)	61.3 (1557)	73.2 (1859)
		Lowered		52.6 (1336)	58.5 (1486)	64.4 (1636)	76.2 (1935)
OTR (h)	Outside Turning Radius (handle) without Load Backrest	Raised		48.9 (1243)	54.8 (1393)	60.7 (1623)	72.6 (1843)
		Lowered		52.1 (1323)	58.0 (1473)	63.9 (1623)	75.7 (1923)
OTR (h)	Outside Turning Radius (handle) with Load Backrest	Raised		50.9 (1293)	56.8 (1443)	62.7 (1593)	74.6 (1895)
		Lowered		54.1 (1374)	60.0 (1524)	65.9 (1674)	77.7 (1974)
E	Right Angle Stack (aisle) without Load Backrest	Raised		61.5 (1561)	66.3 (1685)	71.4 (1813)	81.8 (2077)
E	Right Angle Stack (aisle) with Load Backrest	Raised		63.2 (1605)	68.0 (1727)	73.0 (1854)	83.5 (2121)
F	Equal Intersecting Aisle without Load Backrest	–		52.5 (1334)	55.3 (1405)	58.4 (1484)	64.6 (1641)
F	Equal Intersecting Aisle with Load Backrest	–		53.2 (1351)	56.3 (1430)	59.4 (1509)	65.6 (1666)
W	% Grade Clearance ¹	Raised		67%	67%	67%	67%
X	% Grade Clearance ¹	Raised		36%	31%	27%	23%
Y	% Grade Clearance ¹	Raised		33%	33%	33%	33%

¹ Measured to the bottom of a GMA approved pallet on the forks while they are in the raised position.

BATTERY SPECIFICATIONS AND WEIGHTS

U.S. CUSTOMARY NUMBER OF CELLS	CELL SIZE	PLATES PER CELL	CAPACITY AMP-HOURS	(6 HR RATE) KWH	LENGTH (IN.)	WIDTH (IN.)	HEIGHT (IN.)	NOMINAL WEIGHT (LBS.)
GNB PalletPro® Battery Pack with 25 AMP Charger ▲			195	4.4	27.3	7.5	26.4	375
12	75	7	225	5.2	25.7	8.8	23.3	540
12	85	7	255	6.0	25.7	8.8	23.3	570
12	100	7	300	6.9	25.7	8.8	26.6	610

W50Z Pallet truck uses a 175 Amp Red Connector 20.0" (508 mm), 1/0 gauge leads, B position. Truck weight, total approx. without battery 553 lbs. (251 kg) ▲ GNB PalletPro requires a 1.5" (38.1mm) thick backplate spacer for proper positioning. Battery well 28.0" (712 mm) x 9.1" (232 mm) x open. Battery size is limited by rounded corners of battery compartment. Maximum battery width and length dimensions cannot be used in conjunction with each other. Please contact your local Hyster Dealer for more information and details.

GMA PALLET – STANDARD DIMENSIONS

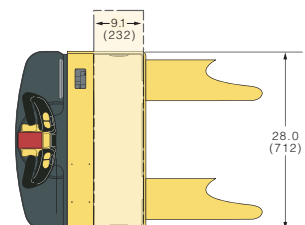
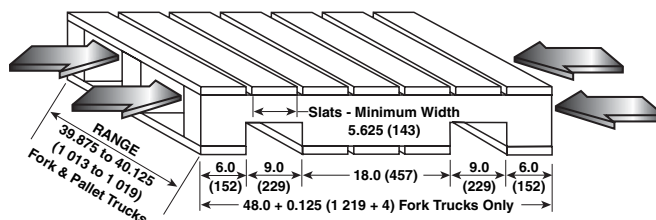

DIMENSIONS

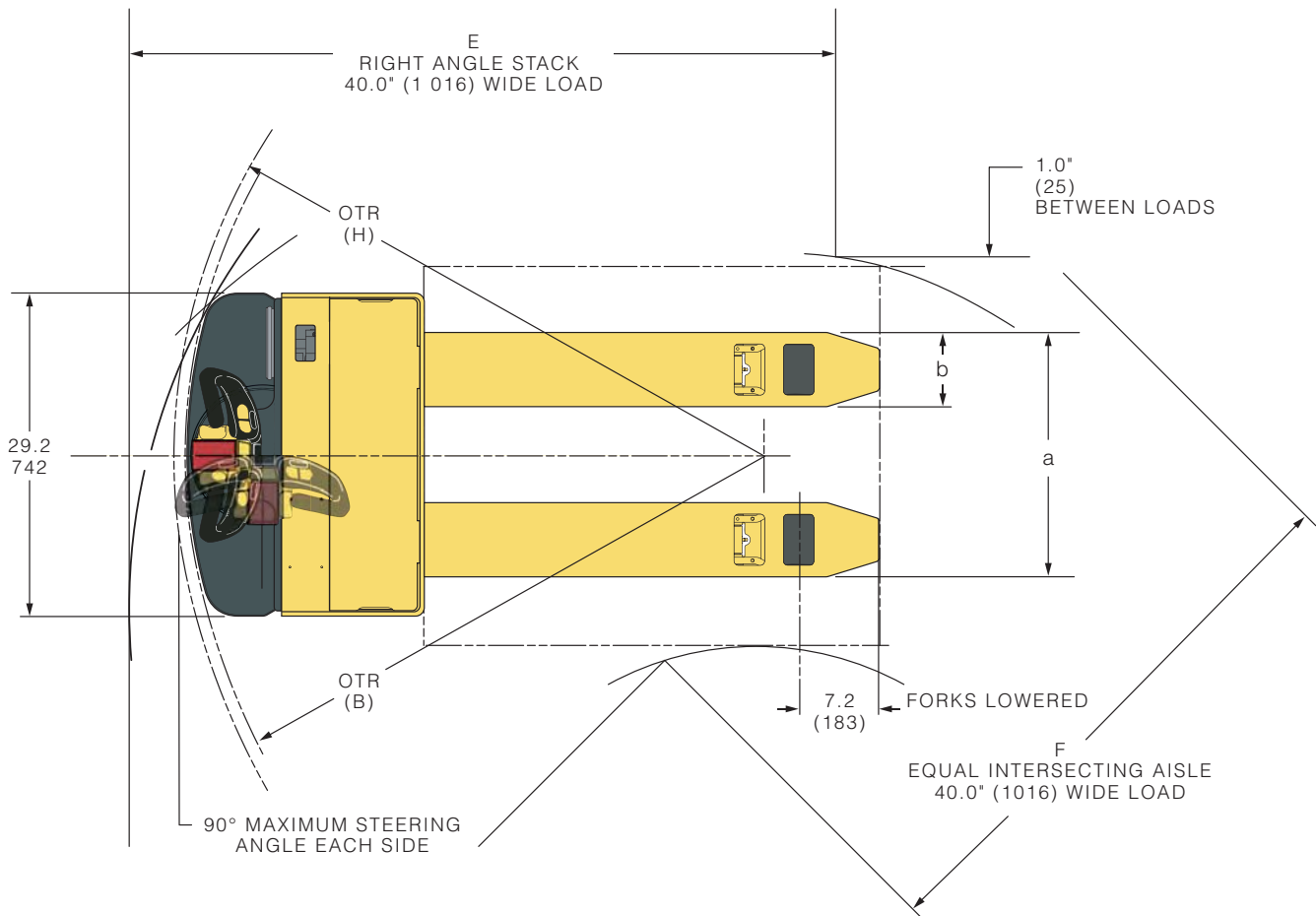
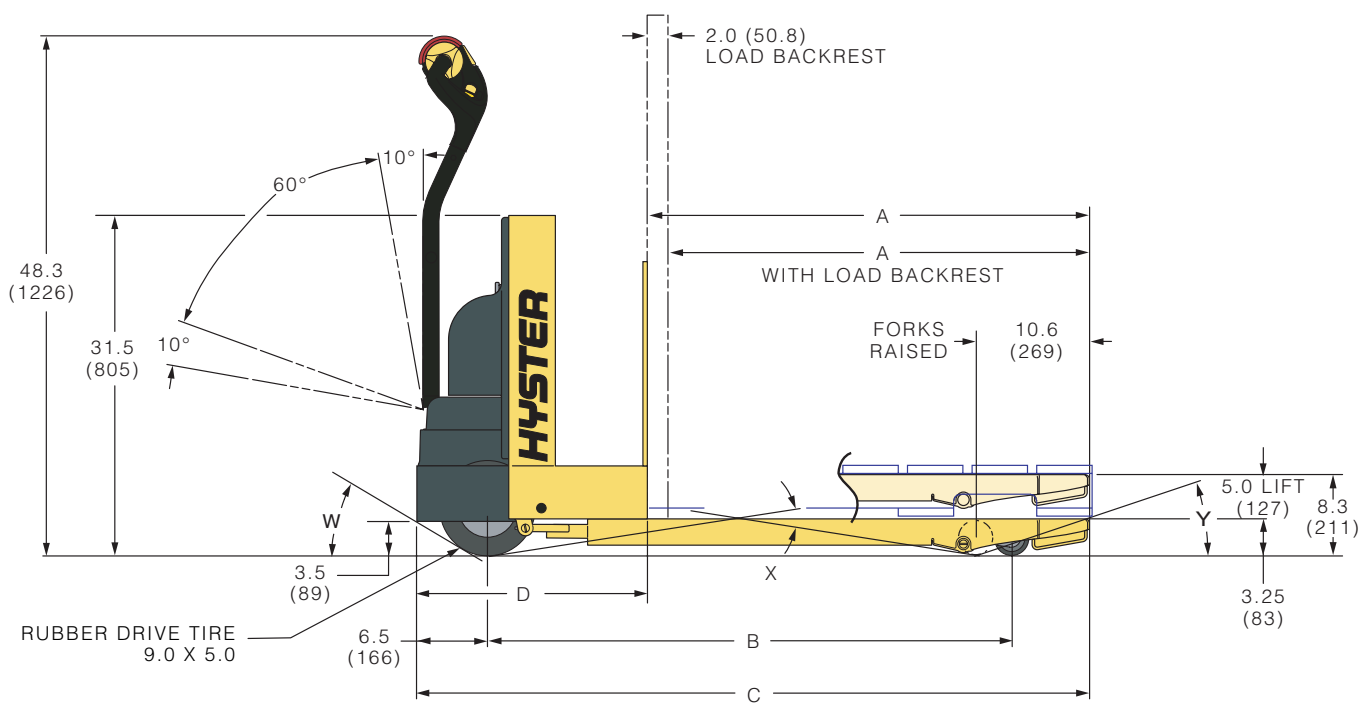

FEATURES



STANDARD

- 24 Volt
- SEM Transistor Control with Integrated Transistor Lift Pump Control
- 48" Long Forks
- 27" Fork Spread
- Low Battery Lift Interrupt
- Lift Motor Cut-out at Full Height
- Flush Pallet Stop
- Electromagnetic Park Brake with Service Override
- Regenerative Braking
- Press-on Rubber Drive Tire (9" x 5")
- Impact-Resistant, Ergonomically Designed, Bottom Mount Control Handle
- Direction Reversing Switch
- Creep Speed "Turtle" Button
- Three User Selectable Performance Modes
- Standard Operating Temperatures: +32° to +120° F

OPTIONAL

- Fork Lengths**
 - 36" Long Forks
 - 42" Long Forks
 - 60" Long Forks

- Fork Spread**
 - 18" Fork Spread
 - 22" Fork Spread

Note: Fork dimensions listed (length, spread, width) are nominal. See specifications page for actual dimensions.

- Load Backrest**
 - 48" High (Bolt-on)
 - 60" High (Bolt-on)

Application / Environmental Construction

Cooler / Freezer Package
Operating Temperatures:
0° to +120° F

SUBZERO Freezer Package
Operating Temperatures:
- 40° to +120° F

Extreme Corrosion / Wash Down Package
Operating Temperatures:
0° to 120° F

Includes Galvanized Frame, Lift Linkage, Battery Well, Fork Weldment and Sealed Load Wheel Bearings

USDA, EPA Friendly



Trucks shown with optional equipment.



FLEET SERVICES



HYSTER CAPITAL

A Division of NMHG Financial Services, Inc.

It's not just about the lift trucks.

Any company worth its weight knows success has just as much to do with the support before and after the sale as the sale itself. We pride ourselves on being more than just a lift truck manufacturer. Through our Dealer Network, we're also fleet managers, parts suppliers, capital procurement specialists and trainers. You'll find that when it comes to service, there's not much we don't do.

Hyster® Fleet Services

As much as we'd like for your entire fleet to be Hyster, we know that's not always the case. But just because you also operate other brands doesn't mean we can't manage your lift truck maintenance and replacement plan. We can analyze your current fleet or provide a summary of your fleet history and a cost-effective proposal for replacement and scheduled maintenance of all your vehicles. Once this initial review is complete, we'll continue to monitor your fleet to ensure it's performing optimally.

UNISOURCE™ Parts Program

In addition to providing fleet management for a variety of brands, we can also serve as your source of parts for all your lift trucks. With the Hyster UNISOURCE parts and service program, we offer approximately 2 million part number crosses for most brands of materials handling and other in-plant mobile equipment. UNISOURCE also has remanufactured parts that provide the same quality and guarantee but at a lower price. And we can deliver parts to you in less than 24 hours, any day of the week. How's that for convenience?

Rental Products

At Hyster Company, we're always looking for ways to help you keep your productivity up. Through the Hyster Dealer Network, you can access rental equipment for the times when leasing or buying isn't a practical option. Your local Hyster Dealer has access to over 14,000 units that are available for short- or long-term rental. Whether you need one truck to substitute for a vehicle that's being serviced or several lift trucks to accommodate seasonal changes in your business, we'll help you maintain output in a cost-effective manner.

Hyster® Capital

We know that financing new additions to your fleet can sometimes be challenging. That's why your Hyster Dealer has a long list of ways for you to fund your purchase. We are skilled in arranging solutions for special financing requirements, taking the difficulties out of buying the equipment you need. Whether you purchase or lease a new or used lift truck, Hyster Capital offers flexible service and competitive rates, ensuring you receive the value you deserve.

Special Products Engineering Department (SPED)

In a perfect world, every application could be handled with a standard lift truck. However, in the real world, different materials require different handling. That's why Hyster Company's Special Products Engineering Department works with you to customize* your lift trucks. From strobe lights to specially made forks, SPED can provide you with the tools you require to get the job done right.

* May be subject to an additional charge. Contact your local Authorized Hyster Dealer for more information.

Automated Warehouse Solutions

As society's technological capabilities advance, we strive to find practical applications. One of our most recent innovations in that pursuit is our development of automated warehouse solutions. We can help you determine if your operation would benefit from this type of system, which improves inventory accuracy, warehouse productivity and safety records, as it reduces maintenance and overtime.

Operator and Service Training

Hyster Company recognizes that proper training is a key element of a profitable company. That's why your local Authorized Hyster Dealer offers a training program for your lift truck operators as well as those who maintain your vehicles. Proper education in running and servicing lift trucks cuts down on the number of repairs and risk of injuries due to accidents while increasing productivity. All of our trainers are professionals with experience in materials handling.



Hyster Company
P.O. Box 7006
Greenville, North Carolina
27835-7006

Part No. W50Z/BTG
1/2006 Litho in U.S.A.

Visit us online at www.hysterusa.com or call us at 1-800-HYSTER-1.

Hyster and  are registered trademarks of Hyster Company. UNISOURCE is a trademark of Hyster Company. Hyster products are subject to change without notice. GNB PalletPro is a registered trademark of its respective company. ©2006 Hyster Company. All rights reserved.





WORLDWIDE





How important are your Walkie pallet trucks to your operation's success?

Hyster Company invites you to experience our evolutionary **W60Z Walkie pallet truck**. For over 70 years, Hyster Company has been building **lift trucks as tough as your business**, and our new W60Z pallet truck is no exception.

This new 6,000 lb. capacity walkie pallet truck delivers **excellent maneuverability, superior travel speeds** and the **versatility** your operations require. The W60Z truck's newly restyled bottom-mounted control handle affords you **increased comfort and control** for your busy work areas, crowded docks and trailers.

The W60Z truck's restyled bottom-mounted handle conveniently provides you control of all functions with either hand, including the horn. Its angle handgrips and bulbous head provide when-you-need-it protection for your fingers and knuckles. Also, its raised lift/lower buttons afford intuitive fingertip operation. The handle's traction reversing switch (belly switch) wraps the end of the handle, enabling actuation throughout its full range of pivot.



What's more, every W60Z Walkie pallet truck uses **proven Separately Excited Motor (SEM) transistor technology**, giving you the advantage of **programmability**, with the optional handset. SEM also saves you money by **simplifying** the W60Z Walkie's **maintenance needs**, by reducing parts. In addition, you get the added benefits associated with **regenerative braking** which include a significant increase in traction motor brush life and its corresponding lower maintenance costs. It also increases the traction motor's torque range providing increased travel speeds

The W60Z forks feature box-rail construction for increased strength and rigidity, throughout its full 6-inches of lift height. Adjustable two-piece heavy-duty pull rod assembly with replaceable threaded ends allow compensation as load wheels wear. Knock-out axles facilitate easy wheel replacement.





Optional display unit gives you battery state of charge, lift interrupt indication and status codes on an eight character LED screen.



bolstering your operation's productivity capabilities.

Can your operations use a **versatile, operator oriented workmate** as a building block for your fully integrated materials handling system? If so, let the industry leader, Hyster Company, show you the way to **higher productivity.**



Proven SEM technology and its advanced transistor controller and transistor hydraulics (standard) dramatically increase the W60Z Walkie pallet truck's energy efficiency. Which adds up to fewer battery replacements over the life of your Hyster walkie. And your operators will love the W60Z Walkie's enhanced transistor control system that gives smooth stepless acceleration, increased torque range, and regenerative braking. All of which lengthens brush motor life. SEM also permits the elimination of the 'extra' contactors, simplifying your truck's service needs. In addition, the current sensing feature of the transistor hydraulic's solid state control gives you end-of-stroke sensing with automatic motor shut down, lengthening motor life. All this gives you unmatched reliability, enhanced truck performance with less energy consumption, saving you time and money.

No more dents or cracks. The W60Z truck's resilient, high impact thermoplastic cover is tough enough to handle the rigors of your daily operations. The cover also uses spring clips instead of screws, so removal is a snap. And its low front bumper clearance (3.6 inches) prevents riding over pallets.



W60Z Walkie Pallet Truck Dimensions

GENERAL			Hyster Company	Hyster Company	Hyster Company
1	Manufacturer		Hyster Company	Hyster Company	Hyster Company
2	Model		W60Z	W60Z	W60Z
3	Capacity, rated	lb. (kg)	6,000 (2 700)	6,000 (2 700)	6,000 (2 700)
4	Voltage		24	24	24
DIMENSIONS					
5	Nominal fork length	in. (mm)	36.0 (915)	42.0 (1 067)	48.0 (1 219)
6	Width across forks	in. (mm)	27.0 (685)	27.0 (685)	27.0 (685)
7	Chassis length, with 13.4" battery compartment	in. (mm)	34.4 (874)	34.4 (874)	34.4 (874)
8	Overall length, with 13.4" battery compartment	in. (mm)	70.2 (1 783)	76.2 (1 935)	82.2 (2 087)
9	Wheelbase, lowered with 13.4" battery compartment	in. (mm)	53.8 (1 367)	59.8 (1 519)	65.8 (1 670)
	Wheelbase, raised with 13.4" battery compartment	in. (mm)	49.1 (1 247)	55.1 (1 400)	61.1 (1 551)
10	Turning radius, lowered, with 13.4" battery compartment	in. (mm)	63.2 (1 605)	69.2 (1 758)	75.2 (1 910)
	Turning radius, raised, with 13.4" battery compartment	in. (mm)	58.5 (1 485)	64.5 (1 638)	70.5 (1 790)
11	Right angle aisle stack, 13.4" batt. comp. w/ 40"x 48" pallet	in. (mm)	71.2 (1 808)	76.6 (1 946)	82.1 (2 096)
12	Equal intersecting aisle, 13.4" batt. comp. w/ 40.0" wide pallet	in. (mm)	56.5 (1 435)	59.8 (1 519)	62.9 (1 596)
13	Grade clearance, center wheelbase, raised with pallet	%	39	34	31
	Grade clearance, forks first, raised with pallet	%	39	39	39
	Grade clearance, chassis first, raised with pallet	%	42	42	42
14	Overall lift height (TOF)	in. (mm)	9.3 (236)	9.3 (236)	9.3 (236)
15	Overall fork lifting height	in. (mm)	6.0 (154)	6.0 (154)	6.0 (154)
BATTERY					
16	Battery compartment size, 13.4" batt. compartment (L x W x H)*	in.	32.0 x 13.4 x 31.0	32.0 x 13.4 x 31.0	32.0 x 13.4 x 31.0
	Battery compartment size, 13.4" batt. compartment (L x W x H)*	(mm)	(812 x 340 x 787)	(812 x 340 x 787)	(812 x 340 x 787)
18	Battery weight, 13.4" batt. compartment, 24-Volt - minimum	lb. (kg)	536 (243)	536 (243)	536 (243)
	Battery weight, 13.4" batt. compartment, 24-Volt - maximum	lb. (kg)	865 (392)	865 (392)	865 (392)
PERF †					
19	Travel speed, NL / RL	mph (km/h)	3.7 (6.0) / 2.6 (4.2)	3.7 (6.0) / 2.6 (4.2)	3.7 (6.0) / 2.6 (4.2)
20	Lift / lower speed, w/ 13.4" batt. compartment, 24-Volt NL	seconds	3.7 / 3.0	3.7 / 3.0	3.7 / 3.0
	Lift / lower speed, w/ 13.4" batt. compartment, 24-Volt RL	seconds	4.7 / 1.8	4.7 / 1.8	4.7 / 1.8
WHL					
21	Drive tire size (Rubber)	in.	10.0 x 5.0 x 6.5	10.0 x 5.0 x 6.5	10.0 x 5.0 x 6.5
22	Load wheel size, Single (Polyurethane)	in.	3.25 x 6.5	3.25 x 6.5	3.25 x 6.5
23	Weight, total approx. with 13.4" batt. compartment w/o battery	lb. (kg)	987 (448)	1,007 (457)	1,022 (464)
<p>* Length is measured side to side of truck. Width is measured front to back on the truck. W60Z Pallet Trucks use SB175 Red connector - 16.0" (406 mm) 1/0 gauge leads, B position. Number of plates for the industrial battery is 7 to 11, depending on the Amp Hour rating chosen. Maximum battery height with optional Load Backrest Extension (LBE) and battery rollers is 23.3" (592 mm). The W60Z Walkie pallet truck can utilize a battery with a maximum Amp hour capacity of 510 Ah (11.9 kw).</p>					

Certification: These Hyster lift trucks meet design specifications of Part II ANSI B56.1-1993, as required by OSHA Section 1910.178 (a) (2) and also comply with Part III ANSI B56.1-revision in effect at time of manufacture. Certification of compliance with the applicable ANSI standards appears on the lift truck.

† Note: Performance specifications are for truck equipped as described under Standard Equipment in this Technical Guide. Performance specifications are affected by the condition of the vehicle and how it is equipped, as well as by the nature and condition of the operating area. If these specifications are critical, the proposed application should be discussed with your dealers.

Optional load wheels affect outside turning radius and right angle stacking aisles. Contact your dealer if these dimensions are critical.

GMA Pallet - Standard Dimensions

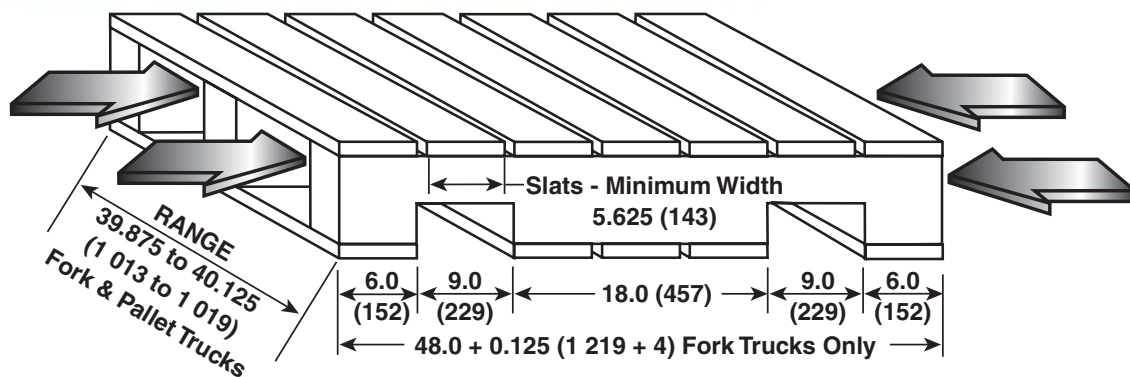



W60Z Walkie Pallet Truck Dimensions

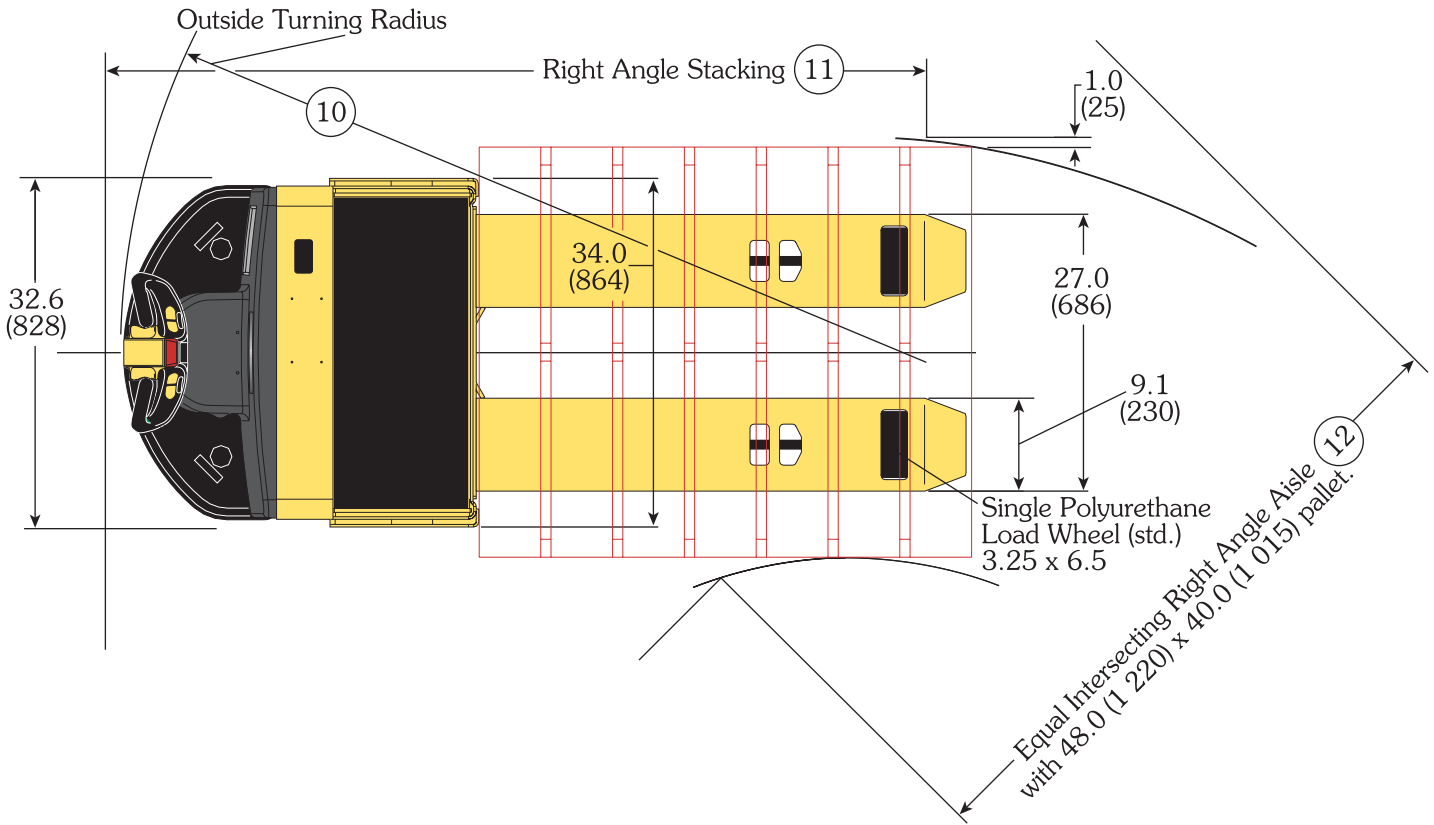

BATTERY SIZE INFORMATION							
Number	Cell	Plates	Capacity	Length	Width	Height	Weight
Cells	Size	Per Cell	Ah (Kwh)	in. (mm)	in. (mm)	in. (mm)	lbs. (kg)
12	75	7	225 (5.2)	25.6 (651)	8.8 (224)	23.3 (592)	536 (243)
12	85	7	255 (6.0)	25.5 (648)	8.6 (219)	23.3 (592)	590 (269)
12	75	11	375 (8.7)	26.5 (674)	13.0 (331)	23.3 (592)	825 (374)
12	85	11	425 (9.9)	26.1 (663)	12.8 (326)	23.3 (592)	865 (392)

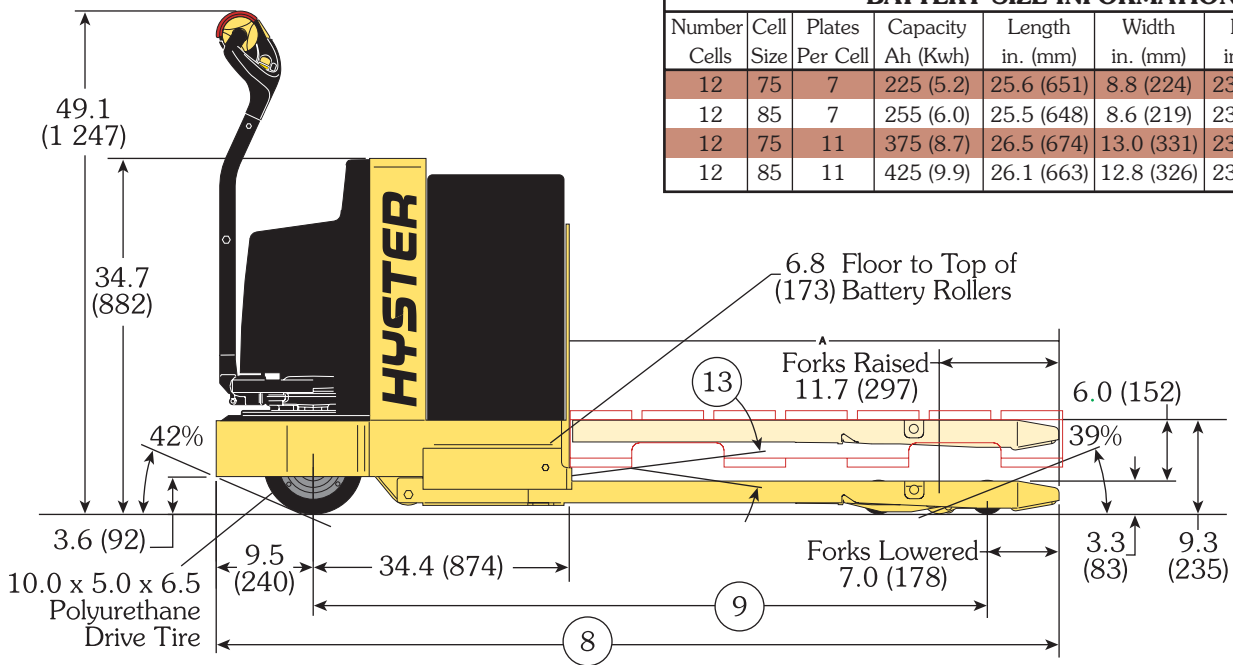

Circled dimensions correspond to the line numbers on the tabulated charts. Dimensions are in inches (millimeters).

TRUCKS AS TOUGH AS YOUR BUSINESS



Standard equipment includes:

- 24 Volt • SEM traction controller • Low battery lift interrupt • Lift motor cut-out at full height • 13.4" Battery Compartment
- Flush pallet stop • 48.0" Forks • Electronic horn • Regenerative braking • Electromagnetic park brake • 27.0" width across forks
- SB 175 Red battery connector • 3.25" Lowered fork height with 6.0" lift height • Key switch • Traction reversing switch
- Knock-out load wheel axles • Heavy-duty pull rods with replaceable threaded ends • Single polyurethane load wheels
- 10.0" x 5.0" Rubber drive tire • Butterfly-type accelerator control • Bottom mounted control handle • Operator's manual
- U.L. Classification E.



Hyster Company
P.O. Box 7006
Greenville, North Carolina
27835-7006

Part No. W60Z/BTG
9/2002 Litho in U.S.A.

Visit us on our website: www.hysterusa.com

Hyster, , VISTA and MONOTROL are registered trademarks of Hyster Company. XM XM₂ and XMT₂ are trademarks of Hyster Company. Hyster products are subject to change without notice.



Hyster Company uses recycled paper for its sales literature.





WORLD CLASS



Hyster Company's low level materials handling equipment comes full-circle with the evolutionary W65Z Walkie Pallet Truck.



The many benefits of Hyster Company's heritage are clearly revealed in the well planned design and meticulous assembly of our evolutionary **W65Z Walkie Pallet Truck**. Its technically advanced yet uniquely appealing capabilities will ensure its smooth integration into your existing 12-volt operations.

Equipped with one of three optional environmental packages: **cooler/freezer/food processing**, the W65Z Walkie will easily handle capacity loads in a number of applications. The **sealed componentry of the food processing package** keeps out the moisture of hot-water wash-down. From the first turn of the key, this pallet truck's balanced design **delivers greater maneuverability and operator comfort**.

Comforts like, its restyled bottom-mounted handle that provides excellent control of all functions with either hand including the horn. Or, perhaps it's the butterfly-type rotary controls and raised lift and lower buttons that afford you **intuitive fingertip operation**.



Both are literally topped by the W65Z Walkie handle's traction reversing "belly" switch which wraps over the



top end, enabling actuation throughout its full range of motion. In addition, the control handle's raised body design provides protection for your knuckles. And you'll love, the **optional creep speed or "turtle" button** on the operator side of the handle. It allows operation of the truck, even when the handle's in the upright position. Best of all, the handle's modular design makes servicing simple.

Since our engineers have provided you a way out of those 'tight spots', we felt it only right to simplify pallet access to further **bolster your productivity**. The W65Z pallet truck's fork profile has been re-designed with a tapered nose and shortened pallet exit skid. In addition, we used a wider exit roller and moved it closer to the load wheel. Both design enhancements help ensure **easier entry and exit from any pallet**, loaded or unload. What's more, the W65Z Walkie's full 6-inches of lift height makes traveling across uneven floors and over dockboards or ramps **hassle-free**. Handling capacity loads every time isn't a problem, the **box-section construction** of the W65Z truck's forks provide unmatched durability and strength.





W65Z Walkie Pallet Truck Dimensions

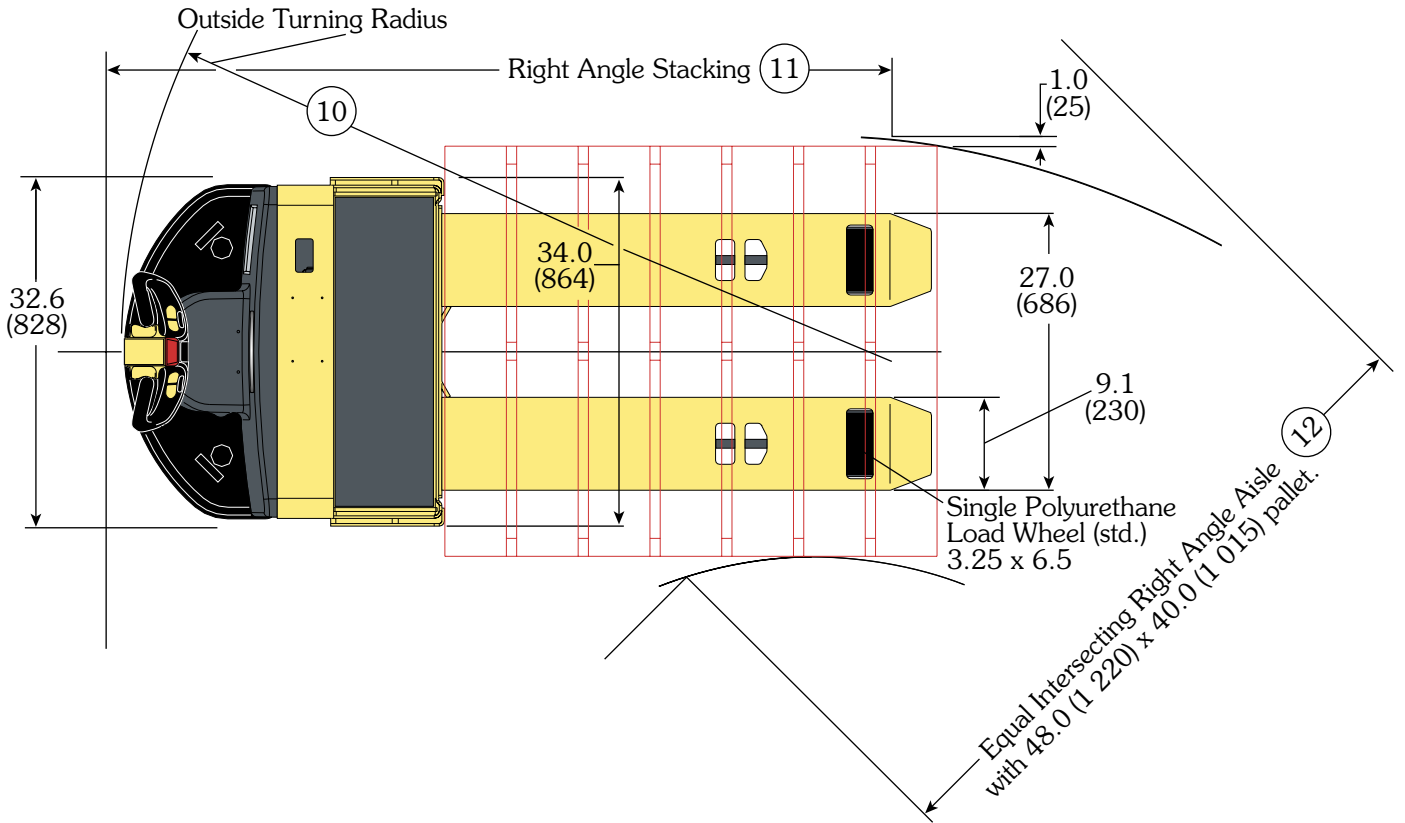

BATTERY SIZE INFORMATION							
Number Cells	Cell Size	Plates Per Cell	Capacity Ah (Kwh)	Length in. (mm)	Width in. (mm)	Height in. (mm)	Weight lbs. (kg)
6	85	7	255 (2.5)	18.8 (478)	6.8 (173)	23.0 (584)	305 (130)
6	85	11	425 (5.0)	26.1 (663)	7.7 (196)	23.3 (592)	436 (198)
6	85	13	510 (6.0)	30.6 (777)	7.7 (196)	23.3 (592)	511 (232)
6	125	13	750 (8.8)	30.6 (777)	7.7 (196)	31.0 (787)	710 (322)

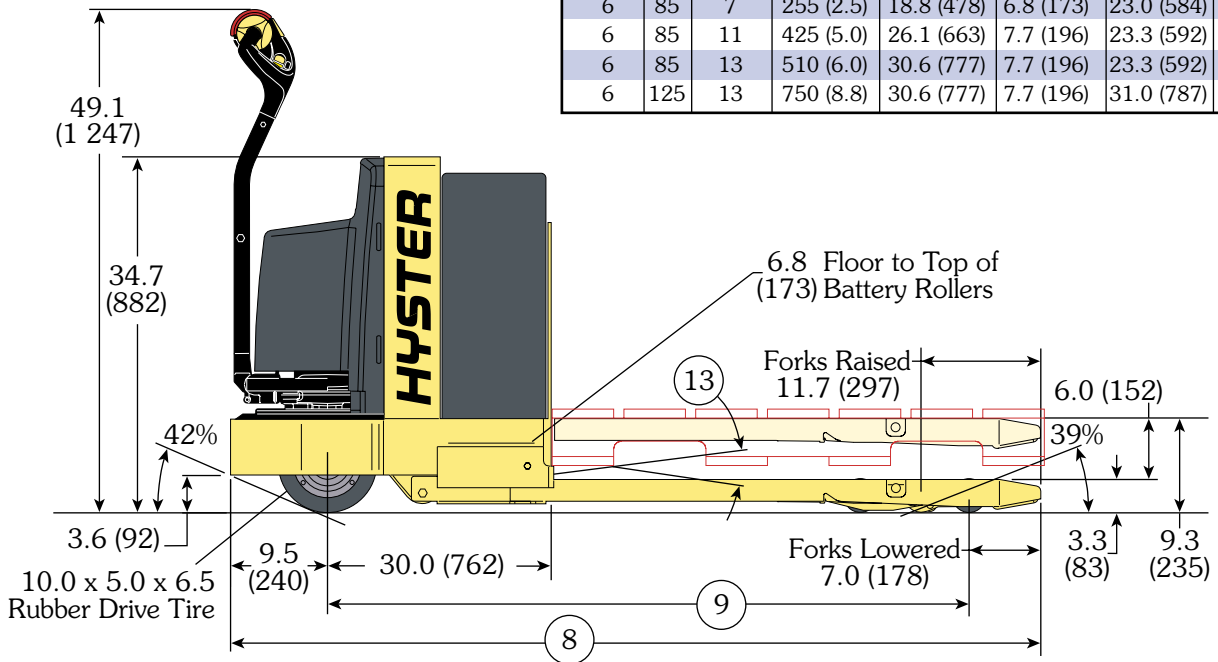

Circled dimensions correspond to the line numbers on the tabulated charts. Dimensions are in inches (millimeters).



W65Z Walkie Pallet Truck Specifications

GENERAL		Hyster Company	Hyster Company	Hyster Company
1	Manufacturer	Hyster Company	Hyster Company	Hyster Company
2	Model	W65Z	W65Z	W65Z
3	Capacity, rated lb. (kg)	6,500 (2 948)	6,500 (2 948)	6,500 (2 948)
4	Voltage	12	12	12
DIMENSIONS				
5	Nominal fork length in. (mm)	36.0 (915)	42.0 (1 067)	48.0 (1 219)
6	Width across forks in. (mm)	27.0 (685)	27.0 (685)	27.0 (685)
7	Chassis length, with 9.0" battery compartment in. (mm)	30.0 (762)	30.0 (762)	30.0 (762)
8	Overall length, with 9.0" battery compartment in. (mm)	65.8 (1 671)	71.8 (1 824)	77.8 (1 976)
9	Wheelbase, lowered with 9.0" battery compartment in. (mm)	49.4 (1 255)	55.4 (1 407)	61.4 (1 560)
	Wheelbase, raised with 9.0" battery compartment in. (mm)	44.7 (1 1350)	50.7 (1 288)	56.7 (1 440)
10	Turning radius, lowered, with 9.0" battery compartment in. (mm)	58.8 (1 494)	64.8 (1 646)	70.8 (1 798)
	Turning radius, raised, with 9.0" battery compartment in. (mm)	54.1 (1 374)	60.1 (1 527)	66.1 (1 679)
11	Right angle aisle, 9.0" batt. comp. w/ 40"x 48" pallet in. (mm)	67.3 (1 709)	72.6 (1 844)	78.0 (1 981)
12	Equal intersecting aisle, 9.0" batt. comp. w/ 40.0" wide pallet in. (mm)	54.3 (1 379)	57.5 (1 461)	60.6 (1 539)
13	Grade clearance, center wheelbase, raised with pallet %	44	38	34
	Grade clearance, forks first, raised with pallet %	39	39	39
	Grade clearance, chassis first, raised with pallet %	42	42	42
14	Overall lift height (TOF) in. (mm)	9.3 (236)	9.3 (236)	9.3 (236)
15	Overall fork lifting height in. (mm)	6.0 (154)	6.0 (154)	6.0 (154)
BATTERY				
16	Battery compartment size, 9.0" batt. compartment (L x W x H) * in.	32.0 x 9.0 x 31.0	32.0 x 9.0 x 31.0	32.0 x 9.0 x 31.0
	Battery compartment size, 9.0" batt. compartment (L x W x H) * (mm)	(812 x 229 x 787)	(812 x 229 x 787)	(812 x 229 x 787)
18	Battery weight, 9.0" batt. compartment, 12-Volt - minimum lb. (kg)	305 (130)	305 (130)	305 (130)
	Battery weight, 9.0" batt. compartment, 12-Volt - maximum lb. (kg)	710 (322)	710 (322)	710 (322)
PERF †				
19	Travel speed, NL / RL mph (km/h)	3.6 (5.7) / 2.6 (4.2)	3.6 (5.7) / 2.6 (4.2)	3.6 (5.7) / 2.6 (4.2)
20	Lift / lower speed, w/ 9.0" batt. compartment, 12-Volt NL seconds	3.8 / 5.1	3.8 / 5.1	3.8 / 5.1
	Lift / lower speed, w/ 9.0" batt. compartment, 12-Volt RL seconds	5.7 / 3.0	5.7 / 3.0	5.7 / 3.0
WHL				
21	Drive tire size (Rubber) in.	10.0 x 5.0	10.0 x 5.0	10.0 x 5.0
22	Load wheel size, Single (Polyurethane) in.	3.25 x 6.5	3.25 x 6.5	3.25 x 6.5
23	Weight, total approx. with 9.0" batt. compartment w/o battery lb. (kg)	936 (425)	963 (437)	990 (450)
<p>* Length is measured side to side of truck. Width is measured front to back on the truck. W65Z Pallet Trucks use SB175 Yellow connector - 20.0" (508 mm) 1/0 gauge leads, B position. Number of plates for the industrial battery is 7 to 13, depending on the Amp Hour rating chosen. Maximum battery height with optional Load Backrest Extension (LBE) and battery rollers is up to 31.0" (787). The W65Z Walkie Pallet Truck can utilize a battery with a maximum battery Amp hour of 750 Ah (17.8 kwh).</p>				

Certification: These Hyster lift trucks meet design specifications of Part II ANSI B56.1-1993, as required by OSHA Section 1910.178 (a) (2) and also comply with Part III ANSI B56.1-revision in effect at time of manufacture. Certification of compliance with the applicable ANSI standards appears on the lift truck.

† **Note:** Performance specifications are for truck equipped as described under **Standard Equipment** in this Technical Guide. Performance specifications are affected by the condition of the vehicle and how it is equipped, as well as by the nature and condition of the operating area. If these specifications are critical, the proposed application should be discussed with your dealers.

Optional load wheels affect outside turning radius and right angle stacking aisles. Contact your dealer if these dimensions are critical.

GMA Pallet - Standard Dimensions

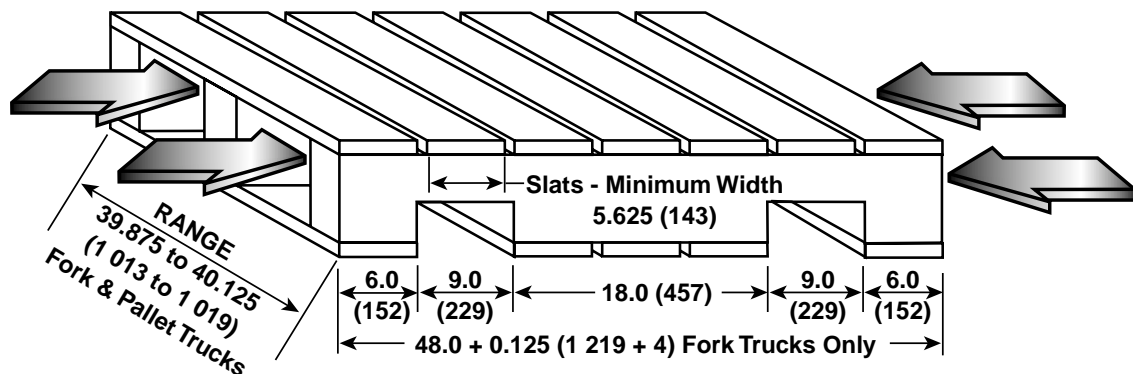

The **W65Z Walkie Pallet Truck** is equipped with the proven technology of Separately Excited Motor (SEM) with transistor controls and hydraulics, giving you **unsurpassed energy efficiency**. The solid-state transistor controls, circuit boards, and microprocessor significantly reduce the number of parts, wires and couplings on this evolutionary Walkie Pallet Truck, **maximizing your uptime**. The transistor controls also dramatically increase the life of the traction motor brushes, **minimizing servicing needs** even further. Another bonus of the W65Z Walkie Pallet Truck's integral solid-state transistor hydraulic



Performance at a glance. Optional display unit gives you battery state of charge, and status codes on an 8-character LCD screen. What's more, the clipboard clip comes standard to help keep your paperwork or lists within easy reach.



controls is the current sensing feature built into the controller. It provides you **end-of-stroke sensing with automatic motor shut down** that considerably lengthens motor life. Best of all, the energy efficiency of both the SEM system and transistor hydraulic control adds up to **fewer battery replacements** over the life of your W65Z Walkie trucks. The W65Z is just another great example of Hyster Company's commitment to continually earn your trust with **materials handling equipment targeted to your operation's needs**.

The W65Z truck's have adjustable two-piece heavy-duty pull rod assemblies with replaceable threaded ends. This combination allows you easy height compensation as the load wheels wear. It also has knock-out axles that facilitate quick and easy wheel replacement to maximize your uptime.



Removeable battery retention plates and optional pivoting load backrest extension (LBE) secure the W65Z truck's battery when you choose to equip your W65Z with the optional battery rollers. The LBE comes in either 48" or 60" heights to maximize your load handling capabilities.

HYSTER. IN FOR THE LONG RUN.



Standard equipment includes:

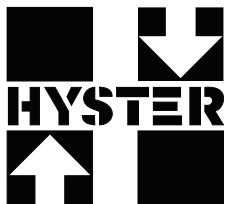

- 12 Volt • SEM traction controller • Low battery lift interrupt • Lift motor cut-out at full height • 9.0" Battery Compartment
- Flush pallet stop • Electronic horn • Regenerative braking • 27.0" Width across forks • Single polyurethane load wheels
- 3.3" Lowered fork height with 6.0" lift height • 48.0" Long forks • Electromagnetic park brake • Knock-out load wheel axles
- SB 175 Yellow battery connector • Key switch • Heavy-duty pull rods with replaceable threaded ends • Traction reversing switch
- Top mounted control handle • Operator's manual • Butterfly-type accelerator control • 10.0" x 5.0" Rubber drive tire
- U.L. Classification E.



Hyster Company
P.O. Box 7006
Greenville, North Carolina
27835-7006

Part No. W65Z/BTG
3/2003 Litho in U.S.A.

Visit us on our website: www.hysterusa.com

Hyster, , VISTA and MONOTROL are registered trademarks of Hyster Company. XM, XM₂, XMT₂ and  UNISOURCE are trademarks of Hyster Company. Hyster products are subject to change without notice.



Hyster Company uses recycled paper for its sales literature.





W
8
0
N



When was the last time you felt great about a capital purchase?

You will, the first time you operate the new **W80Z Walkie Pallet Truck**. It's designed to fit into those tight spaces. You know the ones where you place everything you didn't need right then, but you need it now . . . **Infused with the integrity** of over 70 years of materials handling manufacturing expertise, this new Walkie Pallet Truck has what it takes to move your operations productivity to the next level. And as the lift truck industry's only full line **ISO-9001 certified lift truck manufacturer** in the world, quality is built-in . . . guaranteed.



The W80Z Pallet Truck shown is equipped with the optional load backrest extension and convenience tray for pick tickets, a roll of tape, pens, even a bar-code scanner.



The SEM transistor controller's current sensing feature provides you end-of-lift-stroke sensing with automatic motor shut down, lengthening motor life.

What's most important to you?

The W80Z Walkie truck's **energy efficient**, Separately Excited Motor (SEM) transistor controlled 24-volt system of the W80Z Walkie gives you the endurance to get the job done, and then some. SEM technology allows us to provide you a Walkie pallet truck with fewer parts to **minimize downtime** and service needs. It also affords you **regenerative braking** capabilities, significantly increasing SEM motor brush life. In addition, the SEM systems solid-state controller **appreciably improves torque and loaded travel speed** throughout the W80Z truck's range of operation, increasing productivity. And if you have a harsh environment, you'll love our **optional Cooler/Freezer, SUBZERO or Extreme Corrosion/Wash Down packages**.





W80Z Walkie Pallet Truck Dimensions

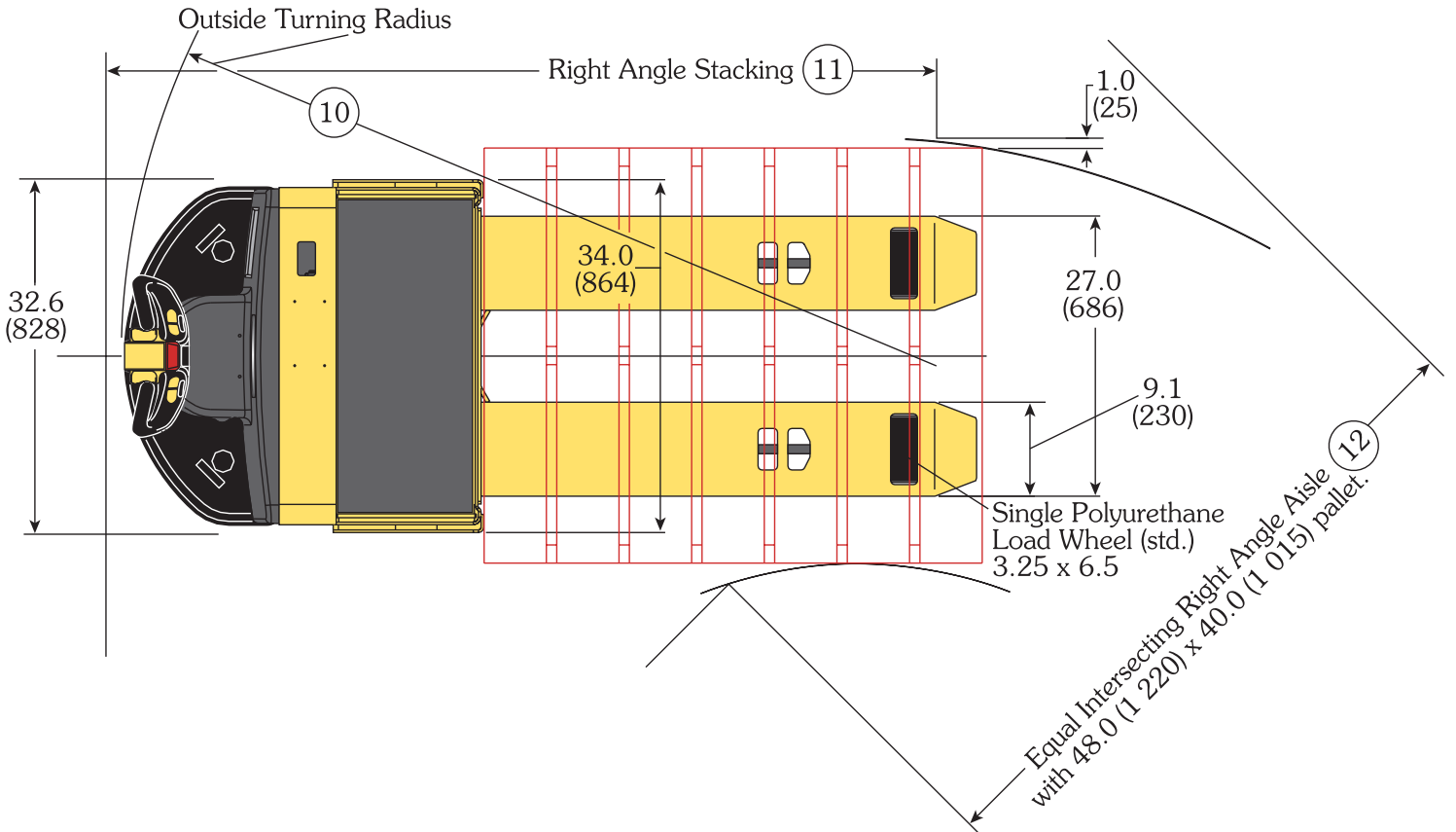

BATTERY SIZE INFORMATION							
Number Cells	Cell Size	Plates Per Cell	Capacity Ah (Kwh)	Length in. (mm)	Width in. (mm)	Height in. (mm)	Weight lbs. (kg)
12	75	7	225 (5.2)	25.6 (651)	8.8 (224)	23.3 (592)	536 (243)
12	85	7	255 (6.0)	25.5 (648)	8.6 (219)	23.3 (592)	590 (269)
12	75	11	375 (8.7)	26.5 (674)	13.0 (331)	23.3 (592)	825 (374)
12	85	11	425 (9.9)	26.1 (663)	12.8 (326)	23.3 (592)	865 (392)
12	75	13	450 (10.5)	30.9 (785)	13.0 (681)	23.3 (592)	987 (448)
12	85	13	510 (11.9)	30.9 (785)	13.0 (681)	23.3 (592)	1,035 (469)
12	100	13	600 (14.0)	30.9 (785)	13.0 (681)	26.2 (665)	1,140 (517)

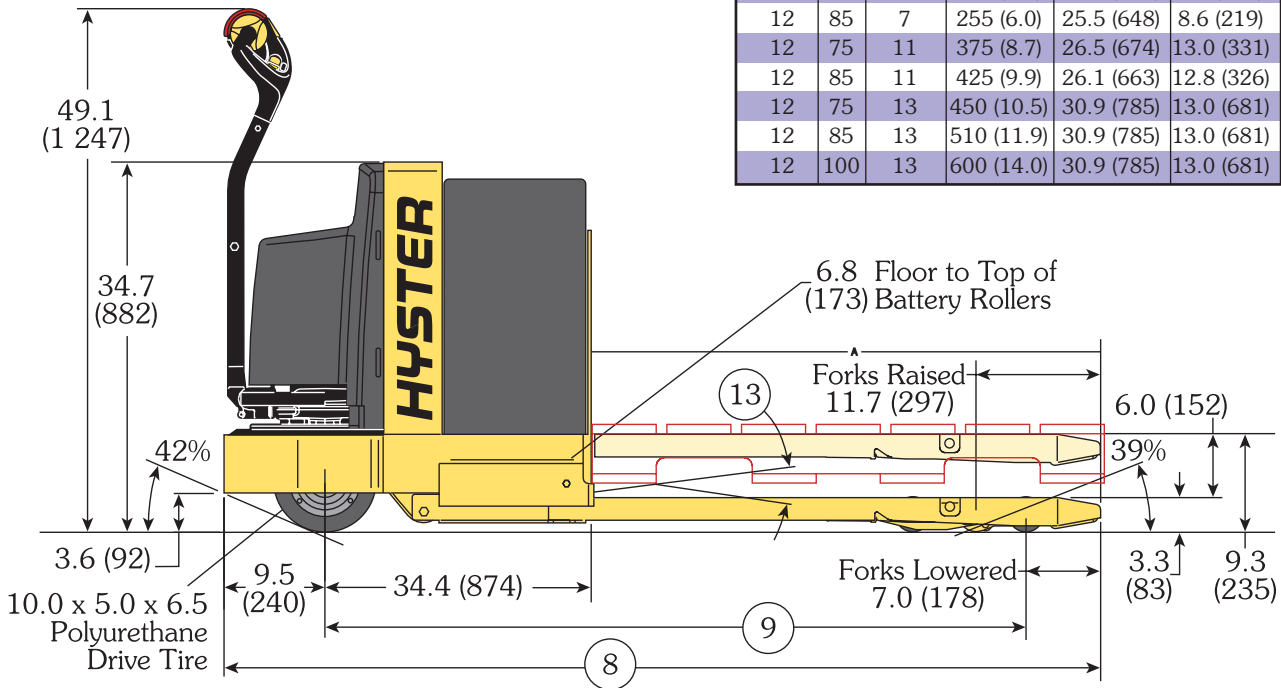

Circled dimensions correspond to the line numbers on the tabulated charts. Dimensions are in inches (millimeters).



W80Z Walkie Pallet Truck Specifications

GENERAL		Hyster Company	Hyster Company	Hyster Company
1	Manufacturer	Hyster Company	Hyster Company	Hyster Company
2	Model	W80Z	W80Z	W80Z
3	Capacity, rated lb. (kg)	8,000 (3 628)	8,000 (3 628)	8,000 (3 628)
4	Voltage	24	24	24
DIMENSIONS				
5	Nominal fork length in. (mm)	36.0 (915)	42.0 (1 067)	48.0 (1 219)
6	Width across forks in. (mm)	27.0 (685)	27.0 (685)	27.0 (685)
7	Chassis length, with 13.4" battery compartment in. (mm)	34.4 (874)	34.4 (874)	34.4 (874)
8	Overall length, with 13.4" battery compartment in. (mm)	70.2 (1 783)	76.2 (1 935)	82.2 (2 087)
9	Wheelbase, lowered with 13.4" battery compartment in. (mm)	53.8 (1 367)	59.8 (1 519)	65.8 (1 670)
	Wheelbase, raised with 13.4" battery compartment in. (mm)	49.1 (1 247)	55.1 (1 400)	61.1 (1 551)
10	Turning radius, lowered, with 13.4" battery compartment in. (mm)	63.2 (1 605)	69.2 (1 758)	75.2 (1 910)
	Turning radius, raised, with 13.4" battery compartment in. (mm)	58.5 (1 485)	64.5 (1 638)	70.5 (1 790)
11	Right angle aisle, 13.4" batt. comp. w/ 40"x 48" pallet in. (mm)	71.2 (1 808)	76.6 (1 946)	82.1 (2 096)
12	Equal intersecting aisle, 13.4" batt. comp. w/ 40.0" wide pallet in. (mm)	56.5 (1 435)	59.8 (1 519)	62.9 (1 596)
	Grade clearance, center wheelbase, raised with pallet %	39	34	31
	Grade clearance, forks first, raised with pallet %	39	39	39
	Grade clearance, chassis first, raised with pallet %	42	42	42
14	Overall lift height (TOF) in. (mm)	9.3 (236)	9.3 (236)	9.3 (236)
15	Overall fork lifting height in. (mm)	6.0 (154)	6.0 (154)	6.0 (154)
BATTERY				
16	Battery compartment size, 13.4" batt. compartment (L x W x H)* in.	32.0 x 13.4 x 31.0	32.0 x 13.4 x 31.0	32.0 x 13.4 x 31.0
	Battery compartment size, 13.4" batt. compartment (L x W x H)* (mm)	(812 x 340 x 787)	(812 x 340 x 787)	(812 x 340 x 787)
18	Battery weight, 13.4" batt. compartment, 24-Volt - minimum lb. (kg)	536 (243)	536 (243)	536 (227)
	Battery weight, 13.4" batt. compartment, 24-Volt - maximum lb. (kg)	1,140 (517)	1,140 (517)	1,140 (517)
PERF †				
19	Travel speed, NL / RL mph (km/h)	3.6 (5.8) / 2.4 (3.9)	3.6 (5.8) / 2.4 (3.9)	3.6 (5.8) / 2.4 (3.9)
20	Lift / lower speed, w/ 13.4" batt. compartment, 24-Volt NL seconds	3.7 / 5.9	3.7 / 5.9	3.7 / 5.9
	Lift / lower speed, w/ 13.4" batt. compartment, 24-Volt RL seconds	5.4 / 3.2	5.4 / 3.2	5.4 / 3.2
WHL				
21	Drive tire size (Polyurethane) in.	10.0 x 5.0	10.0 x 5.0	10.0 x 5.0
22	Load wheel size, Single (Polyurethane) in.	3.25 x 6.5	3.25 x 6.5	3.25 x 6.5
23	Weight, total approx. with 13.4" batt. compartment w/o battery lb. (kg)	1,006 (456)	1,033 (468)	1,060 (480)
<p>* Length is measured side to side of truck. Width is measured front to back on the truck. W80Z Pallet Trucks use 175 Amp Red connector - 16.0" (406 mm) 1/0 gauge leads, B position. Number of plates for the industrial battery is 7 to 13, depending on the Amp Hour rating chosen. Maximum battery height with optional Load Backrest Extension (LBE) and battery rollers is up to 31.0" (787mm). The W80Z Walkie pallet truck can utilize a battery with a maximum battery Amp hours of 600 Ah (14.0 kw).</p>				

Certification: These Hyster lift trucks meet design specifications of Part II ANSI B56.1-1993, as required by OSHA Section 1910.178 (a) (2) and also comply with Part III ANSI B56.1-revision in effect at time of manufacture. Certification of compliance with the applicable ANSI standards appears on the lift truck.

† Note: Performance specifications are for truck equipped as described under **Standard Equipment** in this Technical Guide. Performance specifications are affected by the condition of the vehicle and how it is equipped, as well as by the nature and condition of the operating area. If these specifications are critical, the proposed application should be discussed with your dealers.

Optional load wheels affect outside turning radius and right angle stacking aisles. Contact your dealer if these dimensions are critical.

GMA Pallet - Standard Dimensions

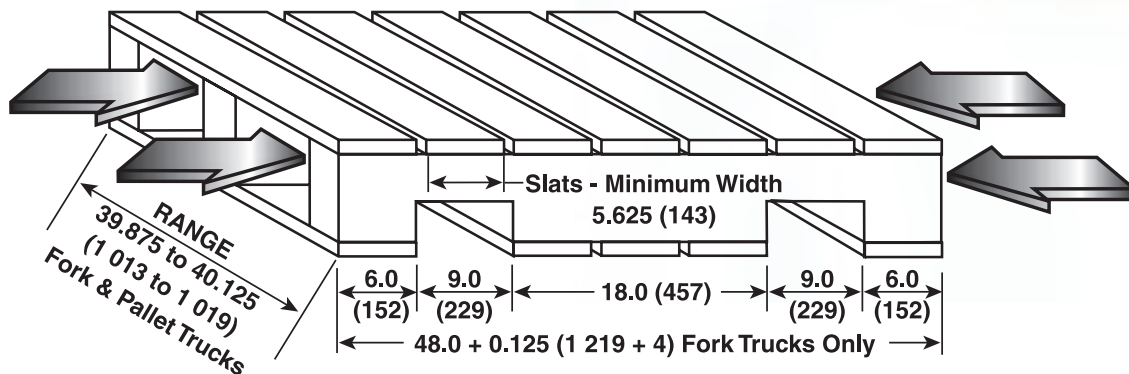

Efficient load handling.

Designed to maximize your operation's low-level order picking and palletized load handling capabilities, the new W80Z truck's **pallet entry/exit system** with exit rollers allows you to get into and out of loads quicker and easier. Built with

box-rail construction, the W80Z forks provide

you ample strength and rigidity throughout its **full**

6-inches of lift height. Best of all, the

adjustable 2-piece heavy-duty pull rod assembly

utilizes replaceable threaded ends, allowing you to compensate for load wheel wear. Knock-out axles simplify load wheel replacement, helping to **maximize your uptime**.



The W80Z truck's restyled bottom-mounted handle provides you fingertip control of all functions, with either hand. You'll love the new optional Creep Speed "Turtle" button (brake override), located just below the red direction reversing switch that wraps the end of the handle. It allows you to move the truck with the handle in its full-upright position, to get you into and out of tight spots.



The W80Z Walkie Pallet Truck is shown equipped with the optional display that gives you battery state of charge, truck hours, lift interrupt warning and status codes on an eight character LCD screen.

RAISING THE STANDARDS.



Standard equipment includes:

- 24 Volt • SEM traction controller • Low battery lift interrupt • Lift motor cut-out at full height • 13.4" Battery Compartment
- Flush pallet stop • 48.0" Forks • Electronic horn • Regenerative braking • Electromagnetic park brake • 27.0" width across forks
- 175 Amp Red battery connector • 3.25" lowered fork height with 6.0" lift height • Key switch • Direction reverse switch
- Knock-out load wheel axles • Heavy-duty pull rods with replaceable threaded ends • Single polyurethane load wheels
- 10.0" x 5.0" Polyurethane drive tire • Butterfly-type accelerator control • Bottom mounted control handle • Operator's manual
- U.L. Classification E.





Hyster Company

P.O. Box 7006
Greenville, North Carolina
27835-7006

Part No. W80Z/BTG

2/2006 Litho in U.S.A.

Visit us on our website: www.hysterusa.com.

Hyster, , SpaceSaver, VISTA and MONOTROL are registered trademarks of Hyster Company. Fortis, DuraMatch, Pacesetter VSM, TouchPoint, TouchControl, Challenger, and  are trademarks of Hyster Company. Hyster products are subject to change without notice.

