

Counter Balanced Truck FB-70 Series 35/40/45

● Standard Specifications

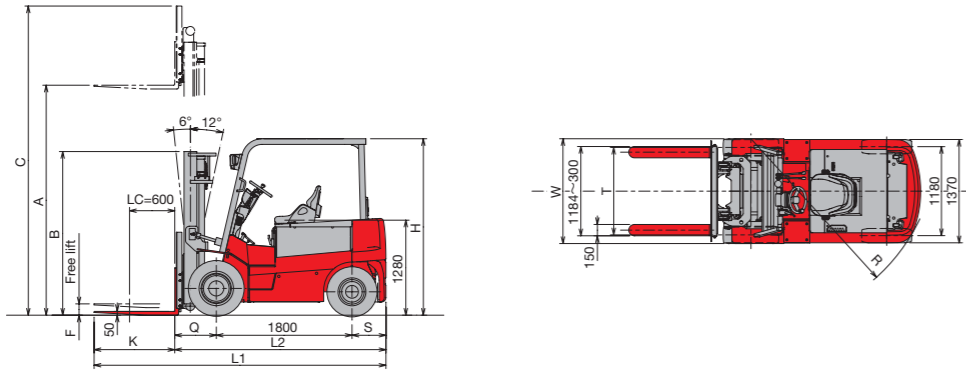

Model		FB-70 Series				
		FB35P	FB40P	FB45PN		
Performance	Capacity	kg	4000	4500		
	Load Center	mm	600			
	Lifting Height	A mm	3000			
	Free Lift	F mm	150			
	Lift Speed	Laden	mm/s	320	300	
		Unladen	mm/s	480	400	
	Travel Speed	Laden	km/h	14.0	13.5	
		Unladen	km/h	16.0	15.0	
	Min. Turning Radius *	R mm	2510	2530		
	Min. 90° Turning Aisle **	mm	2410	2430		
Gradeability (Laden/unladen)	%	15/18	13/16			
Dimensions	Overall Length	L1 mm	3870	3910		
		L2 mm	2800	2840		
	Overall Width	W mm	1390			
	Overall Height	Overheadguard	H mm	2340		
		Mast Lowered	B mm	2170	2250	
		Mast Extended	C mm	4050		
	Fork L × T × W	K mm	1070×50×150			
	Wheelbase	mm	1800			
	Road Clearance	mm	150 (Mast)			
	Front Overhang	Q mm	550	565		
Rear Overhang	S mm	450	475			
Tread	Front	T mm	1160			
	Rear	mm	1180			
Service Weight (W/O Battery)	kg	5040	5310	5870		
Tyres	Front		250-15-18PR	250-15 SOLID		
	Rear		7.00-12-12PR	7.00-12 SOLID		
Control System		Inverter Control (Traction, Hydraulic, Power Steering)				
Motors	Traction	kW	14.0			
	Hydraulic	kW	20.0			
	Power Steering	kW	1.8			
Voltage	V	72				
Battery	Capacity	Standard	Ah	545	600	600
		Optional	5HR	600	—	—
	Battery Weight (Min./Max.)			1200/1330	1300/1330	1300/1330
Charger (Option)		Automatic Stationary Charger (3-phase, 200 V)				
Capacity	KVA	12		16		

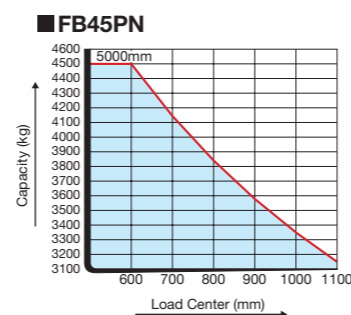
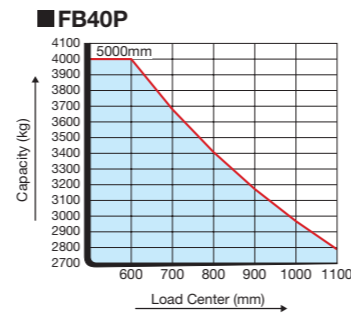
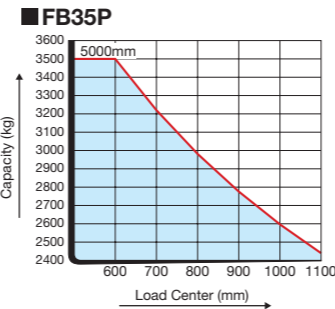

* No clearance included
** 1100×1100 pallet, no clearance included

ECO-LOGISTICS since 1937
NICHYU
NIPPON YUSOKI CO., LTD.

1-1, 2-chome, Higashikotari, Nagaokakyo-shi, Kyoto 617-8585 Japan
Phone: +81-75-956-8622 Fax: +81-75-955-0480
URL: <http://www.nichiyunet.co.jp/>



All specifications are confirmed based on manufacturer's terms and conditions.
All specifications are subject to change without notice in the interest of continued improvement or modifications.

CAT. No. 075-1, 5000/0704/(SK) Printed in Japan
Printed on 100% recycled paper.

NICHYU ELECTRIC LIFT TRUCKS



NICHYU COUNTER BALANCED TRUCK



FB-70 Series 35/40/45

Counter Balanced Type

3.5/4.0/4.5 tons

The eco-friendly electric forklift that's quiet, comfortable, and — above all — clean.



Smooth and Reliable

The SICOS-AC super-intelligent control system ensures powerful and highly efficient operation.

We've reduced maintenance costs by 20%.

The AC motor eliminates the need for brushes and contactors.

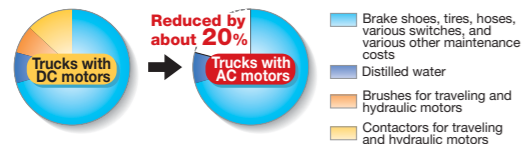

Smooth & Powerful Operation

Very precise speed control is possible. It dramatically improves inching operation.

Quieter Operation

We've significantly reduced noise caused by motor brushes, fans, and the control chopper.

IPX3 rating waterproof design

Thanks to the IPX3 waterproof design, it can be used outdoors on rainy days. It is impervious even to wind-driven rain falling at a 60° angle.



Multiple regenerative functions recover waste energy.

- Coasting** ... Recovers when you lift your foot off the accelerator.
- Plugging** ... Recovers when you reverse the direction of travel (forward/reverse).
- Braking** ... Recovers when you activate the footbrake.
- Speed suppression on downslopes** ... Recovers when you coast on a downslope.

Significantly Increased Speed for Traveling and Lifting

Traveling speed	Previous model	→	New model
	12.0km/h		16.0km/h
Lifting speed	Previous model	→	New model
	310mm/sec		480mm/sec

※Data: FB40P at P-mode, Unladen

Safety Cruise

This feature prevents sudden sliding down even if the both of accelerator and brake pedals are released. What's more, it limits the vehicle to a safe speed when traveling on a downslope.

Speed is limited to about 1 km/h (anti roll back) when the both of accelerator and brake are released on an upslope. Maintains a safe speed on downslopes. (Speed suppression on downslopes)



Safe and Comfortable

Small Turning Radius

With this compact design, we've significantly reduced the front overhang and achieved the smallest turning radius. This innovation contributes to enhanced efficiency and ease of operation.

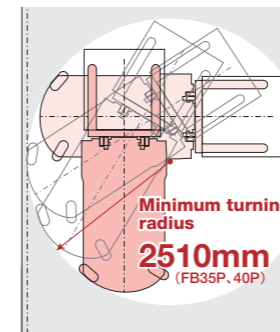

Comfortable Operation

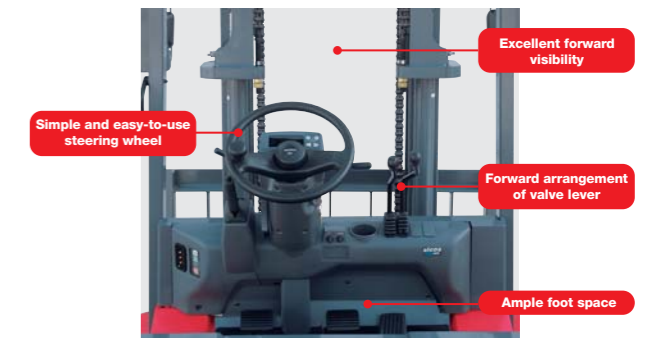

Clear display shows complete operating status at-a-glance

In addition to showing vehicle speed and remaining battery capacity, the multidisplay unit allows you to make a variety of settings.

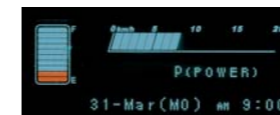

Basic display



Self-diagnosis display



Driving-mode setting display

Wide, Convenient Steps

The two wide steps offer greater ease and convenience.



Open-type Mast

The three-stage mast and two-stage full-free mast are open type offering excellent visibility.

※ The three-stage mast and two-stage full-free mast options are not available with Model FB45PN.



Laser Pointer (optional)

The red laser beam serves as a handy guide for fork positioning.



Load Indicator (optional)

With this feature, the load weight is displayed on the display, preventing overloading for enhanced safety.

※Note: The scale is not intended for use in legal trade.

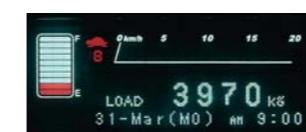

Operation Interlock System

For operator's safety, travel and mast operations are automatically interlocked when the operator is not properly seated for more than two seconds.



※ The brake cannot be activated. Set the parking brake when leaving the vehicle.

Simplified Maintenance

The fully opening battery cover incorporates a locking gas spring for easier battery inspection and maintenance.

