

adaptalift **GROUP**

**Yale**<sup>®</sup>   
People. Products. Productivity.

# VX Veracitor Series

GDP/GLP40-55VX | 4,000 - 5,500 kg

Pneumatic Tyres Counterbalanced Forklift



**13 23 20**

[www.adaptalift.com.au](http://www.adaptalift.com.au)

## The True Solution

# The Yale Veracitor VX Series

Yale has invested heavily in people, processes and capital equipment to deliver this innovative series of internal combustion engine lift trucks. Each lift truck in the Veracitor VX range has been designed with component commonality, for simplified operational maintenance and bespoke productivity packages, to meet specific customer needs. Each lift truck demonstrates Yale's total commitment to innovative design, comprehensive testing, high quality, advanced components and superior manufacturing.

The company's leadership in the materials handling sector has been achieved through extensive research among existing and prospective customers, lift truck operators and experts in ergonomics and biometrics. The Yale Veracitor VX Series offers dependability, productivity, comfort for operators and real value for customers through an impressively low cost of ownership. That's why each Yale Veracitor VX lift truck represents a true solution to today's materials handling needs.



### TRUTH N°1

Our innovative cooling system enables dramatically lower operating temperatures and much longer running times.





# True Dependability

# Reliability

Yale Veracitor VX lift trucks are designed and manufactured to be the most dependable in today's market. That dependability is not only in evidence throughout the Veracitor VX Series, but also in Yale's expert advice, 24 hours parts availability and the most comprehensive warranty coverage in the industry. The Veracitor VX Series can reduce downtime by up to 30% and world-class reliability is achieved in four key areas.

## Powertrain

The reliable, rugged powertrain delivers exceptional durability through its computer-controlled engine and transmission, its tough clutch packs and remarkably robust gears and shafts. Long term durability is achieved by enhanced monitoring and the optional Powertrain Protection Systems which, for example, eliminate high speed power reversal. The engines offer low emissions as well as easy maintenance access.

## Reducing Wear and Tear

Yale has raised the standards in lift truck serviceability and the Veracitor VX has the highest serviceability ratings in the industry. The Veracitor VX offers reliable electronics and sealed connectors, allowing the entire truck to be pressure washed. Hall effect sensors have solid-state components that are magnetically operated and are 100% sealed from the environment.

## Innovative Cooling System

The cooling system operates at lower temperatures. This offers significant improvement when it comes to cooling air flow, increasing component life and minimising the risk of overheating in heavy-duty applications. Optimised ducting and high volume tunnels allow Veracitor VX lift trucks to run longer in a cooler state. Radiators are 100% shock-mounted for long life.

O-ring face seals on all high pressure hydraulic connections eliminate the need for thread sealants creating leak-free joints. A superior filtration system increases the life span of all hydraulic components.



Sealed Electrical Connectors



## TRUTH N°2

Continuous Stability Enhancement (CSE) improves lateral stability and boosts driver confidence.

## Intellix Vehicle System Manager (VSM)

This innovative, highly advanced on-board computer is, essentially, the sort of electronic management system that is extensively used in the automotive industry. It controls the engine and transmission by monitoring and protecting the lift truck.

A sensitive computer like this needs protection, so it is environmentally sealed to keep out water and debris.

Furthermore, CANbus electronics reduce the complexity of the wiring, which have been routed well away from all heat sources.

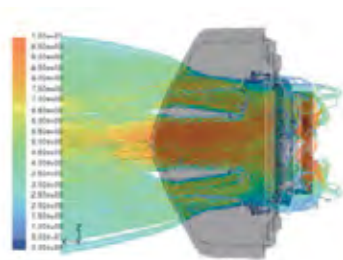

Maximised air flow for enhanced cooling



Combi-Cooler Radiator used on 4000kg-5500kg Models



O-ring face seals on all high pressure, hydraulic connections

# True Productivity Performance

Every single facet of each Veracitor VX lift truck has been designed to boost performance and to increase productivity. This is true of all Veracitor VX configurations. What's more, the Yale Veracitor VX models have been designed to meet, and exceed, your specific application requirements. The Yale Veracitor VX Series productivity cost savings are achieved through lower lift truck operating expenses, reduced labour costs, reduced operator overtime expense and additional savings from increased throughput.

Yale Veracitor VX lift trucks out-performed the major competition on an identical test cycle. The combination of engine and transmission options allows our lift trucks to be tailored to your specific applications.

The Yale 4000kg - 5500kg Productivity lift truck delivers maximum performance in heavy-duty applications. The Yale Value lift truck provides excellent performance for medium to heavy-duty applications and is optimised for the lowest hourly cost of operation. The Yale Base lift truck offers first-rate performance for light to medium-duty applications and is geared to minimise your cost of acquisition, without compromising performance.

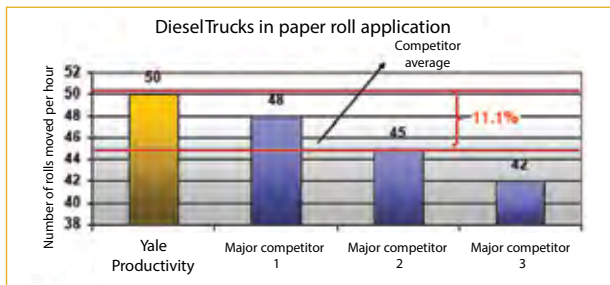

### Three Engine Options

The Yale 4000kg - 5500kg Veracitor VX Series has three engine options to provide application flexibility with outstanding operating costs.

<b>LP Gas Engine</b>	GM 4.3L
<b>Diesel Engines</b>	Kubota 3.6 L, Kubota 3.8 L

### TRUTH N°3

Intellix VSM (Vehicle System Manager) maximises driver efficiency and reduces downtime.

### Four Transmission Options Available

#### Standard Electronic Powershift

One speed or Two speed forward/one speed reverse

#### Techtronix 100

One speed forward/One speed reverse

#### Techtronix 100X

Two speed forward/One speed reverse

#### Techtronix 200X

Two speed forward/One speed reverse

All of these transmissions feature smooth electronic inching, electronic shift and neutral start/brake interlock.

### TRUTH N°4

The Auto Deceleration System (ADS) and the Dynamic Auto Deceleration System (DADS) reduces brake usage, leading to fewer brake shoe replacements, and lower service costs.

### Techtronix 100 and 100X transmissions

These two transmissions maximise the advantages of **Auto Deceleration System (ADS)**. This feature slows the truck automatically without the operator needing to use the footbrake. It can be programmed to suit the operator or the application requirements, reducing operator fatigue and reducing brake shoe wear which, in turn, lowers truck operating costs.

### Controlled Power Reversal (CPR)

A unique feature that prevents the operator from spinning the tyres when changing direction whilst the engine is at full throttle. This feature removes all dynamic powertrain stress, whilst delivering cost savings on fuel consumption and expensive tyre replacements.

Controlled Roll-Back. (CRB). A controlled ramp descent feature that limits truck rollback to 75mm per second. This feature is particularly important when loading and unloading on gradients or inclines.

### Techtronic 200X transmission

This transmission provides all the functionality of the 100 and 100X transmissions with the additional enhanced features.



### **Auto speed hydraulics (ASH)**

Engine speed automatically increases independent of any operator intervention to provide full hydraulic power to the hoist function while the travel speed remains constant.

### **Dynamic Auto Deceleration System (DADS)**

This allows the operator to reduce the speed of the truck without using the brake. The rate of braking is determined by the programmable dashboard settings 1-10. The rate of deceleration can be controlled further by the rate at which the operator releases his foot from the accelerator pedal.

### **Throttle Response Management (TRM)**

This allows the operator to control travel speed according to the position of his foot on the accelerator pedal. This provides him with the ability to maintain the required travel speed on a gradient without the need to depress or release the accelerator pedal.

### **Extended Draw Bar Pull**

Available in first gear, particularly useful when fully laden and significant and frequent gradients are encountered. Second gear provides maximum engine efficiency for applications where longer travel distances are required.

### **Continuous Stability Enhancement system (CSE)**

This system enhances each lift truck's lateral stability with a simple, maintenance-free design that does not compromise uneven surface travel.





# True Comfort

## Intelligent Ergonomics

The truth of the matter is that operators prefer Veracitor VX lift trucks. Results from an independent survey of a representative sample of lift truck operators confirm this.\* Comfort is enhanced due to the innovative design of the operator's compartment.

The isolated powertrain and Full Suspension Seat provide best in class Whole-Body Vibration levels of  $0.6m/s^2$ , helping to reduce fatigue, aches and pains and ensuring that the operator remains comfortable and productive. Excellent operator visibility is afforded through the Yale Hi-Vis™ mast and Command

Driving Position. Other key features include: the optimised step height, increased shoulder clearance, easy right-sided access and ergonomically designed controls.

Rear driving comfort has been improved with a convenient, rear drive handle complete with horn button, optimally placed on the rear overhead guard leg. The rear drive handle, in conjunction with an optional swivel seat, creates a comfortable and secure working environment. A smaller steering wheel and the infinitely adjustable steer column accommodate operators of all sizes.

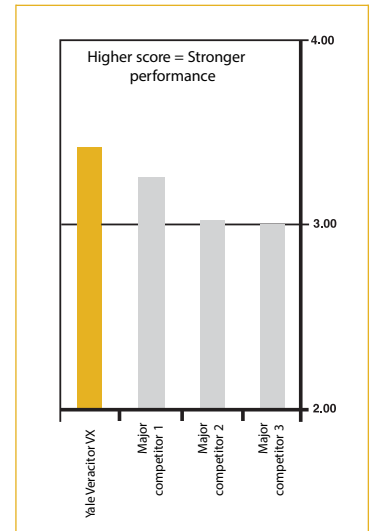

\*Source: Ergonomic Centre of North Carolina, USA.

### TRUTH N°5

Intellix VSM (Vehicle System Manager) is a diagnostic computer that maximises uptime by monitoring and protecting all key functions.

Low step height provides easy entry and exit. The standard cowl-mounted, manual hydraulic levers offered on the Base Models also allow easy access for right-side entry/exit. Yale Accutouch mini levers are offered as an option on the base model. Yale's rounded overhead guard design provides extra shoulder entry and headroom.



### Hydraulic Control Lever Options

The Yale Accutouch, electro-hydraulic control option offers excellent ergonomic design with shorter reach and throw levers. This means that considerably less effort is required for operation, compared to manual hydraulic levers. The fully adjustable armrest is contoured for maximum comfort and flexibility and minimum muscle and joint strain and - in addition to the hydraulic functions - features a horn and direction switch, ensuring that all key truck functions are within constant, easy reach.

### Auto Deceleration System and Dynamic Auto Deceleration System

The Auto Deceleration System (ADS), which is standard on the Yale Techtronix 100 and 100X transmissions, reduces brake pedal usage and subsequently operator leg fatigue.

It is programmable via the operators dash display.

The Dynamic Auto Deceleration System (DADS) performs in the same way and is programmable through the dash display. It is controlled by the operator and activated by the release of the accelerator pedal, the braking affect being directly proportional to the accelerator pedal position.

### EZ - LP Gas Tank Bracket

The optional EZ-Tank Bracket is an added feature on the standard swing-out bracket. The LP tank swings out and drops down approximately 60 degrees for effortless removal and installation.

# True Value

## Low Cost of Ownership

The purchase price of a lift truck is only a small part of the overall cost. Cost of ownership accounts for the largest portion of expenditure and this includes such elements as periodic maintenance, unscheduled repairs, tyres, brakes and fuel costs.

Yale engineers focused on delivering customer cost savings with additional engine and transmission options, increased hydraulic efficiency and world-class serviceability.

The Veracitor VX Value truck offers substantial operating cost savings over the competition.

The world-class dependability of the Veracitor VX Series has reduced the cost to operate these lift trucks through a selection of rugged powertrain configurations, radiator design, reliable electronics and truly exceptional hydraulics.

The Techtronix transmissions offer improved tyre and fuel costs through controlled direction changes. Yale's engine options contribute to reduced operating costs.

The GM 4.3L LP Gas engine, in conjunction with the Kubota 3.6L and 3.8L Diesel engines, delivers outstanding fuel economy, with competitive performance.

The available Load Sensing Hydraulics system delivers increased operational efficiency, as the engine only supplies power to the hydraulic pumps when required. This delivers increased responsiveness and acceleration, which helps to maximise productivity and lower fuel consumption, reducing overall operating costs.

Intellix VSM, the smart Vehicle System Manager, maximises driver efficiency by managing fast direction changes that reduce tyre spin and wear. Intellix VSM maximises uptime by monitoring and protecting key lift truck functions.

### TRUTH N°6

Our Robust Clutch Packs last three times longer than normal clutch systems – saving you time and money.





Brake life is significantly improved with the Auto Deceleration System (ADS), a standard feature on the Techtronix 100 and 100X, and the Dynamic Auto Deceleration System (DADS), standard on the Techtronix 200X. These features automatically slow the lift truck when the throttle pedal is released. This action minimises brake usage requirement and operator fatigue, whilst reducing associated brake costs.

Oil immersed brakes are standard on the 4000 - 5500 kg trucks. They further contribute to lowering operating costs by virtually eliminating brake maintenance. These long life brakes are fully sealed against contamination making them ideal for tough and demanding environments.

The Controlled Power Reversal (CPR) system is a unique feature that prevents the operator from spinning the tyres when changing direction whilst the engine is at full throttle. This feature removes all dynamic powertrain stress, whilst delivering cost savings on fuel consumption and expensive tyre replacements.

Yale has improved the serviceability of the Veracitor VX Series – reducing the labour costs associated with periodic maintenance and unscheduled repairs. Veracitor VX lift trucks offer best in class service access with a one-piece, rear-opening hood providing cowl-to-counterweight access. An easy to remove floor plate requires no tools and offers complete access to the powertrain. Simplified daily checks and reduced service requirements result in lower maintenance costs.

### TRUTH N°7

The unique Techtronix Transmission provides controlled power reversal, virtually eliminating tyre spin, prolonging tyre life and reducing fuel costs.



# True Serviceability

The Veracitor VX Series has been designed to be extremely easy to service as well as requiring less maintenance. From the rear-opening, one-piece hood and on-board diagnostics, to the most comprehensive parts availability in the industry, the Veracitor VX sets new standards in lift truck serviceability.

By utilising cutting edge technology and superior manufacturing facilities, Yale engineers have delivered the highest serviceability ratings in the industry. This chart represents the Society of Automotive Engineers (SAE) based rating, evaluating speed and difficulty of over 30 service routines. A lower score indicates easier serviceability.

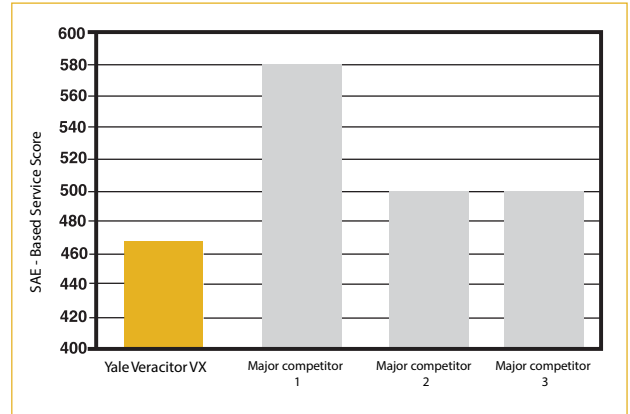

## Maximum Access

The Veracitor VX has a rear-opening, one-piece hood that opens an impressive 75 degrees. Coupled with the one-piece floor plate, it provides excellent cowl-to-counterweight access. All engine compartment daily checks are located on the same side of the lift truck for quick identification and access.

The uncluttered layout under the hood offers clean hydraulic and electrical routings.

The radiator is easy to access and the filler cap and optional radiator lint screen can be removed without the use of tools. The coolant recovery bottle is easily visible to check levels. A coolant fill neck is located so that it's easy to reach.

The Intellix VSM, Vehicle Systems Manager continuously monitors lift truck functions and immediately alerts the operator to any service needs. Extensive on-board diagnostics on the advanced dash display

communicates service codes, enabling quick and accurate repairs. PC-based diagnostics also enable fast and precise troubleshooting facilitating first-time fixes.

Yale has reduced regular service requirements on the Veracitor VX and automatic electronic inching eliminates the need for periodic adjustment. The Auto Deceleration System (ADS) and the Dynamic Auto Deceleration system (DADS) reduces brake usage, leading to decreased brake maintenance and shoe replacement. Oil immersed brakes contribute to reduced cost of operation. All these reductions in lift truck service, reduce cost and improve profitability.

The Yale difference can be summed up in one, highly successful formula, which clearly illustrates why every Veracitor VX in the range is a truly remarkable lift truck.



## TRUTH N°8

We offer the most reliable and comprehensive parts program available in the industry, maximising your productivity.

# Veracitor VX Series

## Choices and Versatility

The Veracitor VX Series is available in three configurations to meet and exceed your material handling application requirements.  
(Application guideline only)



Lift Truck Type	Base	Value	Productivity
Design Objective	lowest acquisition cost	minimum cost per hour	max. loads moved per hour
Lift Truck Usage	8 - 15 hours per day	16 - 24 hours per day	12 - 24 hours per day
Ramp Usage	frequent	frequent/steep	intensive
Extended Drawbar Pull	none	minimum	maximum
Hydraulic Attachments	sideshift/fork positioner	attachment usage	high attachment usage
Lift Height	less than 3500mm	3500mm - 4500mm	more than 4572mm
Grade Capability	less than 5%	5% - 10%	more than 10%
Environment	clean/dry	variable	variable
Load Capacity	general type	variable loads	frequently near capacity

### Engine option overview

Model	Capacity	Base		Value		Productivity	
		Diesel	LPG	Diesel	LPG	Diesel	LPG
		Kubota	GM	Kubota	GM	Kubota	GM
40VX	4000kg	3.6L	4.3L	3.8L	4.3L	3.8L	4.3L
45VX	4500kg	3.6L	4.3L	3.8L	4.3L	3.8L	4.3L
50VX	5000kg	3.6L	4.3L	3.8L	4.3L	3.8L	4.3L
55VX	5500kg	3.6L	4.3L	3.8L	4.3L	3.8L	4.3L



# Veracitor VX Series

## Choices and Versatility

Engines	Transmissions	Hydraulic Control
<p>LP Gas</p> <p>GM 4.3L Power = 77kW @ 2400rpm Torque = 305Nm @ 2400rpm Max rpm 2400</p> <p>Diesel</p> <p>Kubota 3.6L* Power = 57kW @ 2200rpm Torque = 296Nm @ 1400rpm Max rpm 2400</p> <p>Kubota 3.8L** Power = 55kW @ 2200rpm Torque = 309Nm @ 1400rpm Max rpm 2200</p> <p><i>*Kubota V3600 Diesel engine is only available in territories with category 1 diesel fuel, which contains sulphur levels of over 500ppm. This engine is not compatible with (&lt;500ppm) or Ultra-Low (&lt;15ppm) sulphur diesel fuel.</i></p> <p><i>**Kubota V3800 3.8L Diesel engine is equipped with a cooled EGR system, which requires the use of Low (&lt;500ppm) or Ultra-Low (&lt;15ppm) sulphur fuel.</i></p>	<p>Standard Electronic 1 or 2-speed Powershift* Base Model One or Two speed Electronic shift control. Smooth hydraulic inching. Neutral start switch. Anti-restart protection. Premium wet brakes.</p> <p><i>*The Standard Electronic Powershift transmission engine is available with Kubota V3600 only.</i></p> <p>Techtronix 100 Value Model One-speed. Heavy-duty clutch packs. Electronic inching. Auto Deceleration System (ADS). Controlled Power Reversal (CPR). Controlled Roll-back (CRB). Standard wet brakes.</p> <p>Techtronix 100X Value Model All Features of Techtronix 100. Two-speed auto shift - (2 x forward / 1 x reverse). Extended Draw Bar Pull (EDBP). Standard or Premium wet brakes.</p> <p>Techtronix 200X Productivity Model All Features of Techtronix 100 and 100X. Two-speed auto shift-(2 x forward 1 x reverse). Dynamic Auto Deceleration System (DADS). Throttle Response Management (TRM). Auto Speed Hydraulics (ASH). Premium wet brakes.</p>	<p>Base Model Manual cowl mounted levers - Standard. Easy-reach ergonomic design. Excellent right-side access.</p> <p>Option - E-Hydraulic Accutouch mini-lever, Fingertip activation, Best-in-class comfort</p> <p>Value Model E-Hydraulic Accutouch mini lever - Standard, Fingertip activation, Best-in-class comfort. Excellent right-side access.</p> <p>Option - E Hydraulic PalmTech Joystick, All-in-one control. Leading edge design.</p> <p>Option - Manual cowl mounted Levers, Easy-reach ergonomic design.</p> <p>Productivity Model E-Hydraulic Accutouch mini-lever - Standard, Fingertip activation, Best-in-class comfort. Excellent right-side access. Best-in-class comfort</p> <p>Option - E-Hydraulic PalmTech Joystick, All-in-one control, Leading edge design.</p>

# Veracitor VX Series

## Highlights and Options

Productivity highlights and options	Base	Value	Productivity
All LP Gas and Diesel Applications			
CSE (Continuous Stability Enhancement)	Std	Std	Std
Yale Global Hi-Vis™ mast	Std	Std	Std
Hall effect sensors and switches feature solid-state components - No adjustments	Std	Std	Std
Sealed electrical connectors keep out water and debris	Std	Std	Std
Directional change lever	Std	Std	Std
Oil immersed brakes	Opt	Opt	Std
<i>Techtronix 100 transmission</i>	Std		
One-Speed	✓		
Heavy-Duty Clutch Packs	✓		
Electronic Inching	✓		
Auto Deceleration System (ADS) – smooth auto braking	✓		
Controlled power reversal feature (CPR) – reduces tyre wear up to 50%	✓		
Controlled Roll-back on ramps (CRB) – enhances driver control	✓		
<i>Techtronix 100X transmission</i>		Std	
All the features of the Techtronix 100		✓	
Two-speed auto shift (2x forward / 1x reverse)		✓	
Extended Draw Bar Pull (EDBP)		✓	
<i>Techtronix 200X transmission</i>			Std
All the features of the Techtronix 100X			✓
Throttle Response Management (TRM)			✓
Auto Speed Hydraulics (ASH)			✓
Automatic Inching Control			✓
Accutouch Mini Lever electro-hydraulic controls	Opt	Std	Std
Palmtech Joystick, electro-hydraulic control handle	–	Opt	Opt
Return-to-set tilt	Opt	Opt	Opt
Rear drive handle with horn button	Std	Std	Std
Full suspension seat	Std	Std	Std
Full suspension swivel seat	Opt	Opt	Opt
Swing-out, drop-down EZ-Tank Bracket	Opt	Opt	Opt
Single inch/brake pedal	Std	Std	Std
Foot directional control	Opt	Opt	Opt
Front and rear work lights	Std	Std	Std
Mirrors – rear/side view	Opt	Opt	Opt
Quick disconnect with extension tubes	Opt	Opt	Opt
Productivity Package	Opt	Opt	Opt

# Veracitor VX Series

## Highlights and Options

Dependability highlights and options	Base	Value	Productivity
All LP Gas and Diesel Applications			
Rugged Powertrain	Std	Std	Std
Powertrain protection system	N/A	Opt	Opt
Intellix VSM (Vehicle Management System)	Std	Std	Std
Premium electronic monitoring	Opt	Opt	Opt
100% shock-mounted radiator	Std	Std	Std
Combi Cooler radiator	Std	Std	Std
CANbus electrical system	Std	Std	Std
Solid-state Hall Effect sensors - no adjustments required	Std	Std	Std
Sealed electrical connections	Std	Std	Std
Keyless start (with auxiliary key switch)	Opt	Opt	Opt
LED Brake and Backup Lights	Std	Std	Std
Precise wire harness routings	Std	Std	Std
Sealed dash display	Std	Std	Std
Drive lights and rear works lights with halogen bulbs	Std	Std	Std
Electronic horn	Std	Std	Std
O-ring face seal hydraulic fittings	Std	Std	Std
10-micron high performance in-tank hydraulic oil filter	Std	Std	Std
Electronically controlled transmissions	Std	Std	Std
Counterweight designed to maximise air flow - enhanced cooling	Std	Std	Std
High air intake with pre-cleaner	Opt	Opt	Opt
Accumulator	Opt	Opt	Opt
Traction Speed Limiter	N/A	Opt	Opt
FleetCare Package	N/A	Opt	Opt

Note: Std = Standard, Opt = Optional, N/A = Not Available

Lift Truck performance may be affected by the condition of the vehicle, how it is equipped and the application. Consult your Yale Industrial Truck Dealer for further information. Specifications are subject to change without notice.



# Veracitor VX Series

## Highlights and Options

Ergonomic highlights and options	Base	Value	Productivity
All LP Gas and Diesel Applications			
Infinite adjustment steer column	Std	Std	Std
Optimised step height 425mm	Std	Std	Std
Excellent mast visibility	Std	Std	Std
Excellent rearward visibility	Std	Std	Std
Dash display positioned for optimum visibility	Std	Std	Std
Low brake pedal effort	Std	Std	Std
Small 30cm steering wheel with spinner knob	Std	Std	Std
Single inching/brake pedal with excellent ergonomic positioning	Std	Std	Std
Conveniently located storage compartment	Std	Std	Std
Isolated powertrain	Std	Std	Std
Enhanced insulated non-metallic hood	Std	Std	Std
Auto Deceleration System (Techtronix 100 and 100X transmissions)	Std	Std	N/A
Dynamic Auto Deceleration System	N/A	N/A	Std
Conveniently located cowl-mounted hydraulics	Std	N/A	N/A
Accutouch Mini Lever electro-hydraulic controls with fully adjustable armrest	Opt	Std	Std
Palmtech Joystick, electro-hydraulic control handle	N/A	Opt	Opt
Low noise hydraulic pump	Std	Std	Std
Floormat	Std	Std	Std
Swing out LP tank bracket	Std	Std	Std
Swing-out, drop-down EZ-Tank Bracket	Opt	Opt	Opt
Return-to-set tilt	Opt	Opt	Opt
Rear drive handle with horn button	Std	Std	Std
Full suspension seat	Std	Std	Std
Full suspension swivel seat	Opt	Opt	Opt
Single inch/brake pedal	Std	Std	Std
Foot directional control pedal	Opt	Opt	Opt
Load Weight Indicator	Opt	Opt	Opt

# Veracitor VX Series

## Highlights and Options

Cost of Ownership highlights and options	Base	Value	Productivity
All LP Gas and Diesel Applications			
Heavy-duty "Combi-Cooler" radiator	Std	Std	Std
Electronically controlled transmissions	Std	Std	Std
Counterweight designed to maximise air flow	Std	Std	Std
Electronic systems monitoring	Std	Std	Std
Auto Deceleration System (Techtronix 100 and 100X transmissions)	Std	Std	N/A
Dynamic Auto Deceleration System	N/A	N/A	Std
Controlled power reversal	Std	Std	Std
Throttle response management	N/A	N/A	Std
Oil immersed brakes	Std	Std	Std
Powertrain protection system	N/A	Opt	Opt
Premium monitoring package	Opt	Opt	Opt
Impact monitor	Opt	Opt	Opt
Load Weight Display	Opt	Opt	Opt
High intake with pre-cleaner	Opt	Opt	Opt
Paper applications kit	Opt	Opt	Opt
Accumulator	Opt	Opt	Opt
Vented hood	Opt	Opt	Opt
Radiator lint screen	Opt	Opt	Opt
Traction speed limiter	N/A	Opt	Opt
Operator password	Opt	Opt	Opt
FleetCare package	Opt	Opt	Opt
Rental package	Opt	Opt	Opt
Attachment carriage	Std	Std	Std
Integral side shift carriage	Opt	Opt	Opt

# Veracitor VX Series

## Highlights and Options

Service highlights and options	Base	Value	Productivity
All LPG and Diesel Applications			
Cowl-to-counterweight access	Std	Std	Std
Easy floorplate removal – no tools required	Std	Std	Std
On-board diagnostics with advanced dash display	Std	Std	Std
PC-based diagnostics enabling fast and accurate troubleshooting	Std	Std	Std
Daily checks located on same side of truck and colour coded for quick identification	Std	Std	Std
Uncluttered layout with superb hydraulic and electrical routings	Std	Std	Std
Superior filtration system	Std	Std	Std
Intellix VSM (Vehicle Management System)	Std	Std	Std
CANbus electrical system	Std	Std	Std
Robust transmission clutch packs	Std	Std	Std
Sealed electrical connectors	Std	Std	Std
O-ring face seal on all high pressure hydraulic connections	Std	Std	Std
Hall effect sensors and other solid state components require no adjustment	Std	Std	Std
Oil immersed brakes	Std	Std	Std
Operator password	Opt	Opt	Opt
Halogen bulbs utilised on drive and work lights	Std	Std	Std
Premium monitoring system	Opt	Opt	Opt
Paper applications kit	Opt	Opt	Opt
Powertrain protection system	N/A	Opt	Opt
LED brake and reverse lights	Std	Std	Std
LED work lights	Opt	Opt	Opt
Vented hood	Opt	Opt	Opt
Swing-out, drop-down EZ-Tank Bracket	Opt	Opt	Opt



# Dimensions (Diesel)

## Truck Dimensions

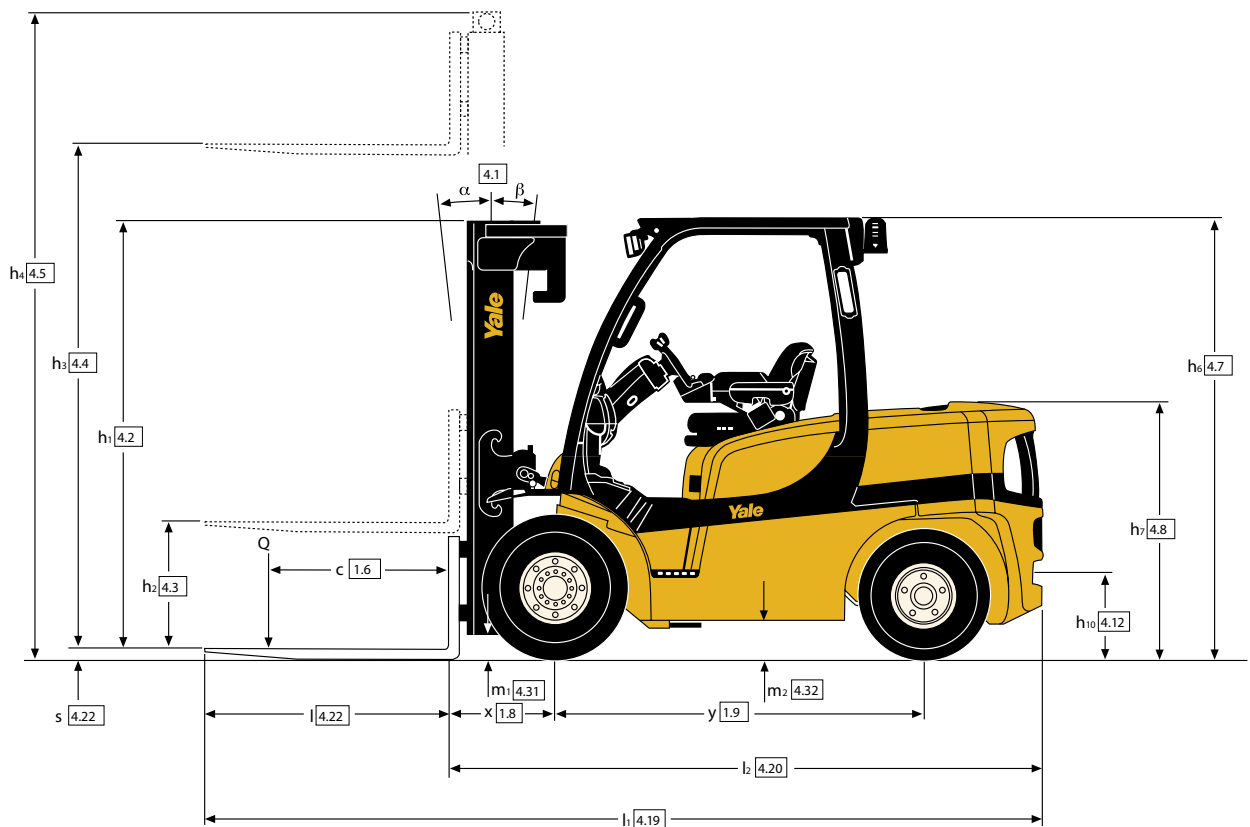
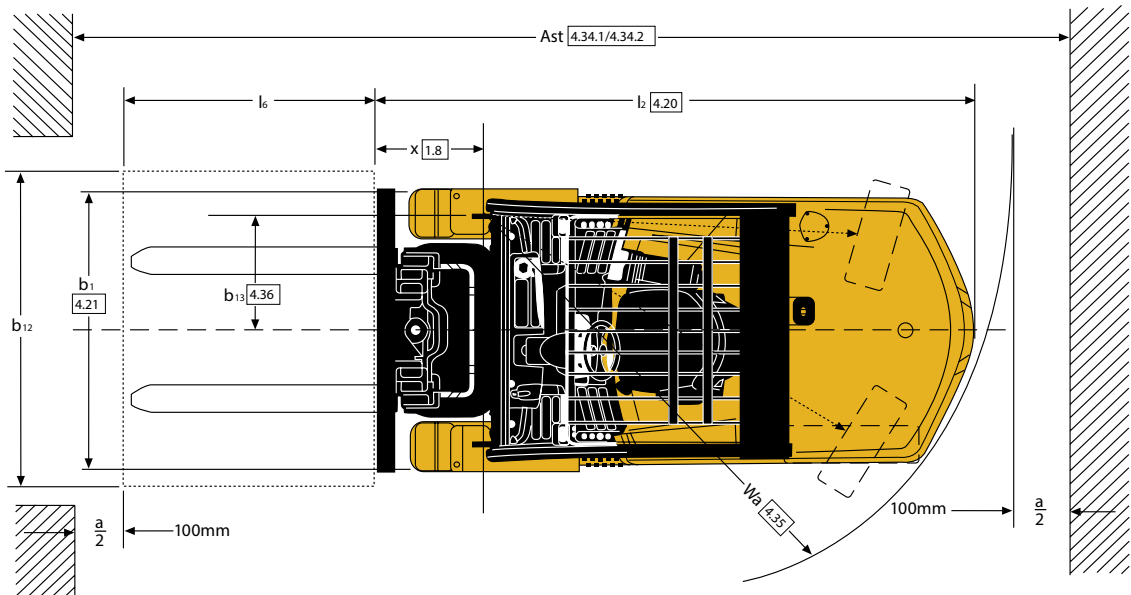

# Specifications (Diesel)

## Engine Specifications

Diesel Engine Specification	
Engine	Kubota V3600
Cylinders	Inline 4
Displacement	3.6 litre
Power	57kW @ 2,200rpm
Torque	296Nm @ 1,600rpm

## Options

- Powertrain protection system
- Premium monitoring package
- Hydraulic Accumulator, recommended for use with clamping attachments
- Keyless start (with Passcode access)
- Traction speed limiter
- Swing-out, drop-down EZ-Tank bracket
- Right hand armrest incorporating AccuTouch™ mini-lever electrohydraulic controls, direction switch and horn button
- Return-to-set tilt
- Swivel full suspension seat
- Foot directional control
- Operator password
- Mirrors - dual side view
- Alarm-reverse actuated 82-102dB(A) - self adjusting
- Amber strobe light - continuous activated
- Impact monitor
- Paper applications kits
- 4 function (2 aux) hydraulic control valve
- Load weight indicator
- Cabin and Air Conditioned Cabin
- Partial Cabins
- Lowered Overhead Guard and Cabin
- Yale Vision Telemetry System

## Capacities table - Standard carriage

Load centre	GDP40VX5	GDP40VX6	GDP45SVX5	GDP45VX6	GDP50VX	GDP55VX
mm	kg	kg	kg	kg	kg	kg
0	4000	4300	4500	5000	5400	5950
200	4000	4300	4500	5000	5400	5950
500	4000	4300	4500	5000	5400	5950
600	3670	4000	4000	4500	5000	5500
800	3310	3450	3610	4030	4460	4900
1000	2760	2760	3150	3520	3900	4280
1200	2300	2300	2800	3130	3460	3800
1400	1970	1970	2520	2810	3110	3420
1600	1720	1720	2290	2560	2830	3000

## Capacities graph - Standard carriage

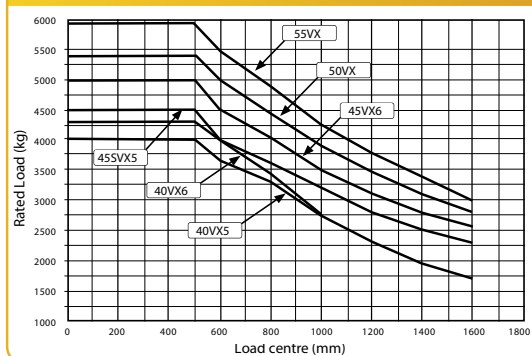

## Capacities table - ISS

Load centre	GDP40VX5	GDP40VX6	GDP45SVX5	GDP45VX6	GDP50VX	GDP55VX
mm	kg	kg	kg	kg	kg	kg
0	4000	4300	4500	5000	5400	5950
200	4000	4300	4500	5000	5400	5950
500	4000	4300	4440	4970	5400	5950
600	3670	4000	4000	4500	5000	5500
800	3320	3450	3500	3920	4340	4770
1000	2760	2760	3070	3430	3800	4180
1200	2300	2300	2730	3050	3380	3720
1400	1970	1970	2460	2750	3050	3350
1600	1720	1720	2240	2500	2770	3000

## Capacities graph - ISS

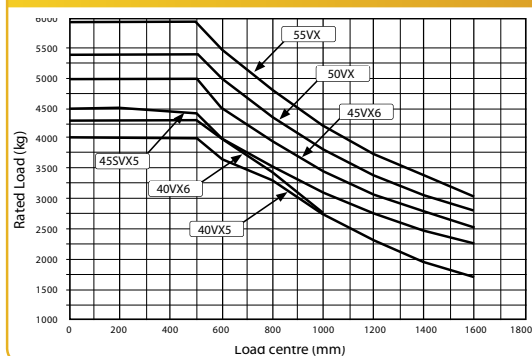

## Powertrains

Combustion engine	1.3	Drive: electric (battery or mains), diesel, petrol, fuel gas		Diesel
	7.1	Engine manufacturer/type		Kubota 3600 IDI-T
	7.2	Engine power according to ISO 1585	kW	57
	7.3	Rated speed	min-1	2400
	7.3.1	Torque at 1/min	Nm/min-1	296 / 1600
	7.4	Number of cylinders/displacement	cm3	4 / 3620
	7.10	Battery voltage/nominal capacity	✓ (V)/(Ah)	12 / 105
Drive mechanism	8.1	Type of drive unit		Hydrodynamic
	8.2	Manufacturer/type		NMHG/Electronic
	8.6	Wheel drive/drive axle manufacturer/type		Dana or NMHG/WBA
	8.11	Service brake		Hydraulic
	8.12	Parking brake		Multi Disc Brake

✓ Battery ampere hour (Ah) nominal capacity ratings are estimated.

# Mast & Capacity Details (Diesel)

## GDP 40VX5, GDP 40VX6 Mast details and capacity ratings (kg) - Superelastic tyres

Model		GDP 40 VX5											GDP 40 VX6				
Tyre size, front		250 x 15											250 x 15				
Overall width, front		1402mm											1402mm				
Mast	h <sub>1</sub> (mm)	h <sub>2+S</sub> (mm)	h <sub>3+S</sub> (mm)	h <sub>4</sub> (mm) <sup>(1)</sup>	h <sub>4</sub> (mm) <sup>(2)</sup>	Tilt		Forks			Integral Sideshift			Forks		Integral Sideshift	
						F	B	Load centre (kg)			Load centre (kg)			Load centre (kg)		Load centre (kg)	
								500	600	700	500	600	700	600	700	600	700
2 Stage LFL	2175	150	3050	3815	4300	6	10	4000	3670	3580	4000	3670	3470	4000	3890	4000	3770
	2475	150	3650	4415	4900	6	10	4000	3670	3570	4000	3670	3460	4000	3870	4000	3750
	2775	150	4250	5015	5500	6	10	4000	3670	3550	4000	3670	3440	4000	3860	4000	3740
	3225	150	4950	5715	6200	6	6	3880	3560	3430	3880	3560	3320	3890	3720	3890	3610
2 Stage FFL	2175	1355	3075	3890	4325	6	10	4000	3670	3450	4000	3670	3400	4000	3750	4000	3690
	2475	1655	3675	4490	4925	6	10	4000	3670	3440	4000	3650	3380	4000	3730	3990	3670
3 Stage FFL	2175	1355	4415	5225	5665	6	6	4000	3670	3430	3970	3630	3350	4000	3720	3950	3640
	2375	1555	4950	5765	6200	6	6	3880	3560	3310	3840	3510	3230	3880	3600	3820	3520
	2475	1655	5250	6065	6500	6	6	3800	3490	3240	3760	3440	3170	3810	3530	3740	3450
	2575	1755	5550	6365	6800	6	6	3730	3420	3170	3670	3360	3090	3740	3450	3660	3370
	2775	1955	6000	6815	7250	6	6	3600	3290	3050	3530	3230	2980	3620	3330	3530	3250

<sup>(1)</sup> Without load backrest. <sup>(2)</sup> With load backrest. Specification data based on standard carriage, load backrest, and 1000mm (GDP40VX5) / 1200mm (GDP 40VX6 - GDP 55VX) forks.

## GDP 45SVX5, GDP 45VX6 Mast details and capacity ratings (kg) - Superelastic tyres

Model		GDP 45 SVX5											GDP 45 VX6				
Tyre size, front		250 x 15											300 x 15				
Overall width, front		1402mm											1450mm				
Mast	h <sub>1</sub> (mm)	h <sub>2+S</sub> (mm)	h <sub>3+S</sub> (mm)	h <sub>4</sub> (mm) <sup>(1)</sup>	h <sub>4</sub> (mm) <sup>(2)</sup>	Tilt		Forks			Integral Sideshift			Forks		Integral Sideshift	
						F	B	Load centre (kg)			Load centre (kg)			Load centre (kg)		Load centre (kg)	
								500	600	700	500	600	700	600	700	600	700
2 Stage LFL	2215	160	2800	3730	4065	6	10	4500	4000	3890	4440	4000	3770	4500	4340	4500	4210
	2515	160	3400	4330	4665	6	10	4500	4000	3870	4420	4000	3750	4500	4330	4500	4200
	2815	160	4000	4930	5265	6	10	4500	4000	3860	4410	4000	3740	4500	4310	4500	4180
	3265	160	4700	5630	5965	6	6	4380	3900	3730	4260	3900	3620	4390	4180	4390	4060
	3665	160	5300	6230	6565	6	6	4230	3760	3580	4090	3750	3470	4250	4030	4230	3910
	4065	160	5900	6830	7165	6	6	4040	3620	3420	3900	3580	3310	4100	3860	4050	3740
2 Stage FFL	2215	1230	2825	3810	4090	6	10	4500	4000	3860	4410	4000	3740	4500	4310	4500	4180
	2515	1530	3425	4410	4690	6	10	4500	4000	3840	4390	4000	3720	4500	4290	4500	4170
3 Stage FFL	2215	1230	4145	5130	5415	6	6	4500	4000	3820	4370	4000	3700	4500	4270	4490	4150
	2515	1530	5000	5985	6265	6	6	4300	3820	3630	4150	3810	3520	4310	4080	4290	3960
	2615	1630	5300	6285	6565	6	6	4210	3750	3560	4070	3730	3450	4240	4000	4210	3890

<sup>(1)</sup> Without load backrest. <sup>(2)</sup> With load backrest. Specification data based on standard carriage, load backrest, and 1000mm (GDP40VX5) / 1200mm (GDP 40VX6 - GDP 55VX) forks.

## GDP 50VX, GDP 55VX Mast details and capacity ratings (kg) - Superelastic tyres

Model		GDP 50 VX											GDP 55 VX			
Tyre size, front		300 x 15											300 x 15			
Overall width, front		1450mm											1450mm			
Mast	h <sub>1</sub> (mm)	h <sub>2+S</sub> (mm)	h <sub>3+S</sub> (mm)	h <sub>4</sub> (mm) <sup>(1)</sup>	h <sub>4</sub> (mm) <sup>(2)</sup>	Tilt		Forks		Integral Sideshift		Forks		Integral Sideshift		
						F	B	600	700	600	700	600	700	600	700	
2 Stage LFL	2215	160	2800	3730	4065	6	10	5000	4810	5000	4670	5500	5280	5500	5130	
	2515	160	3400	4330	4665	6	10	5000	4790	5000	4650	5500	5260	5500	5120	
	2815	160	4000	4930	5265	6	10	5000	4780	5000	4640	5500	5250	5500	5100	
	3265	160	4700	5630	5965	6	6	4890	4640	4880	4510	5380	5110	5370	4970	
	3665	160	5300	6230	6565	6	6	4740	4480	4700	4350	5230	4940	5190	4800	
	4065	160	5900	6830	7165	6	6	4570	4300	4520	4170	5050	4750	5000	4620	
2 Stage FFL	2215	1230	2825	3810	4090	6	10	5000	4770	5000	4640	5500	5250	5500	5100	
	2515	1530	3425	4410	4690	6	10	5000	4760	5000	4620	5500	5230	5500	5080	
3 Stage FFL	2215	1230	4145	5130	5415	6	6	5000	4740	4990	4610	5500	5210	5490	5070	
	2515	1530	5000	5985	6265	6	6	4800	4530	4770	4410	5290	5000	5260	4860	
	2615	1630	5300	6285	6565	6	6	4730	4450	4690	4330	5210	4920	5170	4780	

<sup>(1)</sup> Without load backrest. <sup>(2)</sup> With load backrest. Specification data based on standard carriage, load backrest, and 1000mm (GDP40VX5) / 1200mm (GDP 40VX6 - GDP 55VX) forks.



# Mast & Capacity Details (Diesel)

## GDP 40VX5, GDP 40VX6 Mast details and capacity ratings (kg) - Pneumatic radial tyres

Model		GDP 40 VX5											GDP 40 VX6				
Tyre size, front		250 x R15											250 x R15				
Overall width, front		1402mm											1402mm				
Mast	h <sub>1</sub> (mm)	h <sub>2+s</sub> (mm)	h <sub>3+s</sub> (mm)	h <sub>4</sub> (mm) <sup>(1)</sup>	h <sub>4</sub> (mm) <sup>(2)</sup>	Tilt		Forks			Integral Sideshift			Forks		Integral Sideshift	
								Load centre (kg)			Load centre (kg)			Load centre (kg)		Load centre (kg)	
						F	B	500	600	700	500	600	700	600	700	600	700
2 Stage LFL	2175	150	3050	3815	4300	6	10	4000	3670	3580	4000	3670	3470	4000	3890	4000	3770
	2475	150	3650	4415	4900	6	10	4000	3670	3570	4000	3670	3460	4000	3870	4000	3750
	2775	150	4250	5015	5500	6	10	4000	3670	3550	4000	3670	3440	4000	3860	4000	3740
	3225	150	4950	5715	6200	6	6	3880	3560	3420	3880	3560	3320	3890	3720	3890	3610
2 Stage FFL	2175	1355	3075	3890	4325	6	10	4000	3670	3450	4000	3670	3400	4000	3750	4000	3690
	2475	1655	3675	4490	4925	6	10	4000	3670	3440	4000	3670	3380	4000	3730	3990	3670
3 Stage FFL	2175	1355	4415	5225	5665	6	6	4000	3670	3430	3970	3630	3350	4000	3720	3950	3640
	2375	1555	4950	5765	6200	6	6	3870*	3550*	3310*	3830*	3510*	3230*	3880*	3600*	3820*	3520*
	2475	1655	5250	6065	6500	6	6	3800*	3490*	3230*	3750*	3430*	3160*	3810*	3520*	3740*	3440*
	2575	1755	5550	6365	6800	6	6	3730**	3420**	3170**	3670**	3360**	3090**	3740**	3450**	3660**	3370**
	2775	1955	6000	6815	7250	6	6	3600**	3310**	3050**	3530**	3230**	2980**	3620**	3330**	3530**	3250**

<sup>(1)</sup> Without load backrest. <sup>(2)</sup> With load backrest. \* Wide Tread or Dual Drive Wheels Required. \*\* Dual Drive Wheels Required. Specification data based on standard carriage, load backrest, and 1000mm (GDP40VX5) / 1200mm (GDP 40VX6 - GDP 55VX) forks.

## GDP 45SVX5, GDP 45VX6 Mast details and capacity ratings (kg) - Pneumatic radial tyres

Model		GDP 45 SVX5											GDP 45 VX6				
Tyre size, front		250/70 x R15											315/70 x R15				
Overall width, front		1402mm											1450mm				
Mast	h <sub>1</sub> (mm)	h <sub>2+s</sub> (mm)	h <sub>3+s</sub> (mm)	h <sub>4</sub> (mm) <sup>(1)</sup>	h <sub>4</sub> (mm) <sup>(2)</sup>	Tilt		Forks			Integral Sideshift			Forks		Integral Sideshift	
								Load centre (kg)			Load centre (kg)			Load centre (kg)		Load centre (kg)	
						F	B	500	600	700	500	600	700	600	700	600	700
2 Stage LFL	2215	160	2800	3730	4065	6	10	4500	4000	3890	4440	4000	3770	4500	4340	4500	4210
	2515	160	3400	4330	4665	6	10	4500	4000	3870	4420	4000	3750	4500	4330	4500	4200
	2815	160	4000	4930	5265	6	10	4500	4000	3860	4410	4000	3740	4500	4310	4500	4180
	3265	160	4700	5630	5965	6	6	4380	3890	3730	4260	3890	3610	4390	4180	4390	4060
	3665	160	5300	6230	6565	6	6	4230*	3760*	3570*	4080*	3750*	3460*	4240*	4020*	4220*	3900*
	4065	160	5900	6830	7165	6	6	4040**	3610**	3410**	3900**	3580**	3310**	4080*	3840*	4030*	3730*
2 Stage FFL	2215	1230	2825	3810	4090	6	10	4500	4000	3860	4410	4000	3740	4500	4310	4500	4180
	2515	1530	3425	4410	4690	6	10	4500	4000	3840	4390	4000	3720	4500	4290	4500	4170
3 Stage FFL	2215	1230	4145	5130	5415	6	6	4500	4000	3820	4370	4000	3700	4500	4270	4490	4150
	2515	1530	5000	5985	6265	6	6	4250*	3820*	3630*	4150**	3810**	3520**	4310*	4070*	4280*	3950*
	2615	1630	5300	6285	6565	6	6	4210**	3750**	3560**	4070**	3730**	3450**	4230*	3990*	4200*	3880*

<sup>(1)</sup> Without load backrest. <sup>(2)</sup> With load backrest. \* Wide Tread or Dual Drive Wheels Required. \*\* Dual Drive Wheels Required. Specification data based on standard carriage, load backrest, and 1000mm (GDP40VX5) / 1200mm (GDP 40VX6 - GDP 55VX) forks.

## GDP 50VX, GDP 55VX Mast details and capacity ratings (kg) - Pneumatic radial tyres

Model		GDP 50 VX											GDP 55 VX			
Tyre size, front		315/70 x R15											315/70-R15			
Overall width, front		1450mm											1450mm			
Mast	h <sub>1</sub> (mm)	h <sub>2+s</sub> (mm)	h <sub>3+s</sub> (mm)	h <sub>4</sub> (mm) <sup>(1)</sup>	h <sub>4</sub> (mm) <sup>(2)</sup>	Tilt		Forks		Integral Sideshift		Forks		Integral Sideshift		
								Load centre (kg)		Load centre (kg)		Load centre (kg)		Load centre (kg)		
						F	B	600	700	600	700	600	700	600	700	
2 Stage LFL	2215	160	2800	3730	4065	6	10	5000	4810	5000	4670	5500	5280	5500	5130	
	2515	160	3400	4330	4665	6	10	5000	4790	5000	4650	5500	5260	5500	5120	
	2815	160	4000	4930	5265	6	10	5000	4780	5000	4640	5500	5250	5500	5100	
	3265	160	4700	5630	5965	6	6	4880	4640	4870	4500	5380*	5110*	5370*	4960*	
	3665	160	5300	6230	6565	6	6	4730*	4470*	4700*	4340*	5220*	4930*	5180*	4790*	
	4065	160	5900	6830	7165	6	6	4570**	4300**	4510**	4170**	5050**	4750**	4990**	4610**	
2 Stage FFL	2215	1230	2825	3810	4090	6	10	5000	4770	5000	4640	5500	5250	5500	5100	
	2515	1530	3425	4410	4690	6	10	5000	4760	5000	4620	5500	5230	5500	5080	
3 Stage FFL	2215	1230	4145	5130	5415	6	6	5000	4740	4990	4610	5500	5210	5490	5070	
	2515	1530	5000	5985	6265	6	6	4800*	4530*	4760*	4400*	5290*	4990*	5260*	4860*	
	2615	1630	5300	6285	6565	6	6	4730**	4450**	4680**	4330**	5210**	4910**	5170**	4780**	

<sup>(1)</sup> Without load backrest. <sup>(2)</sup> With load backrest. \* Wide Tread or Dual Drive Wheels Required. \*\* Dual Drive Wheels Required. Specification data based on standard carriage, load backrest, and 1000mm (GDP40VX5) / 1200mm (GDP 40VX6 - GDP 55VX) forks.

# Specifications (Diesel)

## VDI 2198 – General Specifications, Diesel powered GDP 40VX5, GDP 40VX6, GDP 45SVX5

			Yale	Yale	Yale	Yale	
Distinguishing mark	1.1	Manufacturer (abbreviation)					
	1.2	Manufacturer's type designation			GDP 40VX5		
		Engine/Transmission		Kubota 3.6L Standard Electronic, 1-Speed	Kubota 3.6L Standard Electronic, 2-Speed	Kubota 3.6L Techtronix 100, 1-Speed	Kubota 3.6L Techtronix 200, 2-Speed
		Model		Base	Base	Value	Value
		Brake Type		Premium Oil-immersed	Premium Oil-immersed	Premium Oil-immersed	Premium Oil-immersed
	1.3	Drive: electric (battery or mains), diesel, petrol, fuel gas		Diesel	Diesel	Diesel	Diesel
	1.4	Operator type: hand, pedestrian, standing, seated, orderpicker		Seated	Seated	Seated	Seated
	1.5	Rated capacity / rated load	Q (t)	4.0	4.0	4.0	4.0
	1.6	Load centre distance	c (mm)	500	500	500	500
	1.8	Load distance, centre of drive axle to fork	x (mm)	523	523	523	523
1.8.1	Load distance, centre of drive axle to fork (ISS Carriage)	x (mm)	555	555	555	555	
1.9	Wheelbase	y (mm)	1830	1830	1830	1830	
Weights	2.1	Service weight	kg	6264	6264	6264	6264
	2.2	Axle loading, laden front / rear	kg	8969 / 1295	8969 / 1295	8969 / 1295	8969 / 1295
	2.3	Axle loading, unladen front / rear	kg	2733 / 3531	2733 / 3531	2733 / 3531	2733 / 3531
Tyres/chassis	3.1	Tyres: P = pneumatic, V = cushion, SE = superelastic		SE	SE	SE	SE
	3.2	Tyre size, front		250 x 15	250 x 15	250 x 15	250 x 15
	3.3	Tyre size, rear		700 x 12	700 x 12	700 x 12	700 x 12
	3.5	Number of wheels, front/rear (x = driven wheels)		2x / 2	2x / 2	2x / 2	2x / 2
	3.6	Tread, front	b <sub>10</sub> (mm)	1152	1152	1152	1152
	3.7	Tread, rear	b <sub>11</sub> (mm)	1136	1136	1136	1136
	Dimensions	4.1	Tilt of mast/fork carriage, forward / backward	α / β (°)	6 / 10	6 / 10	6 / 10
4.2		Height, mast lowered	h <sub>1</sub> (mm)	2171	2171	2171	2171
4.3		Free lift ▲	h <sub>2</sub> (mm)	100	100	100	100
4.4		Lift ▲	h <sub>3</sub> (mm)	3000	3000	3000	3000
4.5		Height, mast extended +	h <sub>4</sub> (mm)	3815	3815	3815	3815
4.7		Height of overhead guard (cabin)	h <sub>6</sub> (mm)	2258	2258	2258	2258
4.8		Seat height relating to SIP/stand height ✕	h <sub>7</sub> (mm)	1279	1279	1279	1279
4.12		Coupling height	h <sub>10</sub> (mm)	429	429	429	429
4.19		Overall length	l <sub>1</sub> (mm)	3946	3946	3946	3946
4.20		Length to face of forks (Standard Carriage)	l <sub>2</sub> (mm)	2946	2946	2946	2946
4.20.1		Length to face of forks (Integrated Side Shift Carriage)	l <sub>2</sub> (mm)	2978	2978	2978	2978
4.21		Overall width □	b <sub>1</sub> (mm)	1402 / 1485 / 1773	1402 / 1485 / 1773	1402 / 1485 / 1773	1402 / 1485 / 1773
4.22		Fork dimensions ISO 2331	s/e/l (mm)	50 / 120 / 1000	50 / 120 / 1000	50 / 120 / 1000	50 / 120 / 1000
4.23		Fork carriage ISO 2328, class/type A, B		IIIA	IIIA	IIIA	IIIA
4.24		Fork carriage width (Standard Carriage) +	b <sub>3</sub> (mm)	1219	1219	1219	1219
4.24.1		Fork carriage width (ISS Carriage) +	b <sub>3</sub> (mm)	1219	1219	1219	1219
4.31		Ground clearance, laden, below mast	m <sub>1</sub> (mm)	151	151	151	151
4.32		Ground clearance, centre of wheelbase	m <sub>2</sub> (mm)	194	194	194	194
4.33		Load dimension b <sub>12</sub> x l <sub>6</sub> crossways	b <sub>12</sub> x l <sub>6</sub> (mm)	1200 x 1000	1200 x 1000	1200 x 1000	1200 x 1000
4.34		Aisle width predetermined load dimensions ○	A <sub>st</sub> (mm)	4293	4293	4293	4293
4.34.1	Aisle width with pallets 1000mm x 1200mm crossways ○	A <sub>st</sub> (mm)	3970	3970	3970	3970	
4.34.2	Aisle width with pallets 800mm wide x 1200mm lengthways ○	A <sub>st</sub> (mm)	3970	3970	3970	3970	
4.35	Turning radius	W <sub>3</sub> (mm)	2570	2570	2570	2570	
4.36	Internal turning radius	b <sub>13</sub> (mm)	751	751	751	751	
4.41	90° intersecting aisle (with pallet W = 1200mm, L = 1000mm)	(mm)	2298	2298	2298	2298	
4.42	Step height (from ground to running board)	(mm)	801	801	801	801	
4.43	Step height (between intermediate steps between running board and floor)	(mm)	441	441	441	441	
Performance data	5.1	Travel speed laden/unladen	km/h	179 / 18.8	20.5 / 22.9	179 / 18.8	20.5 / 22.9
	5.1.1	Travel speed, laden/unladen, backwards	km/h	179 / 18.8	179 / 18.8	179 / 18.8	179 / 18.8
	5.2	Lift speed, laden/unladen	m/s	0.53 / 0.60	0.53 / 0.60	0.53 / 0.60	0.53 / 0.60
	5.3	Lowering speed, laden/unladen	m/s	0.55 / 0.47	0.55 / 0.47	0.55 / 0.47	0.55 / 0.47
	5.5	Drawbar pull, laden/unladen *	N	25973 / 15616	31095 / 15616	25973 / 15616	31095 / 15616
	5.7	Gradeability, laden/unladen **	N	27.3 / 27.2	33.2 / 27.2	27.3 / 27.2	33.2 / 27.2
	5.9	Acceleration time, laden/unladen ***	%	5.8 / 4.8	5.9 / 5	5.8 / 4.8	5.9 / 5
	5.10	Service brake	s	Hydraulic	Hydraulic	Hydraulic	Hydraulic
	7.5	Fuel consumption according to VDI cycle	l/h or kg/h	5.7	5.9	5.7	5.9
	Addition data	8.1	Type of drive unit		Hydrodynamic	Hydrodynamic	Hydrodynamic
10.1		Operating pressure for attachments	bar	155	155	155	155
10.2		Oil volume for attachments ◇	l/min	83.3	83.3	83.3	83.3
10.3		Hydraulic oil tank, capacity	litres	51.0	51.0	51.0	51.0
10.4		Fuel tank, capacity	litres	79.0	79.0	79.0	79.0
10.7		Sound pressure level at the driver's seat ⇨ ★	dB(A)	81	81	81	81
10.7.1		Sound power level during the workcycle ◆	dB(A)	101	101	101	101
10.7.2		Guaranteed sound power 2000/14/EC	dB(A)	105	105	105	105
10.8		Towing coupling, type DIN		Pin	Pin	Pin	Pin

▲ Top of forks.  
 ▴ Add 32mm with load backrest.  
 ✕ Full suspension seat in depressed position.  
 + W/o load backrest, add 32mm with load backrest.  
 □ Standard/Wide/Dual.

○ Stacking aisle width (lines 4.34 & 4.34.2) are based on the VDI standard calculation as shown on illustration. The British Industrial Truck Association recommends the addition of 100mm to the total clearance (dimension a) for extra

operating margin at the rear of the truck.  
 \* at 1.6km/h.  
 \*\* at 4.8km/h. Gradeability figures are provided for comparison of tractive performance, but are not intended to endorse the operation of

the vehicle on the stated inclines. Follow instructions in the operating manual regarding operation on inclines.  
 \*\*\* to 15m (per VDI 2198 December 2012).

# Specifications (Diesel)

Yale	Yale	Yale	Yale	Yale	Yale	Yale	Yale	1.1
GDP 40VX6				GDP 45SVX5				1.2
Kubota 3.6L Standard Electronic, 1-Speed	Kubota 3.6L Standard Electronic, 2-Speed	Kubota 3.6L Techtronix 100, 1-Speed	Kubota 3.6L Techtronix 200, 2-Speed	Kubota 3.6L Standard Electronic, 1-Speed	Kubota 3.6L Standard Electronic, 2-Speed	Kubota 3.6L Techtronix 100, 1-Speed	Kubota 3.6L Techtronix 200, 2-Speed	
Base	Base	Value	Value	Base	Base	Value	Value	
Premium Oil-immersed	Premium Oil-immersed	Premium Oil-immersed	Premium Oil-immersed	Premium Oil-immersed	Premium Oil-immersed	Premium Oil-immersed	Premium Oil-immersed	
Diesel	Diesel	Diesel	Diesel	Diesel	Diesel	Diesel	Diesel	1.3
Seated	Seated	Seated	Seated	Seated	Seated	Seated	Seated	1.4
4.0	4.0	4.0	4.0	4.5	4.5	4.5	4.5	1.5
600	600	600	600	500	500	500	500	1.6
523	523	523	523	591	591	591	591	1.8
555	555	555	555	608	608	608	608	1.8.1
1830	1830	1830	1830	1830	1830	1830	1830	1.9
6470	6470	6470	6470	6826	6826	6826	6826	2.1
9133 / 1337	9133 / 1337	9133 / 1337	9133 / 1337	10114 / 1212	10114 / 1212	10114 / 1212	10114 / 1212	2.2
2678 / 3792	2678 / 3792	2678 / 3792	2678 / 3792	2931 / 3895	2931 / 3895	2931 / 3895	2931 / 3895	2.3
SE	SE	SE	SE	SE	SE	SE	SE	3.1
250 x 15	250 x 15	250 x 15	250 x 15	250 x 15	250 x 15	250 x 15	250 x 15	3.2
700 x 12	700 x 12	700 x 12	700 x 12	700 x 12	700 x 12	700 x 12	700 x 12	3.3
2x / 2	2x / 2	2x / 2	2x / 2	2x / 2	2x / 2	2x / 2	2x / 2	3.5
1152	1152	1152	1152	1152	1152	1152	1152	3.6
1136	1136	1136	1136	1136	1136	1136	1136	3.7
6 / 10	6 / 10	6 / 10	6 / 10	6 / 10	6 / 10	6 / 10	6 / 10	4.1
2171	2171	2171	2171	2215	2215	2215	2215	4.2
100	100	100	100	100	100	100	100	4.3
3000	3000	3000	3000	2740	2740	2740	2740	4.4
3815	3815	3815	3815	3730	3730	3730	3730	4.5
2258	2258	2258	2258	2258	2258	2258	2258	4.7
1279	1279	1279	1279	1279	1279	1279	1279	4.8
429	429	429	429	429	429	429	429	4.12
3977	3977	3977	3977	4266	4266	4266	4266	4.19
2977	2977	2977	2977	3066	3066	3066	3066	4.20
3009	3009	3009	3009	3083	3083	3083	3083	4.20.1
1402 / 1485 / 1773	1402 / 1485 / 1773	1402 / 1485 / 1773	1402 / 1485 / 1773	1402 / 1485 / 1773	1402 / 1485 / 1773	1402 / 1485 / 1773	1402 / 1485 / 1773	4.21
50 / 120 / 1000	50 / 120 / 1000	50 / 120 / 1000	50 / 120 / 1000	50 / 120 / 1000	50 / 120 / 1000	50 / 120 / 1000	50 / 120 / 1000	4.22
IIIA	IIIA	IIIA	IIIA	IVA	IVA	IVA	IVA	4.23
1219	1219	1219	1219	1219	1219	1219	1219	4.24
1219	1219	1219	1219	1219	1219	1219	1219	4.24.1
151	151	151	151	151	151	151	151	4.31
194	194	194	194	194	194	194	194	4.32
1200 x 1000	1200 x 1000	1200 x 1000	1200 x 1000	1200 x 1000	1200 x 1000	1200 x 1000	1200 x 1000	4.33
3799	3799	3799	3799	3819	3819	3819	3819	4.34
3999	3999	3999	3999	4019	4019	4019	4019	4.34.1
3999	3999	3999	3999	4019	4019	4019	4019	4.34.2
2599	2599	2599	2599	2619	2619	2619	2619	4.35
751	751	751	751	751	751	751	751	4.36
2314	2314	2314	2314	2332	2332	2332	2332	4.41
801	801	801	801	801	801	801	801	4.42
441	441	441	441	441	441	441	441	4.43
179 / 18.8	20.3 / 22.8	179 / 18.8	20.3 / 22.8	176 / 18.7	19.8 / 22.7	176 / 18.7	19.8 / 22.7	5.1
179 / 18.8	179 / 18.8	179 / 18.8	179 / 18.8	176 / 18.7	176 / 18.7	176 / 18.7	176 / 18.7	5.1.1
0.53 / 0.60	0.53 / 0.60	0.53 / 0.60	0.53 / 0.60	0.45 / 0.49	0.45 / 0.49	0.45 / 0.49	0.45 / 0.49	5.2
0.55 / 0.47	0.55 / 0.47	0.55 / 0.47	0.55 / 0.47	0.51 / 0.42	0.51 / 0.42	0.51 / 0.42	0.51 / 0.42	5.3
25933 / 15292	31055 / 15292	25933 / 15292	31055 / 15292	25765 / 16781	30887 / 16781	25765 / 16781	30887 / 16781	5.5
26.6 / 25.7	32.4 / 25.7	26.6 / 25.7	32.4 / 25.7	24.6 / 26.7	29.9 / 26.7	24.6 / 26.7	29.9 / 26.7	5.7
5.9 / 4.9	5.9 / 5	5.9 / 4.9	5.9 / 5	6.1 / 5	6.1 / 5.1	6.1 / 5	6.1 / 5.1	5.9
Hydraulic	Hydraulic	Hydraulic	Hydraulic	Hydraulic	Hydraulic	Hydraulic	Hydraulic	5.10
5.7	6.0	5.7	6.0	6.1	6.4	6.1	6.4	75
Hydrodynamic	Hydrodynamic	Hydrodynamic	Hydrodynamic	Hydrodynamic	Hydrodynamic	Hydrodynamic	Hydrodynamic	8.1
155	155	155	155	155	155	155	155	10.1
83.3	83.3	83.3	83.3	83.3	83.3	83.3	83.3	10.2
51.0	51.0	51.0	51.0	51.0	51.0	51.0	51.0	10.3
79.0	79.0	79.0	79.0	79.0	79.0	79.0	79.0	10.4
81	81	81	81	81	81	81	81	10.7
101	101	101	101	101	101	101	101	10.7.1
105	105	105	105	105	105	105	105	10.7.2
Pin	Pin	Pin	Pin	Pin	Pin	Pin	Pin	10.8

Distinguishing mark

Weights

Tyres/chassis

Dimensions

Performance data

Addition data

◊ Variable.  
 ⇒ With and without cab.  
 ★ Lpaz. Measured according to the test cycles and based on the weighting values contained in EN12053.  
 ◆ LWAZ, measured according to the test cycles and based on the weighting values contained in EN12053.  
 Base models truck specification data based on: 3050mm (GDP40VX5-GDP40VX6) / 2800mm (GDP45VX5 - GDP55VX) TOF 2 stage LFL mast with standard carriage, 1000mm (GDP40VX5) / 1200mm (GDP40VX6 - GDP55VX) forks with manual hydraulics.  
 Value models truck specification data based on: 3050mm (GDP40VX5-GDP40VX6) / 2800mm (GDP45VX5 - GDP55VX) TOF 2 stage LFL mast with standard carriage, 1000mm (GDP40VX5) / 1200mm (GDP40VX6 - GDP55VX) forks with manual hydraulics.



# Specifications (Diesel)

## VDI 2198 – General Specifications, Diesel powered GDP 40VX5, GDP 40VX6, GDP 45SVX5

			Yale	Yale	Yale	Yale	
Distinguishing mark	1.1	Manufacturer (abbreviation)					
	1.2	Manufacturer's type designation			GDP 45VX6		
		Engine/Transmission		Kubota 3.6L Standard Electronic, 1-Speed	Kubota 3.6L Standard Electronic, 2-Speed	Kubota 3.6L Techtronix 100, 1-Speed	Kubota 3.6L Techtronix 200, 2-Speed
		Model		Base	Base	Value	Value
		Brake Type		Premium Oil-immersed	Premium Oil-immersed	Premium Oil-immersed	Premium Oil-immersed
	1.3	Drive: electric (battery or mains), diesel, petrol, fuel gas		Diesel	Diesel	Diesel	Diesel
	1.4	Operator type: hand, pedestrian, standing, seated, orderpicker		Seated	Seated	Seated	Seated
	1.5	Rated capacity / rated load	Q (t)	4.5	4.5	4.5	4.5
	1.6	Load centre distance	c (mm)	600	600	600	600
1.8	Load distance, centre of drive axle to fork	x (mm)	591	591	591	591	
1.8.1	Load distance, centre of drive axle to fork (ISS Carriage)	x (mm)	608	608	608	608	
1.9	Wheelbase	y (mm)	2100	2100	2100	2100	
Weights	2.1	Service weight	kg	7225	7225	7225	7225
	2.2	Axle loading, laden front / rear	kg	10323 / 1402	10323 / 1402	10323 / 1402	10323 / 1402
	2.3	Axle loading, unladen front / rear	kg	3271 / 3954	3271 / 3954	3271 / 3954	3271 / 3954
Tyres/chassis	3.1	Tyres: P = pneumatic, V = cushion, SE = superelastic		SE	SE	SE	SE
	3.2	Tyre size, front		300 x 15	300 x 15	300x15	300 x 15
	3.3	Tyre size, rear		28 x 9-15	28 x 9-15	28 x 9-15	28 x 9-15
	3.5	Number of wheels, front/rear (x = driven wheels)		2x / 2	2x / 2	2x / 2	2x / 2
	3.6	Tread, front	b <sub>10</sub> (mm)	1150	1150	1150	1150
	3.7	Tread, rear	b <sub>11</sub> (mm)	1162	1162	1162	1162
	Dimensions	4.1	Tilt of mast/fork carriage, forward / backward	α / β (°)	6 / 10	6 / 10	6 / 10
4.2		Height, mast lowered	h <sub>1</sub> (mm)	2215	2215	2215	2215
4.3		Free lift ▲	h <sub>2</sub> (mm)	100	100	100	100
4.4		Lift ▲	h <sub>3</sub> (mm)	2740	2740	2740	2740
4.5		Height, mast extended +	h <sub>4</sub> (mm)	3730	3730	3730	3730
4.7		Height of overhead guard (cabin)	h <sub>6</sub> (mm)	2300	2300	2300	2300
4.8		Seat height relating to SIP/stand height ✕	h <sub>7</sub> (mm)	1321	1321	1321	1321
4.12		Coupling height	h <sub>10</sub> (mm)	429	429	429	429
4.19		Overall length	l <sub>1</sub> (mm)	4457	4457	4457	4457
4.20		Length to face of forks (Standard Carriage)	l <sub>2</sub> (mm)	3257	3257	3257	3257
4.20.1		Length to face of forks (Integrated Side Shift Carriage)	l <sub>2</sub> (mm)	3274	3274	3274	3274
4.21		Overall width ▢	b <sub>1</sub> (mm)	1450 / 1575 / 1875	1450 / 1575 / 1875	1450 / 1575 / 1875	1450 / 1575 / 1875
4.22		Fork dimensions ISO 2331	s/e/l (mm)	60 / 150 / 1200	60 / 150 / 1200	60 / 150 / 1200	60 / 150 / 1200
4.23		Fork carriage ISO 2328, class/type A, B		IVA	IVA	IVA	IVA
4.24		Fork carriage width (Standard Carriage) +	b <sub>3</sub> (mm)	1219	1219	1219	1219
4.24.1		Fork carriage width (ISS Carriage) +	b <sub>3</sub> (mm)	1372	1372	1372	1372
4.31		Ground clearance, laden, below mast	m <sub>1</sub> (mm)	194	194	194	194
4.32		Ground clearance, centre of wheelbase	m <sub>2</sub> (mm)	237	237	237	237
4.33		Load dimension b <sub>12</sub> x l <sub>6</sub> crossways	b <sub>12</sub> x l <sub>6</sub> (mm)	1200 x 1000	1200 x 1000	1200 x 1000	1200 x 1000
4.34		Aisle width predetermined load dimensions ○	A <sub>st</sub> (mm)	4037	4037	4037	4037
4.34.1	Aisle width with pallets 1000mm x 1200mm crossways ○	A <sub>st</sub> (mm)	4237	4237	4237	4237	
4.34.2	Aisle width with pallets 800mm wide x 1200mm lengthways ○	A <sub>st</sub> (mm)	4237	4237	4237	4237	
4.35	Turning radius	W <sub>a</sub> (mm)	2837	2837	2837	2837	
4.36	Internal turning radius	b <sub>13</sub> (mm)	800	800	800	800	
4.41	90° intersecting aisle (with pallet W = 1200mm, L = 1000mm)	(mm)	2447	2447	2447	2447	
4.42	Step height (from ground to running board)	(mm)	844	844	844	844	
4.43	Step height (between intermediate steps between running board and floor)	(mm)	484	484	484	484	
Performance data	5.1	Travel speed laden/unladen	km/h	16.6 / 17.6	18.7 / 21.2	16.6 / 17.6	18.7 / 21.2
	5.1.1	Travel speed, laden/unladen, backwards	km/h	16.6 / 17.6	16.6 / 17.6	16.6 / 17.6	16.6 / 17.6
	5.2	Lift speed, laden/unladen	m/s	0.45 / 0.49	0.45 / 0.49	0.45 / 0.49	0.45 / 0.49
	5.3	Lowering speed, laden/unladen	m/s	0.51 / 0.42	0.51 / 0.42	0.51 / 0.42	0.51 / 0.42
	5.5	Drawbar pull, laden/unladen *	N	27834 / 18782	33291/18782	27834 / 18782	33291 / 18782
	5.7	Gradeability, laden/unladen **	N	24.3 / 28.3	29.4 / 28.3	24.3 / 28.3	29.4 / 28.3
	5.9	Acceleration time, laden/unladen ***	%	6.3 / 5.2	6.3 / 5.3	6.3 / 5.2	6.3 / 5.3
	5.10	Service brake	s	Hydraulic	Hydraulic	Hydraulic	Hydraulic
	7.5	Fuel consumption according to VDI cycle	l/h or kg/h	6.4	6.8	6.4	6.8
	Addition data	8.1	Type of drive unit		Hydrodynamic	Hydrodynamic	Hydrodynamic
10.1		Operating pressure for attachments	bar	155	155	155	155
10.2		Oil volume for attachments ◇	l/min	83.3	83.3	83.3	83.3
10.3		Hydraulic oil tank, capacity	litres	678	678	678	678
10.4		Fuel tank, capacity	litres	100.3	100.3	100.3	100.3
10.7		Sound pressure level at the driver's seat ↔ ★	dB(A)	81	81	81	81
10.7.1		Sound power level during the workcycle ◆	dB(A)	101	101	101	101
10.7.2		Guaranteed sound power 2000/14/EC	dB(A)	105	105	105	105
10.8		Towing coupling, type DIN		Pin	Pin	Pin	Pin

▲ Top of forks. ○ Stacking aisle width (lines 4.34 & 4.34.1 & 4.34.2) are based on the V.D.I. standard calculation as shown on illustration. The British Industrial Truck Association recommends the addition of 100mm to the total clearance (dimension a) for extra operating margin at the rear of the truck. \* at 1.6km/h. \*\* at 4.8km/h. Gradeability figures are provided for comparison of tractive performance, but are not intended to endorse the operation of the vehicle on the stated inclines. Follow instructions in the operating manual regarding operation on inclines. \*\*\* to 15m (per VDI 2198 December 2012).

# Specifications (Diesel)

Yale	Yale	Yale	Yale	Yale	Yale	Yale	Yale	1.1
GDP 50VX6				GDP 55VX6				1.2
Kubota 3.6L Standard Electronic, 1-Speed	Kubota 3.6L Standard Electronic, 2-Speed	Kubota 3.6L Techtronix 100, 1-Speed	Kubota 3.6L Techtronix 200, 2-Speed	Kubota 3.6L Standard Electronic, 1-Speed	Kubota 3.6L Standard Electronic, 2-Speed	Kubota 3.6L Techtronix 100, 1-Speed	Kubota 3.6L Techtronix 200, 2-Speed	
Base	Base	Value	Value	Base	Base	Value	Value	
Premium Oil-immersed	Premium Oil-immersed	Premium Oil-immersed	Premium Oil-immersed	Premium Oil-immersed	Premium Oil-immersed	Premium Oil-immersed	Premium Oil-immersed	
Diesel	Diesel	Diesel	Diesel	Diesel	Diesel	Diesel	Diesel	1.3
Seated	Seated	Seated	Seated	Seated	Seated	Seated	Seated	1.4
5.0	5.0	5.0	5.0	5.5	5.5	5.5	45.5	1.5
600	600	600	600	600	600	600	600	1.6
591	591	591	591	591	591	591	591	1.8
608	608	608	608	608	608	608	608	1.8.1
2100	2100	2100	2100	2100	2100	2100	2100	1.9
7520	7520	7520	7520	7811	7811	7811	7811	2.1
11041 / 1478	11041 / 1478	11041 / 1478	11041 / 1478	11754 / 1558	11754 / 1558	11754 / 1558	11754 / 1558	2.2
3206 / 4314	3206 / 4314	3206 / 4314	3206 / 4314	3134 / 4677	3134 / 4677	3134 / 4677	3134 / 4677	2.3
SE	SE	SE	SE	SE	SE	SE	SE	3.1
300 x 15	300 x 15	300 x 15	300 x 15	300 x 15	300 x 15	300 x 15	300 x 15	3.2
28 x 9-15	28 x 9-15	28 x 9-15	28 x 9-15	28 x 9-15	28 x 9-15	28 x 9-15	28 x 9-15	3.3
2x / 2	2x / 2	2x / 2	2x / 2	2x / 2	2x / 2	2x / 2	2x / 2	3.5
1150	1150	1150	1150	1150	1150	1150	1150	3.6
1162	1162	1162	1162	1162	1162	1162	1162	3.7
6 / 10	6 / 10	6 / 10	6 / 10	6 / 10	6 / 10	6 / 10	6 / 10	4.1
2215	2215	2215	2215	2215	2215	2215	2215	4.2
100	100	100	100	100	100	100	100	4.3
2740	2740	2740	2740	2740	2740	2740	2740	4.4
3730	3730	3730	3730	3730	3730	3730	3730	4.5
2300	2300	2300	2300	2300	2300	2300	2300	4.7
1321	1321	1321	1321	1321	1321	1321	1321	4.8
429	429	429	429	429	429	429	429	4.12
4500	4500	4500	4500	4541	4541	4541	4541	4.19
3300	3300	3300	3300	3341	3341	3341	3341	4.20
3317	3317	3317	3317	3358	3358	3358	3358	4.20.1
1450 / 1575 / 1875	1450 / 1575 / 1875	1450 / 1575 / 1875	1450 / 1575 / 1875	1450 / 1575 / 1875	1450 / 1575 / 1875	1450 / 1575 / 1875	1450 / 1575 / 1875	4.21
60 / 150 / 1200	60 / 150 / 1200	60 / 150 / 1200	60 / 150 / 1200	60 / 150 / 1200	60 / 150 / 1200	60 / 150 / 1200	60 / 150 / 1200	4.22
IVA	IVA	IVA	IVA	IVA	IVA	IVA	IVA	4.23
1219	1219	1219	1219	1219	1219	1219	1219	4.24
1372	1372	1372	1372	1372	1372	1372	1372	4.24.1
194	194	194	194	194	194	194	194	4.31
237	237	237	237	237	237	237	237	4.32
1200 x 1000	1200 x 1000	1200 x 1000	1200 x 1000	1200 x 1000	1200 x 1000	1200 x 1000	1200 x 1000	4.33
4077	4077	4077	4077	4115	4115	4115	4115	4.34
4277	4277	4277	4277	4315	4315	4315	4315	4.34.1
4277	4277	4277	4277	4315	4315	4315	4315	4.34.2
2877	2877	2877	2877	2915	2915	2915	2915	4.35
800	800	800	800	800	800	800	800	4.36
2469	2469	2469	2469	2490	2490	2490	2490	4.41
844	844	844	844	844	844	844	844	4.42
484	484	484	484	484	484	484	484	4.43
16.5 / 176	18.5 / 21.3	16.5 / 176	18.5 / 21.3	16.2 / 175	18.1 / 21.2	16.2 / 175	18.1 / 21.2	5.1
16.5 / 176	16.5 / 176	16.5 / 176	16.5 / 176	16.2 / 175	16.2 / 175	16.2 / 175	16.2 / 175	5.1.1
0.45 / 0.49	0.45 / 0.49	0.45 / 0.49	0.45 / 0.49	0.45 / 0.49	0.45 / 0.49	0.45 / 0.49	0.45 / 0.49	5.2
0.51 / 0.42	0.51 / 0.42	0.51 / 0.42	0.51 / 0.42	0.51 / 0.42	0.51 / 0.42	0.51 / 0.42	0.51 / 0.42	5.3
27776 / 18399	33233 / 18399	27776 / 18399	33233 / 18399	27620 / 17976	33078 / 17976	27620 / 17976	33078 / 17976	5.5
23.6 / 26.5	28.6 / 26.5	23.6 / 26.5	28.6 / 26.5	22 / 24.8	26.6 / 24.8	22 / 24.8	26.6 / 24.8	5.7
6.3 / 5.2	6.3 / 5.3	6.3 / 5.2	6.3 / 5.3	6.5 / 5.2	6.5 / 5.3	6.5 / 5.2	6.5 / 5.3	5.9
Hydraulic	Hydraulic	Hydraulic	Hydraulic	Hydraulic	Hydraulic	Hydraulic	Hydraulic	5.10
6.8	7.2	6.8	7.2	7.2	7.7	7.2	7.7	7.5
Hydrodynamic	Hydrodynamic	Hydrodynamic	Hydrodynamic	Hydrodynamic	Hydrodynamic	Hydrodynamic	Hydrodynamic	8.1
155	155	155	155	155	155	155	155	10.1
83.3	83.3	83.3	83.3	83.3	83.3	83.3	83.3	10.2
678	678	678	678	678	678	678	678	10.3
100.3	100.3	100.3	100.3	100.3	100.3	100.3	100.3	10.4
81	81	81	81	81	81	81	81	10.7
101	101	101	101	101	101	101	101	10.7.1
105	105	105	105	105	105	105	105	10.7.2
Pin	Pin	Pin	Pin	Pin	Pin	Pin	Pin	10.8

Distinguishing mark

Weights

Tyres/chassis

Dimensions

Performance data

Addition data

◇ Variable.  
 ◊ With and without cab.  
 ★ Lpaz. Measured according to the test cycles and based on the weighting values contained in EN12053.  
 ◆ LWAZ, measured according to the test cycles and based on the weighting values contained in EN12053.  
 Base models truck specification data based on: 3050mm (GDP40VX5-GDP40VX6) / 2800mm (GDP455VX5 - GDP55VX) TOF 2 stage LFL mast with standard carriage, 1000mm (GDP40VX5) / 1200mm (GDP40VX6 - GDP55VX) forks with manual hydraulics.  
 Value models truck specification data based on: 3050mm (GDP40VX5-GDP40VX6) / 2800mm (GDP455VX5 - GDP55VX) TOF 2 stage LFL mast with standard carriage, 1000mm (GDP40VX5) / 1200mm (GDP40VX6 - GDP55VX) forks with manual hydraulics.

# Dimensions (LPG)

## Truck Dimensions

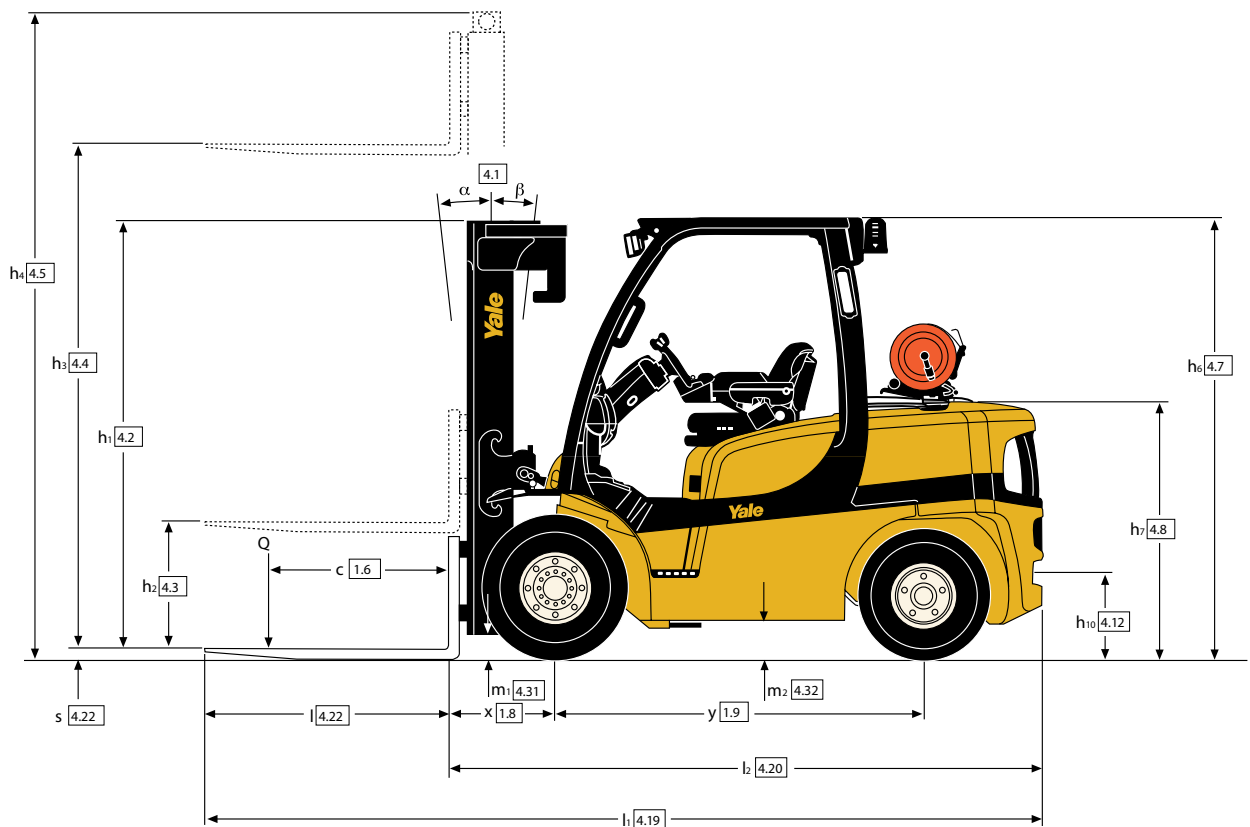
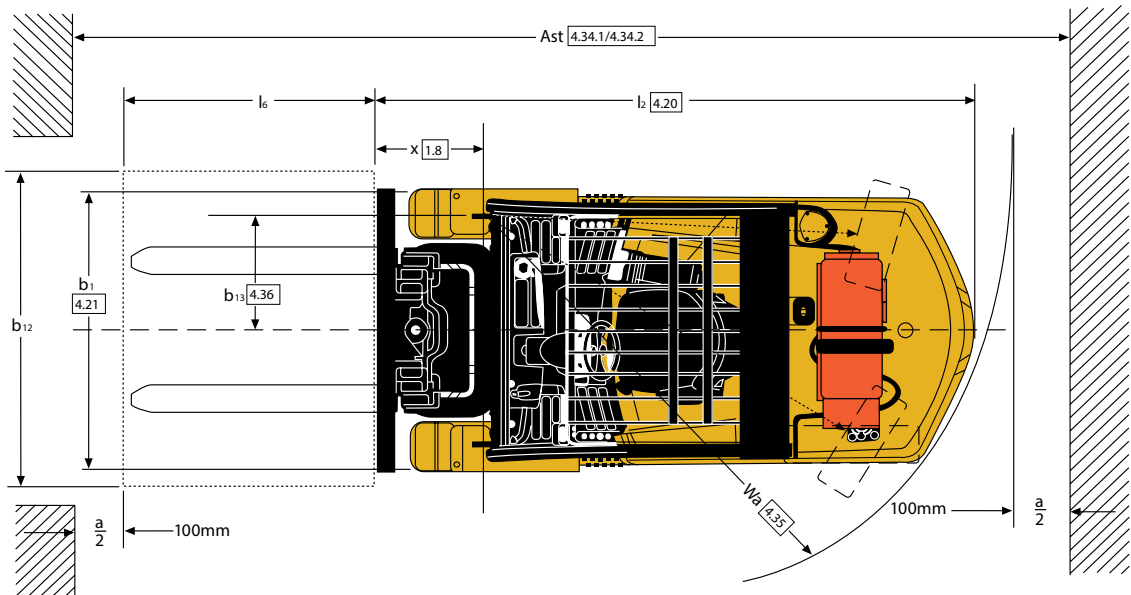

# Specifications (LPG)

## Engine Specifications

LPG Engine Specification	
Engine	Kubota WG3800
Cylinders	In line 4
Displacement	3769cc
Power SWB	54.9kW @ 1,800rpm
Power LWB	64.0kW @ 2,200rpm
Torque	300Nm @ 1,000rpm

## Options

- Powertrain protection system
- Premium monitoring package
- Hydraulic Accumulator, recommended for use with clamping attachments
- Keyless start (with Passcode access)
- Traction speed limiter
- Swing-out, drop-down EZ-Tank bracket
- Right hand armrest incorporating AccuTouch™ mini-lever electrohydraulic controls, direction switch and horn button
- Return-to-set tilt
- Swivel full suspension seat
- Foot directional control
- Operator password
- Mirrors - dual side view
- Alarm-reverse actuated 82-102dB(A) - self adjusting
- Amber strobe light - continuous activated
- Impact monitor
- Paper applications kits
- 4 function (2 aux) hydraulic control valve
- Load weight indicator
- Cabin and Air Conditioned Cabin
- Partial Cabins
- Lowered Overhead Guard and Cabin
- YaleVision Telemetry System

## Capacities table - Standard carriage

Load centre	GLP40VX5	GLP40VX6	GLP45SVX5	GLP45VX6	GLP50VX	GLP55VX
mm	kg	kg	kg	kg	kg	kg
0	4000	4300	4500	5000	5400	5950
200	4000	4300	4500	5000	5400	5950
500	4000	4300	4500	5000	5400	5950
600	3670	4000	4000	4500	5000	5500
800	3310	3450	3610	4030	4460	4900
1000	2760	2760	3150	3520	3900	4280
1200	2300	2300	2800	3130	3460	3800
1400	1970	1970	2520	2810	3110	3420
1600	1720	1720	2290	2560	2830	3000

## Capacities graph - Standard carriage

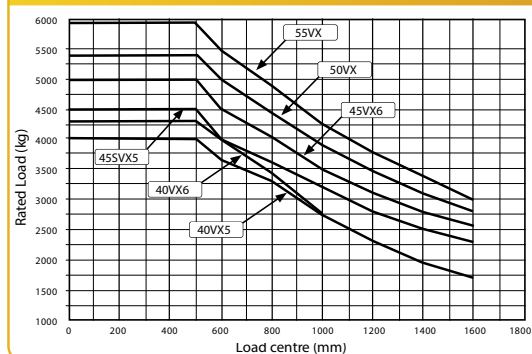

## Capacities table - ISS

Load centre	GLP40VX5	GLP40VX6	GLP45SVX5	GLP45VX6	GLP50VX	GLP55VX
mm	kg	kg	kg	kg	kg	kg
0	4000	4300	4500	5000	5400	5950
200	4000	4300	4500	5000	5400	5950
500	4000	4300	4440	4970	5400	5950
600	3670	4000	4000	4500	5000	5500
800	3320	3450	3500	3920	4340	4770
1000	2760	2760	3070	3430	3800	4180
1200	2300	2300	2730	3050	3380	3720
1400	1970	1970	2460	2750	3050	3350
1600	1720	1720	2240	2500	2770	3000

## Capacities graph - ISS

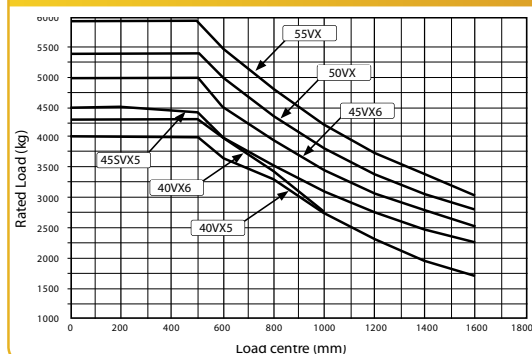

## Powertrains

		LPG SWB	LPG LWB	
Combustion engine	1.3 Drive: electric (battery or mains), diesel, petrol, fuel gas			
	7.1 Engine manufacturer/type	Kubota WG3800	Kubota WG3800	
	7.2 Engine power according to ISO 1585	kW	54.9	64.0
	7.3 Rated speed	min-1	1800	2200
	7.3.1 Torque at 1/min	Nm/min-1	300 / 1200	300 / 1200
	7.4 Number of cylinders/displacement	cm3	4 / 3769	4 / 3769
	7.10 Battery voltage/nominal capacity ✓	(V)/(Ah)	12 / 105	12 / 105
Drive mechanism	8.1 Type of drive unit	Hydrodynamic	Hydrodynamic	
	8.2 Manufacturer/type	NMHG/Electronic	NMHG/Electronic	
	8.6 Wheel drive/drive axle manufacturer/type	Dana/WBA	Dana/WBA	
	8.11 Service brake	Multi Disc Brake	Multi Disc Brake	
	8.12 Parking brake	Multi Disc Brake	Multi Disc Brake	

✓ Battery ampere hour (Ah) nominal capacity ratings are estimated.



# Mast & Capacity Details (LPG)

## GLP 40VX5, GLP 40VX6 Mast details and capacity ratings (kg) - Superelastic tyres

Model		GLP 40 VX5											GLP 40 VX6				
Tyre size, front		250 x 15											250 x 15				
Overall width, front		1402mm											1402mm				
Mast	h <sub>1</sub> (mm)	h <sub>2+s</sub> (mm) <sup>(1)</sup>	h <sub>3+s</sub> (mm)	h <sub>4</sub> (mm) <sup>(1)</sup>	h <sub>4</sub> (mm) <sup>(2)</sup>	Tilt		Forks			Integral Sideshift			Forks		Integral Sideshift	
						F	B	Load centre (kg)			Load centre (kg)			Load centre (kg)		Load centre (kg)	
								500	600	700	500	600	700	600	700	600	700
2 Stage LFL	2175	150	3050	3815	4300	6	10	4000	3670	3580	4000	3670	3470	4000	3890	4000	3770
	2475	150	3650	4415	4900	6	10	4000	3670	3570	4000	3670	3460	4000	3870	4000	3750
	2775	150	4250	5015	5500	6	10	4000	3670	3550	4000	3670	3440	4000	3860	4000	3740
	3225	150	4950	5715	6200	6	6	3880	3560	3430	3880	3560	3320	3890	3720	3890	3610
2 Stage FFL	2175	1355	3075	3890	4325	6	10	4000	3670	3450	4000	3670	3400	4000	3750	4000	3690
	2475	1655	3675	4490	4925	6	10	4000	3670	3440	4000	3650	3380	4000	3730	3990	3670
3 Stage FFL	2175	1355	4415	5225	5665	6	6	4000	3670	3430	3970	3630	3350	4000	3720	3950	3640
	2375	1555	4950	5765	6200	6	6	3880	3560	3310	3840	3510	3230	3880	3600	3820	3520
	2475	1655	5250	6065	6500	6	6	3800	3490	3240	3760	3440	3170	3810	3530	3740	3450
	2575	1755	5550	6365	6800	6	6	3730	3420	3170	3670	3360	3090	3740	3450	3660	3370
	2775	1955	6000	6815	7250	6	6	3600	3290	3050	3530	3230	2980	3620	3330	3530	3250

<sup>(1)</sup> Without load backrest. <sup>(2)</sup> With load backrest. Specification data based on standard carriage, load backrest, and 1000mm (GLP40VX5) / 1200mm (GLP 40VX6 - GLP 55VX) forks.

## GLP 45SVX5, GLP 45VX6 Mast details and capacity ratings (kg) - Superelastic tyres

Model		GLP 45 SVX5											GLP 45 VX6				
Tyre size, front		250 x 15											300 x 15				
Overall width, front		1402mm											1450mm				
Mast	h <sub>1</sub> (mm)	h <sub>2+s</sub> (mm) <sup>(1)</sup>	h <sub>3+s</sub> (mm)	h <sub>4</sub> (mm) <sup>(1)</sup>	h <sub>4</sub> (mm) <sup>(2)</sup>	Tilt		Forks			Integral Sideshift			Forks		Integral Sideshift	
						F	B	Load centre (kg)			Load centre (kg)			Load centre (kg)		Load centre (kg)	
								500	600	700	500	600	700	600	700	600	700
2 Stage LFL	2215	160	2800	3730	4065	6	10	4500	4000	3890	4440	4000	3770	4500	4340	4500	4210
	2515	160	3400	4330	4665	6	10	4500	4000	3870	4420	4000	3750	4500	4330	4500	4200
	2815	160	4000	4930	5265	6	10	4500	4000	3860	4410	4000	3740	4500	4310	4500	4180
	3265	160	4700	5630	5965	6	6	4380	3900	3730	4260	3900	3620	4390	4180	4390	4060
	3665	160	5300	6230	6565	6	6	4230	3760	3580	4090	3750	3470	4250	4030	4230	3910
	4065	160	5900	6830	7165	6	6	4040	3620	3420	3900	3580	3310	4100	3860	4050	3740
2 Stage FFL	2215	1230	2825	3810	4090	6	10	4500	4000	3860	4410	4000	3740	4500	4310	4500	4180
	2515	1530	3425	4410	4690	6	10	4500	4000	3840	4390	4000	3720	4500	4290	4500	4170
3 Stage FFL	2215	1230	4145	5130	5415	6	6	4500	4000	3820	4370	4000	3700	4500	4270	4490	4150
	2515	1530	5000	5985	6265	6	6	4300	3820	3630	4150	3810	3520	4310	4080	4290	3960
	2615	1630	5300	6285	6565	6	6	4210	3750	3560	4070	3730	3450	4240	4000	4210	3890

<sup>(1)</sup> Without load backrest. <sup>(2)</sup> With load backrest. Specification data based on standard carriage, load backrest, and 1000mm (GLP40VX5) / 1200mm (GLP 40VX6 - GLP 55VX) forks.

## GLP 50VX, GLP 55VX Mast details and capacity ratings (kg) - Superelastic tyres

Model		GLP 50 VX											GLP 55 VX			
Tyre size, front		300 x 15											300 x 15			
Overall width, front		1450mm											1450mm			
Mast	h <sub>1</sub> (mm)	h <sub>2+s</sub> (mm) <sup>(1)</sup>	h <sub>3+s</sub> (mm)	h <sub>4</sub> (mm) <sup>(1)</sup>	h <sub>4</sub> (mm) <sup>(2)</sup>	Tilt		Forks		Integral Sideshift		Forks		Integral Sideshift		
						F	B	600	700	600	700	600	700	600	700	
2 Stage LFL	2215	160	2800	3730	4065	6	10	5000	4810	5000	4670	5500	5280	5500	5130	
	2515	160	3400	4330	4665	6	10	5000	4790	5000	4650	5500	5260	5500	5120	
	2815	160	4000	4930	5265	6	10	5000	4780	5000	4640	5500	5250	5500	5100	
	3265	160	4700	5630	5965	6	6	4890	4640	4880	4510	5380	5110	5370	4970	
	3665	160	5300	6230	6565	6	6	4740	4480	4700	4350	5230	4940	5190	4800	
	4065	160	5900	6830	7165	6	6	4570	4300	4520	4170	5050	4750	5000	4620	
2 Stage FFL	2215	1230	2825	3810	4090	6	10	5000	4770	5000	4640	5500	5250	5500	5100	
	2515	1530	3425	4410	4690	6	10	5000	4760	5000	4620	5500	5230	5500	5080	
3 Stage FFL	2215	1230	4145	5130	5415	6	6	5000	4740	4990	4610	5500	5210	5490	5070	
	2515	1530	5000	5985	6265	6	6	4800	4530	4770	4410	5290	5000	5260	4860	
	2615	1630	5300	6285	6565	6	6	4730	4450	4690	4330	5210	4920	5170	4780	

<sup>(1)</sup> Without load backrest. <sup>(2)</sup> With load backrest. Specification data based on standard carriage, load backrest, and 1000mm (GLP40VX5) / 1200mm (GLP 40VX6 - GLP 55VX) forks.

# Mast & Capacity Details (LPG)

## GLP 40VX5, GLP 40VX6 Mast details and capacity ratings (kg) - Pneumatic radial tyres

Model		GLP 40 VX5											GLP 40 VX6				
Tyre size, front		250 x R15											250 x R15				
Overall width, front		1402mm											1402mm				
Mast	h <sub>1</sub> (mm)	h <sub>2</sub> +s (mm) <sup>(1)</sup>	h <sub>3</sub> +s (mm)	h <sub>4</sub> (mm) <sup>(1)</sup>	h <sub>4</sub> (mm) <sup>(2)</sup>	Tilt		Forks			Integral Sideshift			Forks		Integral Sideshift	
						F	B	Load centre (kg)			Load centre (kg)			Load centre (kg)		Load centre (kg)	
								500	600	700	500	600	700	600	700	600	700
2 Stage LFL	2175	150	3050	3815	4300	6	10	4000	3670	3580	4000	3670	3470	4000	3890	4000	3770
	2475	150	3650	4415	4900	6	10	4000	3670	3570	4000	3670	3460	4000	3870	4000	3750
	2775	150	4250	5015	5500	6	10	4000	3670	3550	4000	3670	3440	4000	3860	4000	3740
	3225	150	4950	5715	6200	6	6	3880	3560	3420	3880	3560	3320	3890	3720	3890	3610
2 Stage FFL	2175	1355	3075	3890	4325	6	10	4000	3670	3450	4000	3670	3400	4000	3750	4000	3690
	2475	1655	3675	4490	4925	6	10	4000	3670	3440	4000	3670	3380	4000	3730	3990	3670
3 Stage FFL	2175	1355	4415	5225	5665	6	6	4000	3670	3430	3970	3630	3350	4000	3720	3950	3640
	2375	1555	4950	5765	6200	6	6	3870*	3550*	3310*	3830*	3510*	3230*	3880*	3600*	3820*	3520*
	2475	1655	5250	6065	6500	6	6	3800*	3490*	3230*	3750*	3430*	3160*	3810*	3520*	3740*	3440*
	2575	1755	5550	6365	6800	6	6	3730**	3420**	3170**	3670**	3360**	3090**	3740**	3450**	3660**	3370**
	2775	1955	6000	6815	7250	6	6	3600**	3310**	3050**	3530**	3230**	2980**	3620**	3330**	3530**	3250**

<sup>(1)</sup> Without load backrest. <sup>(2)</sup> With load backrest. \*Wide Tread or Dual Drive Wheels Required. \*\*Dual Drive Wheels Required. Specification data based on standard carriage, load backrest, and 1000mm (GLP40VX5) / 1200mm (GLP 40VX6 - GLP 55VX) forks.

## GLP 45SVX5, GLP 45VX6 Mast details and capacity ratings (kg) - Pneumatic radial tyres

Model		GLP 45 SVX5											GLP 45 VX6				
Tyre size, front		250/70 x R15											315/70 x R15				
Overall width, front		1402mm											1450mm				
Mast	h <sub>1</sub> (mm)	h <sub>2</sub> +s (mm) <sup>(1)</sup>	h <sub>3</sub> +s (mm)	h <sub>4</sub> (mm) <sup>(1)</sup>	h <sub>4</sub> (mm) <sup>(2)</sup>	Tilt		Forks			Integral Sideshift			Forks		Integral Sideshift	
						F	B	Load centre (kg)			Load centre (kg)			Load centre (kg)		Load centre (kg)	
								500	600	700	500	600	700	600	700	600	700
2 Stage LFL	2215	160	2800	3730	4065	6	10	4500	4000	3890	4440	4000	3770	4500	4340	4500	4210
	2515	160	3400	4330	4665	6	10	4500	4000	3870	4420	4000	3750	4500	4330	4500	4200
	2815	160	4000	4930	5265	6	10	4500	4000	3860	4410	4000	3740	4500	4310	4500	4180
	3265	160	4700	5630	5965	6	6	4380	3890	3730	4260	3890	3610	4390	4180	4390	4060
	3665	160	5300	6230	6565	6	6	4230*	3760*	3570*	4080*	3750*	3460*	4240*	4020*	4220*	3900*
	4065	160	5900	6830	7165	6	6	4040**	3610**	3410**	3900**	3580**	3310**	4080*	3840*	4030*	3730*
2 Stage FFL	2215	1230	2825	3810	4090	6	10	4500	4000	3860	4410	4000	3740	4500	4310	4500	4180
	2515	1530	3425	4410	4690	6	10	4500	4000	3840	4390	4000	3720	4500	4290	4500	4170
3 Stage FFL	2215	1230	4145	5130	5415	6	6	4500	4000	3820	4370	4000	3700	4500	4270	4490	4150
	2515	1530	5000	5985	6265	6	6	4250*	3820*	3630*	4150**	3810**	3520**	4310*	4070*	4280*	3950*
	2615	1630	5300	6285	6565	6	6	4210**	3750**	3560**	4070**	3730**	3450**	4230*	3990*	4200*	3880*

<sup>(1)</sup> Without load backrest. <sup>(2)</sup> With load backrest. \*Wide Tread or Dual Drive Wheels Required. \*\*Dual Drive Wheels Required. Specification data based on standard carriage, load backrest, and 1000mm (GLP40VX5) / 1200mm (GLP 40VX6 - GLP 55VX) forks.

## GLP 50VX, GLP 55VX Mast details and capacity ratings (kg) - Pneumatic radial tyres

Model		GLP 50 VX											GLP 55 VX			
Tyre size, front		315/70 x R15											315/70-R15			
Overall width, front		1450mm											1450mm			
Mast	h <sub>1</sub> (mm)	h <sub>2</sub> +s (mm) <sup>(1)</sup>	h <sub>3</sub> +s (mm)	h <sub>4</sub> (mm) <sup>(1)</sup>	h <sub>4</sub> (mm) <sup>(2)</sup>	Tilt		Forks		Integral Sideshift		Forks		Integral Sideshift		
						F	B	Load centre (kg)		Load centre (kg)		Load centre (kg)		Load centre (kg)		
								600	700	600	700	600	700	600	700	
2 Stage LFL	2215	160	2800	3730	4065	6	10	5000	4810	5000	4670	5500	5280	5500	5130	
	2515	160	3400	4330	4665	6	10	5000	4790	5000	4650	5500	5260	5500	5120	
	2815	160	4000	4930	5265	6	10	5000	4780	5000	4640	5500	5250	5500	5100	
	3265	160	4700	5630	5965	6	6	4880	4640	4870	4500	5380*	5110*	5370*	4960*	
	3665	160	5300	6230	6565	6	6	4730*	4470*	4700*	4340*	5220*	4930*	5180*	4790*	
	4065	160	5900	6830	7165	6	6	4570**	4300**	4510**	4170**	5050**	4750**	4990**	4610**	
2 Stage FFL	2215	1230	2825	3810	4090	6	10	5000	4770	5000	4640	5500	5250	5500	5100	
	2515	1530	3425	4410	4690	6	10	5000	4760	5000	4620	5500	5230	5500	5080	
3 Stage FFL	2215	1230	4145	5130	5415	6	6	5000	4740	4990	4610	5500	5210	5490	5070	
	2515	1530	5000	5985	6265	6	6	4800*	4530*	4760*	4400*	5290*	4990*	5260*	4860*	
	2615	1630	5300	6285	6565	6	6	4730**	4450**	4680**	4330**	5210**	4910**	5170**	4780**	

<sup>(1)</sup> Without load backrest. <sup>(2)</sup> With load backrest. \*Wide Tread or Dual Drive Wheels Required. \*\*Dual Drive Wheels Required. Specification data based on standard carriage, load backrest, and 1000mm (GLP40VX5) / 1200mm (GLP 40VX6 - GLP 55VX) forks.

# Specifications (LPG)

## VDI 2198 – General Specifications, LPG powered GLP 40VX5, GLP 40VX6, GLP 45SVX5

		Yale	Yale	Yale	
Distinguishing mark	1.1	Manufacturer (abbreviation)	Yale	Yale	
	1.2	Manufacturer's type designation		GLP 40VX5	
		Engine/Transmission	Kubota 3.8L Techtronix 100, 1-Speed	Kubota 3.8L Techtronix 200, 2-Speed	Kubota 3.8L Techtronix 200, 2-Speed
		Model	Value	Value	Productivity
		Brake Type	Standard or Premium Oil-immersed	Standard or Premium Oil-immersed	Premium Oil-immersed
	1.3	Drive: electric (battery or mains), diesel, petrol, fuel gas	LPG	LPG	LPG
	1.4	Operator type: hand, pedestrian, standing, seated, orderpicker	Seated	Seated	Seated
	1.5	Rated capacity / rated load	Q (t)	4.0	4.0
	1.6	Load centre distance	c (mm)	500	500
Weights	1.8	Load distance, centre of drive axle to fork	x (mm)	523	523
	1.8.1	Load distance, centre of drive axle to fork (ISS Carriage)	x (mm)	555	555
	1.9	Wheelbase	y (mm)	1830	1830
	2.1	Service weight	kg	6264	6264
	2.2	Axle loading, laden front / rear	kg	8969 / 1295	8969 / 1295
	2.3	Axle loading, unladen front / rear	kg	2733 / 3531	2733 / 3531
	3.1	Tyres: P = pneumatic, V = cushion, SE = superelastic		SE	SE
	3.2	Tyre size, front		250 x 15	250 x 15
	3.3	Tyre size, rear		700 x 12	700 x 12
Tyres/chassis	3.5	Number of wheels, front/rear (x = driven wheels)		2x / 2	2x / 2
	3.6	Tread, front	b <sub>10</sub> (mm)	1152	1152
	3.7	Tread, rear	b <sub>11</sub> (mm)	1136	1136
	4.1	Tilt of mast/fork carriage, forward / backward	α / β (°)	6 / 10	6 / 10
	4.2	Height, mast lowered	h <sub>1</sub> (mm)	2171	2171
	4.3	Free lift ▲	h <sub>2</sub> (mm)	100	100
	4.4	Lift ▲	h <sub>3</sub> (mm)	3000	3000
	4.5	Height, mast extended +	h <sub>4</sub> (mm)	3815	3815
	4.7	Height of overhead guard (cabin)	h <sub>6</sub> (mm)	2258	2258
Dimensions	4.8	Seat height relating to SIP/stand height ✕	h <sub>7</sub> (mm)	1279	1279
	4.12	Coupling height	h <sub>10</sub> (mm)	429	429
	4.19	Overall length	l <sub>1</sub> (mm)	3946	3946
	4.20	Length to face of forks (Standard Carriage)	l <sub>2</sub> (mm)	2946	2946
	4.20.1	Length to face of forks (Integrated Side Shift Carriage)	l <sub>2</sub> (mm)	2978	2978
	4.21	Overall width □	b <sub>1</sub> (mm)	1402 / 1485 / 1773	1402 / 1485 / 1773
	4.22	Fork dimensions ISO 2331	s/e/l (mm)	50 / 120 / 1000	50 / 120 / 1000
	4.23	Fork carriage ISO 2328, class/type A, B		IIIA	IIIA
	4.24	Fork carriage width (Standard Carriage) +	b <sub>3</sub> (mm)	1219	1219
	4.24.1	Fork carriage width (ISS Carriage) +	b <sub>3</sub> (mm)	1219	1219
	4.31	Ground clearance, laden, below mast	m <sub>1</sub> (mm)	151	151
	4.32	Ground clearance, centre of wheelbase	m <sub>2</sub> (mm)	194	194
	4.33	Load dimension b <sub>12</sub> x l <sub>6</sub> crossways	b <sub>12</sub> x l <sub>6</sub> (mm)	1200 x 1000	1200 x 1000
	4.34	Aisle width predetermined load dimensions ○	A <sub>st</sub> (mm)	4293	4293
	4.34.1	Aisle width with pallets 1000mm x 1200mm crossways ○	A <sub>st</sub> (mm)	3970	3970
	4.34.2	Aisle width with pallets 800mm wide x 1200mm lengthways ○	A <sub>st</sub> (mm)	3970	3970
	4.35	Turning radius	W <sub>3</sub> (mm)	2570	2570
	4.36	Internal turning radius	b <sub>13</sub> (mm)	751	751
	4.41	90° intersecting aisle (with pallet W = 1200mm, L = 1000mm)	(mm)	2298	2298
4.42	Step height (from ground to running board)	(mm)	801	801	
4.43	Step height (between intermediate steps between running board and floor)	(mm)	441	441	
Performance data	5.1	Travel speed laden/unladen	km/h	19.9 / 20.5	24.8 / 25.3
	5.1.1	Travel speed, laden/unladen, backwards	km/h	19.9 / 20.5	19.9 / 20.5
	5.2	Lift speed, laden/unladen	m/s	0.62 / 0.63	0.62 / 0.63
	5.3	Lowering speed, laden/unladen	m/s	0.55 / 0.47	0.55 / 0.47
	5.5	Drawbar pull, laden/unladen *	N	25629 / 15616	30689 / 15616
	5.7	Gradeability, laden/unladen **	N	26.9 / 27.2	32.7 / 27.2
	5.9	Acceleration time, laden/unladen ***	%	5.1 / 4.3	5.2 / 4.4
5.10	Service brake	s	Hydraulic	Hydraulic	
7.5	Fuel consumption according to VDI cycle	l/h or kg/h	4.3	4.4	
Addition data	8.1	Type of drive unit		Hydrodynamic	Hydrodynamic
	10.1	Operating pressure for attachments	bar	155	155
	10.2	Oil volume for attachments ◇	l/min	83.3	83.3
	10.3	Hydraulic oil tank, capacity	litres	51.0	51.0
	10.4	Fuel tank, capacity	litres	38.6	38.6
	10.7	Sound pressure level at the driver's seat ⇔ ★	dB(A)	79	79
	10.7.1	Sound power level during the workcycle ◆	dB(A)	99	99
	10.7.2	Guaranteed sound power 2000/14/EC	dB(A)	103	103
	10.8	Towing coupling, type DIN		Pin	Pin

▲ Top of forks.  
 ► Add 32mm with load backrest.  
 ✕ Full suspension seat in depressed position.  
 + W/o load backrest, add 32mm with load backrest.  
 □ Standard/Wide/Dual.

○ Stacking aisle width (lines 4.34 & 4.34.1 & 4.34.2) are based on the VDI standard calculation as shown on illustration. The British Industrial Truck Association recommends the addition of 100 mm to the total clearance (dimension a) for extra

operating margin at the rear of the truck.  
 \* at 1.6km/h.  
 \*\* at 4.8km/h. Gradeability figures are provided for comparison of tractive performance, but are not intended to endorse the operation of

the vehicle on the stated inclines. Follow instructions in the operating manual regarding operation on inclines.  
 \*\*\* to 15m (per VDI 2198 December 2012).

# Specifications (LPG)

Yale	Yale	Yale	Yale	Yale	Yale	1.1
GLP 40VX6			GLP 45SVX5			1.2
Kubota 3.8L Techtronix 100, 1-Speed	Kubota 3.8L Techtronix 200, 2-Speed	Kubota 3.8L Techtronix 200, 2-Speed	Kubota 3.8L Techtronix 100, 1-Speed	Kubota 3.8L Techtronix 200, 2-Speed	Kubota 3.8L Techtronix 200, 2-Speed	
Value	Value	Productivity	Value	Value	Productivity	
Standard or Premium Oil-immersed	Standard or Premium Oil-immersed	Premium Oil-immersed	Standard or Premium Oil-immersed	Standard or Premium Oil-immersed	Premium Oil-immersed	
LPG	LPG	LPG	LPG	LPG	LPG	1.3
Seated	Seated	Seated	Seated	Seated	Seated	1.4
4.0	4.0	4.0	4.5	4.5	4.5	1.5
600	600	600	500	500	500	1.6
523	523	523	591	591	591	1.8
555	555	555	608	608	608	1.8.1
1830	1830	1830	1830	1830	1830	1.9
6470	6470	6470	6826	6826	6826	2.1
9133 / 1337	9133 / 1337	9133 / 1337	10114 / 1212	10114 / 1212	10114 / 1212	2.2
2678 / 3792	2678 / 3792	2678 / 3792	2931 / 3895	2931 / 3895	2931 / 3895	2.3
SE	SE	SE	SE	SE	SE	3.1
250 x 15	250 x 15	250 x 15	250 x 15	250 x 15	250 x 15	3.2
700 x 12	700 x 12	700 x 12	700 x 12	700 x 12	700 x 12	3.3
2x / 2	2x / 2	2x / 2	2x / 2	2x / 2	2x / 2	3.5
1152	1152	1152	1152	1152	1152	3.6
1136	1136	1136	1136	1136	1136	3.7
6 / 10	6 / 10	6 / 10	6 / 10	6 / 10	6 / 10	4.1
2171	2171	2171	2215	2215	2215	4.2
100	100	100	100	100	100	4.3
3000	3000	3000	2740	2740	2740	4.4
3815	3815	3815	3730	3730	3730	4.5
2258	2258	2258	2258	2258	2258	4.7
1279	1279	1279	1279	1279	1279	4.8
429	429	429	429	429	429	4.12
3977	3977	3977	4266	4266	4266	4.19
2977	2977	2977	3066	3066	3066	4.20
3009	3009	3009	3083	3083	3083	4.20.1
1402 / 1485 / 1773	1402 / 1485 / 1773	1402 / 1485 / 1773	1402 / 1485 / 1773	1402 / 1485 / 1773	1402 / 1485 / 1773	4.21
50 / 120 / 1000	50 / 120 / 1000	50 / 120 / 1000	50 / 120 / 1000	50 / 120 / 1000	50 / 120 / 1000	4.22
IIIA	IIIA	IIIA	IVA	IVA	IVA	4.23
1219	1219	1219	1219	1219	1219	4.24
1219	1219	1219	1219	1219	1219	4.24.1
151	151	151	151	151	151	4.31
194	194	194	194	194	194	4.32
1200 x 1000	1200 x 1000	1200 x 1000	1200 x 1000	1200 x 1000	1200 x 1000	4.33
3799	3799	3799	3819	3819	3819	4.34
3999	3999	3999	4019	4019	4019	4.34.1
3999	3999	3999	4019	4019	4019	4.34.2
2599	2599	2599	2619	2619	2619	4.35
751	751	751	751	751	751	4.36
2314	2314	2314	2332	2332	2332	4.41
801	801	801	801	801	801	4.42
441	441	441	441	441	441	4.43
19.9 / 20.4	24.8 / 25.3	24.8 / 25.3	19.8 / 20.4	24.4 / 25.3	24.4 / 25.3	5.1
19.9 / 20.4	19.9 / 20.4	19.9 / 20.4	19.8 / 20.4	19.8 / 20.4	19.8 / 20.4	5.1.1
0.62 / 0.63	0.62 / 0.63	0.62 / 0.63	0.45 / 0.46	0.45 / 0.46	0.45 / 0.46	5.2
0.55 / 0.47	0.55 / 0.47	0.55 / 0.47	0.51 / 0.42	0.51 / 0.42	0.51 / 0.42	5.3
25589/15292	30649 / 15292	30649 / 15292	25421 / 16781	30481 / 16781	30481 / 16781	5.5
26.3/25.7	31.9 / 25.7	31.9 / 25.7	24.3 / 26.7	29.5 / 26.7	29.5 / 26.7	5.7
5.2 / 4.3	5.2 / 4.5	5.2 / 4.5	5.3 / 4.4	5.4 / 4.5	5.4 / 4.5	5.9
Hydraulic	Hydraulic	Hydraulic	Hydraulic	Hydraulic	Hydraulic	5.10
4.4	4.5	4.5	4.6	4.7	4.7	75
Hydrodynamic	Hydrodynamic	Hydrodynamic	Hydrodynamic	Hydrodynamic	Hydrodynamic	8.1
155	155	155	155	155	155	10.1
83.3	83.3	83.3	83.3	83.3	83.3	10.2
51.0	51.0	51.0	51.0	51.0	51.0	10.3
38.6	38.6	38.6	38.6	38.6	38.6	10.4
79	79	79	79	79	79	10.7
99	99	99	99	99	99	10.7.1
103	103	103	103	103	103	10.7.2
Pin	Pin	Pin	Pin	Pin	Pin	10.8

Distinguishing mark

Weights

Tyres/chassis

Dimensions

Performance data

Addition data

◇ Variable.  
 ⇒ With and without cab.  
 ★ Lpaz. Measured according to the test cycles and based on the weighting values contained in EN12053.

◆ LWAZ, measured according to the test cycles and based on the weighting values contained in EN12053.

Specification truck based on:  
 3050mm (GLP40VX5-GLP40VX6) / 2800mm (GLP45VX5 - GLP55VX) TOF 2 stage LFL mast with standard carriage, 1000mm (GLP40VX5) / 1200mm (GLP40VX6 - GLP55VX) forks with e-hydraulics.



# Specifications (LPG)

## VDI 2198 – General Specifications, LPG powered GLP 45VX6, GLP 50VX, GLP 55VX

			Yale	Yale	Yale		
Distinguishing mark	1.1	Manufacturer (abbreviation)					
	1.2	Manufacturer's type designation		GLP 45VX6			
		Engine/Transmission		Kubota 3.8L Techtronix 100, 1-Speed	Kubota 3.8L Techtronix 200, 2-Speed	Kubota 3.8L Techtronix 200, 2-Speed	
		Model		Value	Value	Productivity	
		Brake Type		Premium Oil-immersed	Premium Oil-immersed	Premium Oil-immersed	
	1.3	Drive: electric (battery or mains), diesel, petrol, fuel gas		LPG	LPG	LPG	
	1.4	Operator type: hand, pedestrian, standing, seated, orderpicker		Seated	Seated	Seated	
	1.5	Rated capacity / rated load	Q (t)	4.5	4.5	4.5	
	1.6	Load centre distance	c (mm)	600	600	600	
Weights	1.8	Load distance, centre of drive axle to fork	x (mm)	591	591	591	
	1.8.1	Load distance, centre of drive axle to fork (ISS Carriage)	x (mm)	608	608	608	
	1.9	Wheelbase	y (mm)	2100	2100	2100	
	2.1	Service weight	kg	7225	7225	7225	
	2.2	Axle loading, laden front / rear	kg	10323 / 1402	10323 / 1402	10323 / 1402	
	2.3	Axle loading, unladen front / rear	kg	3271 / 3954	3271 / 3954	3271 / 3954	
	Tyres/chassis	3.1	Tyres: P = pneumatic, V = cushion, SE = superelastic		SE	SE	SE
		3.2	Tyre size, front		300 x 15	300 x 15	300 x 15
		3.3	Tyre size, rear		28 x 9-15	28 x 9-15	28 x 9-15
3.5		Number of wheels, front/rear (x = driven wheels)		2x / 2	2x / 2	2x / 2	
3.6		Tread, front	b <sub>10</sub> (mm)	1150	1150	1150	
3.7		Tread, rear	b <sub>11</sub> (mm)	1162	1162	1162	
Dimensions		4.1	Tilt of mast/fork carriage, forward / backward	$\alpha / \beta$ (°)	6 / 10	6 / 10	6 / 10
	4.2	Height, mast lowered	h <sub>1</sub> (mm)	2215	2215	2215	
	4.3	Free lift ▲	h <sub>2</sub> (mm)	100	100	100	
	4.4	Lift ▲	h <sub>3</sub> (mm)	2740	2740	2740	
	4.5	Height, mast extended +	h <sub>4</sub> (mm)	3730	3730	3730	
	4.7	Height of overhead guard (cabin)	h <sub>6</sub> (mm)	2300	2300	2300	
	4.8	Seat height relating to SIP/stand height ✕	h <sub>7</sub> (mm)	1321	1321	1321	
	4.12	Coupling height	h <sub>10</sub> (mm)	429	429	429	
	4.19	Overall length	l <sub>1</sub> (mm)	4457	4457	4457	
	4.20	Length to face of forks (Standard Carriage)	l <sub>2</sub> (mm)	3257	3257	3257	
	4.20.1	Length to face of forks (Integrated Side Shift Carriage)	l <sub>2</sub> (mm)	3274	3274	3274	
	4.21	Overall width □	b <sub>1</sub> (mm)	1450 / 1575 / 1875	1450 / 1575 / 1875	1450 / 1575 / 1875	
	4.22	Fork dimensions ISO 2331	s/e/l (mm)	60 / 150 / 1200	60 / 150 / 1200	60 / 150 / 1200	
	4.23	Fork carriage ISO 2328, class/type A, B		IVA	IVA	IVA	
	4.24	Fork carriage width (Standard Carriage) +	b <sub>3</sub> (mm)	1219	1219	1219	
	4.24.1	Fork carriage width (ISS Carriage) +	b <sub>3</sub> (mm)	1372	1372	1372	
	4.31	Ground clearance, laden, below mast	m <sub>1</sub> (mm)	194	194	194	
	4.32	Ground clearance, centre of wheelbase	m <sub>2</sub> (mm)	237	237	237	
	4.33	Load dimension b <sub>12</sub> x l <sub>6</sub> crossways	b <sub>12</sub> x l <sub>6</sub> (mm)	1200 x 1000	1200 x 1000	1200 x 1000	
	Performance data	4.34	Aisle width predetermined load dimensions ○	A <sub>st</sub> (mm)	4037	4037	4037
4.34.1		Aisle width with pallets 1000mm x 1200mm crossways ○	A <sub>st</sub> (mm)	4237	4237	4237	
4.34.2		Aisle width with pallets 800mm wide x 1200mm lengthways ○	A <sub>st</sub> (mm)	4237	4237	4237	
4.35		Turning radius	W <sub>a</sub> (mm)	2837	2837	2837	
4.36		Internal turning radius	b <sub>13</sub> (mm)	800	800	800	
4.41		90° intersecting aisle (with pallet W = 1200mm, L = 1000mm)	(mm)	2447	2447	2447	
4.42		Step height (from ground to running board)	(mm)	844	844	844	
4.43		Step height (between intermediate steps between running board and floor)	(mm)	484	484	484	
5.1		Travel speed laden/unladen	km/h	18.7 / 19.2	23.3 / 23.9	23.3 / 23.9	
5.1.1		Travel speed, laden/unladen, backwards	km/h	18.7 / 19.2	18.7 / 19.2	18.7 / 19.2	
Addition data	5.2	Lift speed, laden/unladen	m/s	0.45 / 0.46	0.45 / 0.46	0.45 / 0.46	
	5.3	Lowering speed, laden/unladen	m/s	0.51 / 0.42	0.51 / 0.42	0.51 / 0.42	
	5.5	Drawbar pull, laden/unladen *	N	29632 / 18782	35405 / 18782	35405 / 18782	
	5.7	Gradeability, laden/unladen **	N	26 / 28.3	31.5 / 28.3	31.5 / 28.3	
	5.9	Acceleration time, laden/unladen ***	%	5.2 / 4.4	5.3 / 4.5	5.3 / 4.5	
	5.10	Service brake	s	Hydraulic	Hydraulic	Hydraulic	
	7.5	Fuel consumption according to VDI cycle	l/h or kg/h	4.9	5.0	5.0	
	8.1	Type of drive unit		Hydrodynamic	Hydrodynamic	Hydrodynamic	
Addition data	10.1	Operating pressure for attachments	bar	155	155	155	
	10.2	Oil volume for attachments ◇	l/min	83.3	83.3	83.3	
	10.3	Hydraulic oil tank, capacity	litres	678	678	678	
	10.4	Fuel tank, capacity	litres	38.6	38.6	38.6	
	10.7	Sound pressure level at the driver's seat ∞ ★	dB(A)	79	79	79	
	10.7.1	Sound power level during the workcycle ◆	dB(A)	99	99	99	
	10.7.2	Guaranteed sound power 2000/14/EC	dB(A)	103	103	103	
	10.8	Towing coupling, type DIN		Pin	Pin	Pin	

▲ Top of forks.

◆ Add 32mm with load backrest.

✕ Full suspension seat in depressed position.

□ W/o load backrest, add 32mm with load backrest.

□ Standard/Wide/Dual.

○ Stacking aisle width (lines 4.34 & 4.34.1 & 4.34.2) are based on the VDI standard calculation as shown on illustration. The British Industrial Truck Association recommends the addition of 100 mm to the total clearance (dimension a) for extra

operating margin at the rear of the truck.

\* at 1.6km/h.

\*\* at 4.8km/h. Gradeability figures are provided for comparison of tractive performance, but are not intended to endorse the operation of

the vehicle on the stated inclines. Follow instructions in the operating manual regarding operation on inclines.

\*\*\* to 15m (per VDI 2198 December 2012).

# Specifications (LPG)

Yale	Yale	Yale	Yale	Yale	Yale	1.1
	GLP 50VX			GLP 55VX		1.2
Kubota 3.8L Techtronix 100, 1-Speed	Kubota 3.8L Techtronix 200, 2-Speed	Kubota 3.8L Techtronix 200, 2-Speed	Kubota 3.8L Techtronix 100, 1-Speed	Kubota 3.8L Techtronix 200, 2-Speed	Kubota 3.8L Techtronix 200, 2-Speed	
Value	Value	Productivity	Value	Value	Productivity	
Premium Oil-immersed	Premium Oil-immersed	Premium Oil-immersed	Premium Oil-immersed	Premium Oil-immersed	Premium Oil-immersed	
LPG	LPG	LPG	LPG	LPG	LPG	1.3
Seated	Seated	Seated	Seated	Seated	Seated	1.4
5.0	5.0	5.0	5.5	5.5	5.5	1.5
600	600	600	600	600	600	1.6
591	591	591	591	591	591	1.8
608	608	608	608	608	608	1.8.1
2100	2100	2100	2100	2100	2100	1.9
7520	7520	7520	7811	7811	7811	2.1
11041 / 1478	11041 / 1478	11041 / 1478	11754 / 1558	11754 / 1558	11754 / 1558	2.2
3206 / 4314	3206 / 4314	3206 / 4314	3134 / 4677	3134 / 4677	3134 / 4677	2.3
SE	SE	SE	SE	SE	SE	3.1
300x15	300 x 15	300 x 15	300 x 15	300 x 15	300 x 15	3.2
28x9-15	28 x 9-15	28 x 9-15	28 x 9-15	28 x 9-15	28 x 9-15	3.3
2x / 2	2x / 2	2x / 2	2x / 2	2x / 2	2x / 2	3.5
1150	1150	1150	1150	1150	1150	3.6
1162	1162	1162	1162	1162	1162	3.7
6 / 10	6 / 10	6 / 10	6 / 10	6 / 10	6 / 10	4.1
2215	2215	2215	2215	2215	2215	4.2
100	100	100	100	100	100	4.3
2740	2740	2740	2740	2740	2740	4.4
3730	3730	3730	3730	3730	3730	4.5
2300	2300	2300	2300	2300	2300	4.7
1321	1321	1321	1321	1321	1321	4.8
429	429	429	429	429	429	4.12
4500	4500	4500	4541	4541	4541	4.19
3300	3300	3300	3341	3341	3341	4.20
3317	3317	3317	3358	3358	3358	4.20.1
1450 / 1575 / 1875	1450 / 1575 / 1875	1450 / 1575 / 1875	1450 / 1575 / 1875	1450 / 1575 / 1875	1450 / 1575 / 1875	4.21
60 / 150 / 1200	60 / 150 / 1200	60 / 150 / 1200	60 / 150 / 1200	60 / 150 / 1200	60 / 150 / 1200	4.22
IVA	IVA	IVA	IVA	IVA	IVA	4.23
1219	1219	1219	1219	1219	1219	4.24
1372	1372	1372	1372	1372	1372	4.24.1
194	194	194	194	194	194	4.31
237	237	237	237	237	237	4.32
1200 x 1000	1200 x 1000	1200 x 1000	1200 x 1000	1200 x 1000	1200 x 1000	4.33
4077	4077	4077	4115	4115	4115	4.34
4277	4277	4277	4315	4315	4315	4.34.1
4277	4277	4277	4315	4315	4315	4.34.2
2877	2877	2877	2915	2915	2915	4.35
800	800	800	800	800	800	4.36
2469	2469	2469	2490	2490	2490	4.41
844	844	844	844	844	844	4.42
484	484	484	484	484	484	4.43
18.7 / 19.2	23.2 / 23.9	23.2 / 23.9	18.6 / 19.2	23.0 / 23.9	23.0 / 23.9	5.1
18.7 / 19.2	18.7 / 19.2	18.7 / 19.2	18.6 / 19.2	18.6 / 19.2	18.6 / 19.2	5.1.1
0.45 / 0.46	0.45 / 0.46	0.45 / 0.46	0.45 / 0.46	0.45 / 0.46	0.45 / 0.46	5.2
0.51 / 0.42	0.51 / 0.42	0.51 / 0.42	0.51 / 0.42	0.51 / 0.42	0.51 / 0.42	5.3
29575 / 18399	35348 / 18399	35348 / 18399	29419 / 17976	35192 / 17976	35192 / 17976	5.5
25.2 / 26.5	30.6 / 26.5	30.6 / 26.5	23.5 / 24.8	28.5 / 24.8	28.5 / 24.8	5.7
5.3 / 4.4	5.3 / 4.5	5.3 / 4.5	5.4 / 4.4	5.5 / 4.5	5.5 / 4.5	5.9
Hydraulic	Hydraulic	Hydraulic	Hydraulic	Hydraulic	Hydraulic	5.10
5.0	5.1	5.1	5.2	5.3	5.3	75
Hydrodynamic	Hydrodynamic	Hydrodynamic	Hydrodynamic	Hydrodynamic	Hydrodynamic	8.1
155	155	155	155	155	155	10.1
83.3	83.3	83.3	83.3	83.3	83.3	10.2
678	678	678	678	678	678	10.3
38.6	38.6	38.6	38.6	38.6	38.6	10.4
79	79	79	79	79	79	10.7
99	99	99	99	99	99	10.7.1
103	103	103	103	103	103	10.7.2
Pin	Pin	Pin	Pin	Pin	Pin	10.8

Distinguishing mark

Weights

Tyres/chassis

Dimensions

Performance data

Addition data

◇ Variable.  
 ⇒ With and without cab.  
 ★ Lpaz. Measured according to the test cycles and based on the weighting values contained in EN12053.

◆ LWAZ, measured according to the test cycles and based on the weighting values contained in EN12053.

Specification truck based on:  
 3050mm (GLP40VX5-GLP40VX6) / 2800mm (GLP455 VX5 - GLP55VX) TOF 2 stage LFL mast with standard carriage, 1000mm (GLP40VX5) / 1200mm (GLP40VX6 - GLP55VX) forks with e-hydraulics.

# Yale GDP40-55VX

This series of trucks is available in three configurations:-

**The Veracitor Base** truck offers first rate performance across a wide range of applications, geared to minimise cost of acquisition without compromising performance.

**The Veracitor Value** truck provides excellent performance for standard and medium-duty applications, optimised for lowest hourly operation cost.

## Diesel Engines

Yale VX40-55 Base and Value models feature the Kubota V3600 4-cylinder IDI-T mechanically/electronically controlled turbocharged diesel engine with 57kW. These engines are compatible with category 1 diesel fuel which contains sulphur levels of over 500ppm. Engine rpm, coolant temperature and oil pressure are monitored by the VSM.

## Transmission

Three transmission selections are available with multiple engine configurations for a wide variety of material handling applications.

Yale VX40-55 Base model is available with a Standard Electronic Powershift transmission only, featuring either one or two speeds. Yale VX40-55 Value model is available with a Techtronix 100 (1 speed) or a Techtronix 200 (2 speed) transmission.

**Standard Electronic Powershift** available with one speed or two speed forward/one speed reverse and Cowl Mounted Mechanical Levers.

**The Techtronix 100** transmission is available with one speed forward/one speed reverse. Features electronic inching, Auto Deceleration System (ADS) through the controlled application of clutch packs to slow the truck down without the need to apply the foot brake. Controlled Power Reversal (CPR) reduces tyre spin by precisely regulating engine speed during full power reversal situations and Controlled Roll-Back (CRB) limits rollback on gradients to 75mm per second.

**The Techtronix 200** available with two speed forward/one speed reverse, has all the Techtronix features, plus Two Speed Auto Shift (2 x forward, 1 x reverse).

## Cooling System

The cooling system employs a 43cm blade pusher-type fan. A permanently lubricated water pump and a high capacity, cross-flow radiator ensures rapid heat dissipation. The sealed cooling system operates at 15 psi, the coolant recovery tank allows visual inspection of coolant level. The combi-cooler radiator features an externally mounted transmission oil cooler for increased heat transfer capability. All radiators are soft mounted for durability.

## Drive Axle

The drive axle is designed to withstand heavy-duty applications and absorb shock loads. It is a "self-contained" assembly isolated from the transmission by a heavy-duty rubber isolator. The axle shafts utilise a "rolled fillet" root spline design for increased resistance to torsion stress.

A magnetic sump plug collects any metal particles circulating in the axle oil to prevent component wear.

## Hydraulic Power Steering

Hydrostatic steering provides responsive control and eliminates mechanical linkages for reduced surface shock and simplified maintenance. The steering wheel is 30cm in diameter with a textured surface grip and spinner knob, and requires only four turns lock-to-lock. The centre mounted steer cylinder is located within the confines of the steer axle for protection.

## Steer Axle

Constructed from cast steel, the steer axle is rubber shock mounted to the frame for reduced wear and vibration. The CSE (Continuous Stability Enhancement) system enhances lateral truck stability through reduced steer axle articulation, while simultaneously allowing uncompromised uneven surface travel.

## Operator's Compartment

All trucks are available with a new mini-lever armrest, which features a new contoured design, and - in addition to the hydraulic functions -

features a horn and direction switch, ensuring that all key truck functions are within constant, easy reach. The Full Suspension Seat together with the isolated powertrain provide best in class Whole-Body Vibration levels of 0.6m/s<sup>2</sup>, ensuring that the operator remains comfortable throughout the shift and fatigue, aches and pains are kept to a minimum. Automotive-style pedal arrangement with a large, single inch/brake pedal is standard.

A full range of cabs including heating and air conditioning are available.

## Intellix Vehicle System Management (VSM)

VSM acts as a master truck controller, providing extensive monitoring and control of truck functions and systems. CANbus technology reduces wiring complexity and enables communications between truck systems. The dash display transmits continual feedback to the operator and allows communication of service codes. On-board diagnostics enable quick and easy troubleshooting. The electrical system features sealed connectors and Hall Effect sensors for superior dependability.

## Hydraulic System

The hydraulic system incorporates a low noise gear type pump with cast iron body or for trucks fitted with Load Sense Hydraulics (with AccuTouch™ levers) a variable displacement piston pump delivering oil flow on demand. The system is protected from overloads by a main relief valve for the lift circuit and secondary relief valve for tilt and auxiliary functions. Oil is double filtered through a 100 mesh suction line strainer and 10 micron return line filter. The hydraulic tank is integrated into the frame.

For AccuTouch™ electro-hydraulic controls, an emergency lowering valve is provided to allow the load to be lowered in the event of power loss. O-ring face seal fittings are used in all high pressure hydraulic connections.

# Yale GLP40-55VX

This series of trucks is available in three configurations:-

**The Veracitor Value** truck provides excellent performance for standard and medium-duty applications, optimised for lowest hourly operation cost.

**The Veracitor Productivity** truck delivers maximum performance for medium to heavy-duty applications with state-of-the-art features and industry leading power.

## LPG Engines

Yale Veracitor VX, features the new Kubota WG3800 LPG spark ignition engine delivering 64kW@2,200 or 54kW@1,800, with a combustion chamber, fuel and ignition system dedicated for LPG. The LPG Engine is derived from the diesel version and shares many of its operational characteristics that make it an ideal match for use in forklift trucks (high levels of torque at low rpm, low max rated speed, low noise and heavy duty robust construction).

## Load Sensing Hydraulics (LSH)

LSH is standard on trucks with AccuTouch™ mini levers, delivering increased operational efficiency, offering a 15% reduction in fuel consumption on the VDI cycle, with no loss in productivity\*. Variable displacement hydraulic piston pump matches the oil flow rate continuously to the lifting speed and the demands of the duty cycle. The engine therefore supplies only power to the hydraulic pumps when required, so more power is available for driving. This increases responsiveness and acceleration, which increases productivity and lowers fuel consumption, reducing overall operating costs.

With LSH Yale also offers an ECO-eLo (Fuel Efficiency) mode on many models. For LPG versions this is achieved by allowing full engine speed at lower torque outputs and optimising the throttle response, so that the truck operates in the most economical power range. This results in a reduction in fuel consumption of a further 5%\*, but has a limited effect on overall truck productivity in the operational environment. The ECO-eLo mode also delivers lower noise levels by up to 3dB(A). If a faster work rate, or higher productivity is required, the truck can easily be reprogrammed to HiP (High Performance) mode of

operation through the dash display, with access secured by a unique customer password.

*(\*Yale Productivity Test Cycle: Load Sensing Hydraulics and ECO-eLo functions are available on trucks with AccuTouch™ mini-levers and Techtronix™ transmissions only).*

## Transmission

Two transmission selections are available with multiple engine configurations for a wide variety of material handling applications. A single pedal controls both inching and braking.

**The Techtronix 100** features electronic inching, Auto Deceleration System (ADS) through the controlled application of clutch packs to slow the truck down without the need to apply the foot brake. Controlled Power Reversal (CPR) reduces tyre spin by precisely regulating engine speed during full power reversal situations and Controlled Roll-Back (CRB) limits roll-back on gradients to 75mm per second.

**The Techtronix 200** has all the Techtronix 100 features, plus Two Speed Auto Shift (2 x forward, 1 x reverse).

The Techtronix transmissions are available with Auto-speed Hydraulics which automatically increases engine speed on activation of the hydraulics, eliminating the need for inching when lifting the load.

## Cooling System

The cooling system employs a 43cm blade pusher-type fan. A permanently lubricated water pump and a high capacity, cross-flow radiator ensures rapid heat dissipation. The sealed cooling system operates at 15 psi, the coolant recovery tank allows visual inspection of coolant level. The combi-cooler radiator features an externally mounted transmission oil cooler for increased heat transfer capability. All radiators are soft mounted for durability.

## Drive Axle

The drive axle is designed to withstand heavy-duty applications and absorb shock loads. It is a "self-contained" assembly isolated

from the transmission by a heavy-duty rubber isolator. The axle shafts utilise a "rolled fillet" root spline design for increased resistance to torsion stress. A magnetic sump plug collects any metal particles circulating in the axle oil to prevent component wear.

## Brakes

The Standard oil-immersed brake axle is a self-contained unit with its own oil supply, whereas the Premium oil-immersed brake axle features an additional oil supply routed through the Combi-Cooler. The Premium oil-immersed brake axle should be specified into multiple shift operations, or where the brakes are in constant use. The Standard oil-immersed brake axle is not available on long wheelbase models.

## Hydraulic Power Steering

Hydrostatic steering provides responsive control and eliminates mechanical linkages for reduced surface shock and simplified maintenance. The steering wheel is 30cm in diameter with a textured surface grip and spinner knob, and requires only four turns lock-to-lock. The centre mounted steer cylinder is located within the confines of the steer axle for protection.

## Steer Axle

Constructed from cast steel, the steer axle is rubber shock mounted to the frame for reduced wear and vibration.

## Continuous Stability Enhancement (CSE)

The CSE system enhances lateral truck stability through reduced steer axle articulation, while simultaneously allowing uncompromised uneven surface travel.



## Branches

### VICTORIA

#### Melbourne – Springvale (Head Office)

📍 1574 Centre Rd  
Springvale, VIC, 3171  
☎ [03] 9547 8000

#### Melbourne – Truganina

📍 42–44 Jessica Way  
Truganina, VIC, 3029  
☎ [03] 9394 4090

### NEW SOUTH WALES

#### Sydney (State Office)

📍 219 Newton Rd  
Wetherill Park, NSW, 2164  
☎ [02] 8788 1777

#### Port Kembla

📍 20–26 Flinders Street  
Port Kembla, NSW, 2505  
☎ 13 22 54

### QUEENSLAND

#### Brisbane (State Office)

📍 11 Lombank Street  
Acacia Ridge, QLD, 4110  
☎ [07] 3373 5111

#### Rockhampton

📍 62 Glenmore Road  
Park Avenue, Rockhampton  
QLD 4701  
☎ [07] 4922 8874

#### Townsville

📍 39 Duckworth Street  
Garbutt, QLD, 4814  
☎ [07] 4778 2000

### SOUTH AUSTRALIA/ NORTHERN TERRITORY

#### Adelaide (State Office)

📍 18–22 Churchill Rd. Nth.  
Dry Creek, SA, 5094  
☎ [08] 8360 3444

### WESTERN AUSTRALIA

#### Perth (State Office)

📍 Unit 1, 1–9 Kurnall Road  
Welshpool, WA, 6106  
☎ [08] 9352 9200

#### Karratha

📍 Lot 3873–Pemberton Road  
Karratha, WA, 6714  
☎ 13 22 54

### TASMANIA

#### Spreyton

📍 87a Devonport Road  
Spreyton, TAS, 7310  
☎ [03] 6427 3966

## Service Centres

### VICTORIA

Bendigo  
Warrnambool  
Ballarat  
Shepparton  
Wondonga  
Mildura

### TASMANIA

Hobart  
Launceston  
Burnie

### NEW SOUTH WALES

Dubbo  
Griffith  
Tamworth  
Newcastle  
Wollongong  
Canberra  
Tumut  
Bathurst  
Wagga Wagga  
Albury  
Gosford  
Coffs Harbour

### QUEENSLAND

Rockhampton  
Mackay  
Cairns  
Gladstone  
Townsville  
Mt Isa  
Toowoomba  
Gold Coast  
Sunshine Coast

### SOUTH AUSTRALIA/NT

Riverland  
Darwin

### WESTERN AUSTRALIA

Margaret River



# 13 23 20

[www.adaptalift.com.au](http://www.adaptalift.com.au)